



Designation: D4367 – 22

Standard Test Method for Benzene in Hydrocarbon Solvents by Gas Chromatography¹

This standard is issued under the fixed designation D4367; the number immediately following the designation indicates the year of original adoption or, in the case of revision, the year of last revision. A number in parentheses indicates the year of last reapproval. A superscript epsilon (ϵ) indicates an editorial change since the last revision or reapproval.

1. Scope

1.1 This test method covers the determination by gas chromatography of benzene at levels from 0.01 to 1 volume % in hydrocarbon solvents.

NOTE 1—For benzene levels lower than 0.01 volume %, use Test Method D6229.

1.2 The values stated in SI units are to be regarded as the standard. The values given in parentheses are for information only.

1.3 For purposes of determining conformance of an observed or a calculated value using this test method to relevant specifications, test result(s) shall be rounded off “to the nearest unit” in the last right-hand digit used in expressing the specification limit, in accordance with the rounding-off method of Practice E29.

1.4 For hazard information and guidance, see the supplier’s Material Safety Data Sheet. For specific hazard statements, see Section 7.

1.5 *This standard does not purport to address all of the safety concerns, if any, associated with its use. It is the responsibility of the user of this standard to establish appropriate safety, health, and environmental practices and determine the applicability of regulatory limitations prior to use.*

1.6 *This international standard was developed in accordance with internationally recognized principles on standardization established in the Decision on Principles for the Development of International Standards, Guides and Recommendations issued by the World Trade Organization Technical Barriers to Trade (TBT) Committee.*

2. Referenced Documents

2.1 ASTM Standards:²

¹ This test method is under the jurisdiction of ASTM Committee D01 on Paint and Related Coatings, Materials, and Applications and is the direct responsibility of Subcommittee D01.35 on Solvents, Plasticizers, and Chemical Intermediates.

Current edition approved Jan. 1, 2022. Published January 2022. Originally approved in 1984. Last previous edition approved in 2012 as D4367 – 02 (2012) which was withdrawn January 2021 and reinstated in January 2022. DOI: 10.1520/D4367-22.

² For referenced ASTM standards, visit the ASTM website, www.astm.org, or contact ASTM Customer Service at service@astm.org. For *Annual Book of ASTM Standards* volume information, refer to the standard’s Document Summary page on the ASTM website.

D6229 Test Method for Trace Benzene in Hydrocarbon Solvents by Capillary Gas Chromatography
E29 Practice for Using Significant Digits in Test Data to Determine Conformance with Specifications
E300 Practice for Sampling Industrial Chemicals

3. Summary of Test Method

3.1 An internal standard, methyl ethyl ketone (MEK), is added to the material and then introduced into a gas chromatograph equipped with two columns connected in series. The specimen passes first through a column packed with the nonpolar phase, methyl silicone, which separates the components by boiling point. After octane has eluted, the flow through the nonpolar column is reversed, flushing out the components heavier than octane. The octane and lighter components then pass through a column with the highly polar phase, 1,2,3-tris(2-cyanoethoxy)propane, that separates the aromatic and nonaromatic compounds. The eluted components are detected by a conventional detector and recorded on a strip chart. The peak areas are measured and the concentration of each component is calculated by reference to the internal standard.

4. Significance and Use

4.1 Benzene is classed as a toxic and carcinogenic material. A knowledge of the concentration of this compound may be an aid in evaluating the possible health hazards to persons handling and using hydrocarbon solvents, but this test method is not intended to evaluate such hazards.

5. Apparatus

5.1 *Chromatograph*—Any gas chromatographic instrument that has a backflush system and flame ionization detector and that can be operated at the conditions given in Table 1. The detector-recorder combination must produce a 4-mm deflection for a 1- μ L specimen containing 0.05 volume % MEK when operated at maximum sensitivity.

5.2 *Columns*, one 0.8-m (2.5-ft) length of 3.2-mm ($\frac{1}{8}$ -in.) outside diameter stainless steel tubing and one 4.6-m (15-ft) length of 3.2-mm ($\frac{1}{8}$ -in.) outside diameter stainless steel tubing.

5.3 *Recorder, Strip Chart*—Potentiometer with a full-scale deflection of 1 mV, a full-scale response time of 2 s or less, and a maximum noise level of ± 0.3 % of full scale.

TABLE 1 Instrument Conditions Found Satisfactory for Measuring Low Concentrations of Benzene in Hydrocarbon Solvents (Note 2)

Detector	flame ionization
Columns	two, stainless steel
Length, m	(A) 0.8; (B) 4.6
Outside diameter, mm	3.2
Stationary phases	(A) methyl silicone, 10 weight % (B) TCEP, 25 weight %
Support	(A) acid-washed calcined diatomite, 60 to 80-mesh (B) acid-washed pink diatomaceous earth, 80 to 100-mesh
Reference column	any column or restriction may be used
Temperature, °C	
Injection port	150
Column, isothermal	100
Detector block	150
Carrier gas	helium
Flow rate, mL/min	approximately 30
Recorder range, mV	0 to 1
Chart speed, mm/min	10
Specimen size, μ L	1.0
Time to backflush, min	approximately 2
Total cycle time, min	approximately 30

5.4 *Microsyringe*, 5- μ L capacity.

5.5 *Pipets*, measuring 1 and 2 mL, graduated in 0.01 mL; 5, 10, and 20-mL capacity.

5.6 *Flasks*, volumetric, 25 and 100-mL capacity.

5.7 *Vibrator*, electric.

5.8 *Vacuum Source*.

5.9 *Evaporator*, vacuum, rotary.

5.10 *Flask*, boiling, round-bottom, short-neck, with 24/40 T joint, 500-mL capacity. Suitable for use with the evaporator (see 5.9).

5.11 *Lamp*, infrared.

5.12 *Burets*, automatic, with integral reservoir, 25-mL capacity.

NOTE 2—Suppliers of stationary phases and supports can be found in Research Report RR:D01-1038, available from ASTM International Headquarters.

6. Reagents and Materials

6.1 *Purity of Reagents*—Reagent grade chemicals shall be used in all tests. Unless otherwise indicated, it is intended that all reagents shall conform to the specifications of the Committee on Analytical Reagents of the American Chemical Society, where such specifications are available.³ Other grades may be used, provided it is first ascertained that the reagent is of sufficiently high purity to permit its use without lessening the accuracy of the determination.

6.2 *Acetone*.

³ ACS Reagent Chemicals, Specifications and Procedures for Reagents and Standard-Grade Reference Materials, American Chemical Society, Washington, DC. For suggestions on the testing of reagents not listed by the American Chemical Society, see *Analar Standards for Laboratory Chemicals*, BDH Ltd., Poole, Dorset, U.K., and the *United States Pharmacopeia and National Formulary*, U.S. Pharmacopeial Convention, Inc. (USPC), Rockville, MD.

6.3 *Chloroform*.

6.4 *Diatomaceous Earth*⁴—Acid-washed, 60 to 80 mesh and 80 to 100 mesh.

6.5 *Helium*, 99.99 % pure.

6.6 *Methanol*.

6.7 *Methylene Chloride*.

6.8 *Methyl Ethyl Ketone (MEK)*, 99.9 mol %.

6.9 *Methyl Silicone*.⁴

6.10 *1,2,3-Tris(2-Cyanoethoxy) Propane (TCEP)*.⁴

6.11 *Calibration Standards*.

6.11.1 *Benzene*, 99⁺ mol %.

6.11.2 *Isooctane*, 99⁺ mol %.

6.11.3 *n-Nonane*, 99⁺ mol %.

7. Hazards

7.1 Many hydrocarbon solvents are flammable and hazardous; use special precautions when handling them. Of the reagents used in this procedure, methanol, chloroform, methylene chloride, acetone, methyl ethyl ketone, benzene (see 4.1), and *n*-nonane are hazardous.

7.2 Benzene is volatile and highly flammable. Exercise care to prevent accidental ignition. Benzene is also carcinogenic and toxic; acute or chronic poisoning may result from inhalation of benzene vapor, absorption of benzene through the skin, or drinking benzene.

8. Sampling

8.1 Take samples of solvents to be analyzed by this test method using the procedures described in Practice E300.

9. Preparation of Columns

9.1 *Column Packing Preparation*—Prepare the two packing materials, one containing 10 % methyl silicone and the other 25 % TCEP, as follows:

9.1.1 Weigh 45 g of the acid-washed calcined diatomite support 60 to 80 mesh, into a 500-mL flask (see 5.10). Dissolve 5 g of the methyl silicone in approximately 50 mL of chloroform. (**Warning**—Chloroform is a toxic material and inhalation must be avoided.) Pour the methyl silicone–chloroform solution into the flask containing the support. Attach the flask to the evaporator (see 5.9), connect the vacuum, and start the motor. Turn on the infrared lamp and allow the packing to mix thoroughly until dry.

9.1.2 Weigh 75 g of acid-washed pink diatomaceous earth, 80 to 100 mesh, into a 500-mL flask (see 5.10). Dissolve 25 g of TCEP in 200 mL of methanol and pour into the flask containing the support. Attach the flask to the evaporator (see 5.9), connect the vacuum, and start the motor. Turn on the infrared lamp and allow the packing to mix thoroughly until dry, but do not heat the packing above 180 °C.

9.2 *Column Preparation*:

⁴ See Note 2.

9.2.1 Clean the stainless steel tubing as follows: Attach a metal funnel to one end of the steel tubing. Hold or mount the stainless steel tubing in an upright position and place a beaker under the outlet end of the tubing. Pour about 50 mL of methylene chloride into the funnel and allow it to drain through the steel tubing into the beaker. Repeat the washing with 50 mL of acetone. Remove the funnel and connect the steel tubing to an air line, by means of vinyl tubing. Remove all solvent from the steel tubing by blowing filtered, oil-free air through or applying a vacuum.

9.2.2 Pack the 0.8-m (2.5-ft) tubing (Column A) with the methyl silicone packing (see 9.1.1) and the 4.6-m (15-ft) tubing (Column B) with the TCEP packing (see 9.1.2) as follows: Preform Columns A and B separately to fit the chromatographic instrument. Close one end of each tubing with a small, glass wool plug and connect this end to a vacuum source by means of a glass-wool packed tube. To the other end connect a small polyethylene funnel by means of a short length of vinyl tubing. Start the vacuum and pour the appropriate packing into the funnel until the column is full. While filling each column, vibrate the column with the electric vibrator to settle the packing. Remove the funnel and shut off the vacuum source. Remove the top 6 mm (¼ in.) of packing and insert a glass wool plug in this end of the column.

9.3 Prepacked columns conforming to specifications listed in Table 1, and in 5.2, 9.1, and 9.2 may be obtained from any reputable chromatography supply company.

10. Preparation of Chromatographic Apparatus and Establishment of Conditions

10.1 Column Conditioning—Join Columns A and B as shown in Fig. 1. Connect the inlet of Column A to the injection port of the chromatograph. Pass helium gas through the column

at approximately 40 mL/min. Condition the columns in accordance with the following time-temperature schedule.

Temperature, °C	Time, h
50	½
100	½
150	1
170	3

10.2 Connect the outlet of Column B to the detector port. Adjust the operating conditions to those listed in Table 1, but do not turn on the detector circuits. Check the system for leaks.

10.3 Adjust the flow rate as follows:

10.3.1 Set the value in the forward flow mode (Fig. 2(a)) and adjust Flow Controller A to give the required flow rate (Table 1). Measure the flow rate at the detector vent, specimen side.

10.3.2 Set the valve in the backflush position (Fig. 2(b)) and measure the flow rate at the detector vent, specimen side. If the rate has changed, adjust Flow Controller B to obtain the required flow rate to within ±1 mL/min.

10.3.3 Turn on the detector circuit. Change the valve from forward flow to the backflush position several times and observe the baseline. There should be no baseline shift or drift after the initial peak resulting from the pressure surge with the valve change. If there is a baseline shift, slightly increase or decrease flow with Controller B to balance the baseline. (A persistent drift indicates leaks somewhere in the system.)

10.4 Determine time before backflushing, which varies for each column system and must be determined experimentally as follows:

10.4.1 Prepare a mixture of 5 volume % isooctane in n-nonane. Using the injection technique described in 11.3 and with the system in the forward flow mode, inject 1 µL of the isooctane-n-nonane mixture. Allow the chromatogram to run until the n-nonane has eluted and the recorder pen has returned to baseline. Measure the time in seconds from the injection until the recorder pen returns to baseline between the isooctane

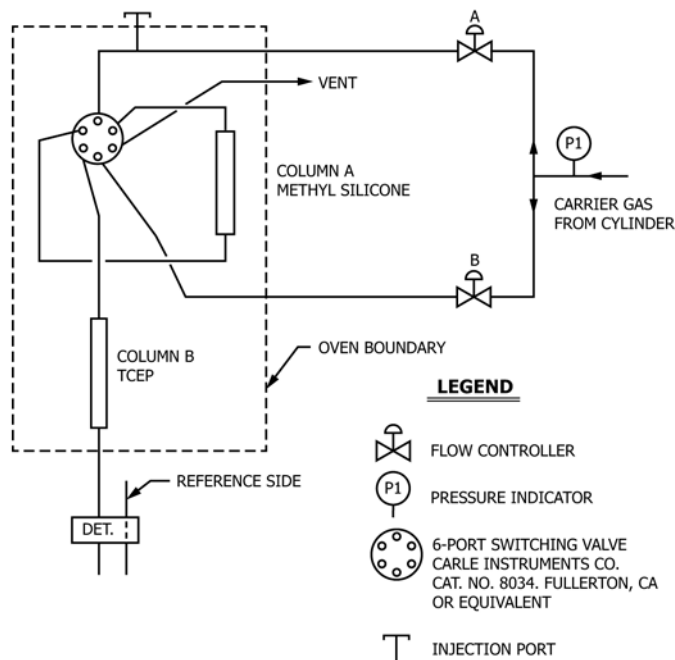

FIG. 1 Tubing Assembly and Instrumentation

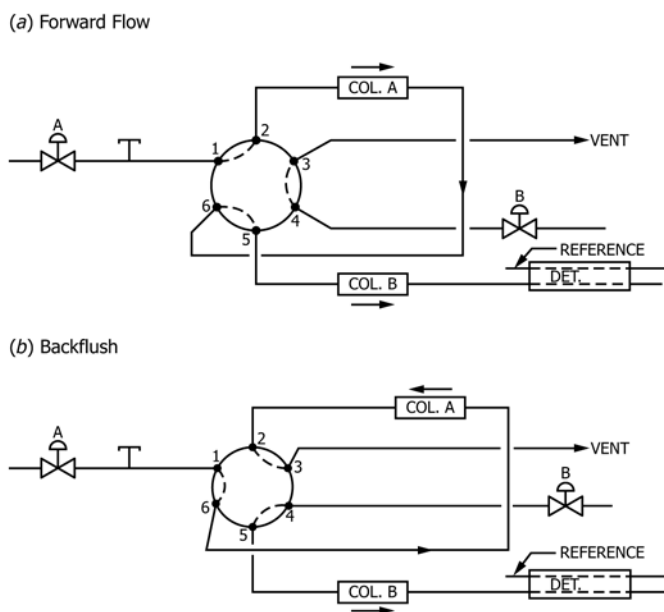

FIG. 2 Flow Switching System

and *n*-nonane peaks. At this point all of the *isooctane* but essentially none of the *n*-nonane should have eluted. One half of the measured time approximates the time to backflush and should be from 30 to 120 s.

10.4.2 Repeat the run, including the injection, but switching the system to the *backflush* mode at the determined backflush time. This should result in a chromatogram of *isooctane* with little or no *n*-nonane evident.

10.4.3 If necessary, make additional runs, adjusting the time to backflush until a chromatogram of all the *isooctane* and little or none of the *n*-nonane is obtained. This established backflush time, including the *actual valve operations*, must be used in all subsequent calibrations and analyses.

11. Calibration and Standardization

11.1 *Standard Solutions*—Prepare seven standard solutions covering the range of 0 to 1 volume % benzene as follows: For each standard, measure the volume of benzene listed below into a 100-mL volumetric flask. Dilute to volume with *isooctane*, with all components and glassware at normal room temperature, and mix thoroughly.

Volume %	Benzene	mL
1		1
0.5		0.5
0.25		0.25
0.10		0.10
0.05		0.05
0.01		0.01
0.005		0.005

11.2 *Calibration Solutions*—Accurately measure 0.5 mL of MEK into a 100-mL volumetric flask, fill to the mark with the first standard solution (see 11.1), and mix thoroughly. Repeat with each of the other standard solutions.

11.3 *Chromatographic Analysis*—Using the conditions established in 10.3 and 10.4, chromatograph each of the calibration solutions after injecting them as follows: Flush the 5- μ L microsyringe at least three times with the calibration solution and then fill with about 3 μ L, avoiding inclusion of air bubbles in the syringe. Slowly eject the material until 1.0 μ L remains in the syringe. Wipe the needle with a tissue and draw back the plunger to admit 1 μ L of air into the syringe. Insert the needle of the syringe into the septum cap of the chromatograph and push through the septum until the barrel of the syringe is resting against the septum cap; then rapidly push the plunger to the hilt and immediately withdraw the needle from the injection port.

NOTE 3—This injection technique is necessary to obtain sharp symmetrical peaks.

11.4 *Calibration*—Measure the areas of the benzene and of MEK peaks by conventional means (Note 4). Calculate the ratio of the benzene peak area to the MEK peak area. Plot the concentration of benzene versus the ratio as in Fig. 3. The calibration must be done to ensure that the entire chromatographic system is operating properly and that the concentration of any one component has not exceeded the linear response

range of any part of the system—column, detector, integrator, and other components. The calibration plot should be linear (Note 5). Determine the retention times for each component for future identification.

NOTE 4—The precision statement in Section 15 was developed from results obtained using electronic integrators or on-line computers. The precision statement may not apply if other methods of integration or peak area measurement are used.

NOTE 5—If the calibration is linear, a least-squares calculation may be performed to obtain a calibration factor. The precision statement in Section 15 was developed from results obtained from calibration plots and may not apply if calibration factors are used.

12. Procedure

12.1 *Test Solution*—Accurately measure 0.5 mL of MEK into a 100-mL volumetric flask. Fill to the mark with the material under test and mix well.

12.2 Chromatograph a specimen from the test solution using the conditions established in 10.3 and 10.4 and the injection technique described in 11.3.

NOTE 6—The valves must be turned to the *backflush* mode at the established backflush time so that undesirable components do not enter Column B.

12.3 Identify on the chromatogram the benzene and the internal standard MEK peaks from the retention times of the standards.

NOTE 7—The order of elution is nonaromatic hydrocarbons, benzene, MEK, and toluene when using the specified columns, as shown in Fig. 4.

12.4 Measure the areas under the benzene peak and under the MEK peak by conventional methods.

13. Calculation

13.1 Calculate the ratio of peak area of benzene to the peak area of MEK. Read from the calibration curve the volume % of benzene corresponding to the calculated peak ratio.

13.2 If the results are desired on a weight basis, convert to weight % as follows:

$$\text{Benzene, weight \%} = (V/D) \times 0.8844 \quad (1)$$

where:

V = benzene, volume %, and

D = relative density of sample at 15.6/15.6 °C (60/60 °F).

14. Report

14.1 Report the following information: benzene content in volume or weight % to the nearest 0.005 %.

15. Precision and Bias⁵

15.1 *Precision*—The precision statements are based on an interlaboratory study in which analysts in each of six laboratories analyzed seven hydrocarbon solvent samples, including

⁵ Supporting data have been filed at ASTM International Headquarters and may be obtained by requesting Research Report RR:D01-1038. Contact ASTM Customer Service at service@astm.org.