



Designation: **D6710–17** **D6710 – 21**

Standard Guide for Evaluation of Hydrocarbon-Based Quench Oil¹

This standard is issued under the fixed designation D6710; the number immediately following the designation indicates the year of original adoption or, in the case of revision, the year of last revision. A number in parentheses indicates the year of last reapproval. A superscript epsilon (ϵ) indicates an editorial change since the last revision or reapproval.

1. Scope*

1.1 This guide covers information without specific limits, for selecting standard test methods for testing hydrocarbon-based quench oils for quality and aging.

1.2 The values stated in SI units are to be regarded as standard.

1.2.1 *Exception*—The units given in parentheses are for information only.

1.3 *This standard does not purport to address all of the safety concerns, if any, associated with its use. It is the responsibility of the user of this standard to establish appropriate safety, health, and environmental practices and determine the applicability of regulatory limitations prior to use.*

1.4 *This international standard was developed in accordance with internationally recognized principles on standardization established in the Decision on Principles for the Development of International Standards, Guides and Recommendations issued by the World Trade Organization Technical Barriers to Trade (TBT) Committee.*

2. Referenced Documents

2.1 ASTM Standards:²

- [D91 Test Method for Precipitation Number of Lubricating Oils](#)
- [D92 Test Method for Flash and Fire Points by Cleveland Open Cup Tester](#)
- [D94 Test Methods for Saponification Number of Petroleum Products](#)
- [D95 Test Method for Water in Petroleum Products and Bituminous Materials by Distillation](#)
- [D189 Test Method for Conradson Carbon Residue of Petroleum Products](#)
- [D445 Test Method for Kinematic Viscosity of Transparent and Opaque Liquids \(and Calculation of Dynamic Viscosity\)](#)
- [D482 Test Method for Ash from Petroleum Products](#)
- [D524 Test Method for Ramsbottom Carbon Residue of Petroleum Products](#)
- [D664 Test Method for Acid Number of Petroleum Products by Potentiometric Titration](#)
- [D974 Test Method for Acid and Base Number by Color-Indicator Titration](#)
- [D1298 Test Method for Density, Relative Density, or API Gravity of Crude Petroleum and Liquid Petroleum Products by Hydrometer Method](#)
- [D4052 Test Method for Density, Relative Density, and API Gravity of Liquids by Digital Density Meter](#)
- [D4175 Terminology Relating to Petroleum Products, Liquid Fuels, and Lubricants](#)
- [D4530 Test Method for Determination of Carbon Residue \(Micro Method\)](#)

¹ This guide is under the jurisdiction of ASTM Committee D02 on Petroleum Products, Liquid Fuels, and Lubricants and is the direct responsibility of Subcommittee D02.L0.06 on Non-Lubricating Process Fluids.

Current edition approved Aug. 1, 2017; Dec. 1, 2021. Published August 2017/January 2022. Originally approved in 2001. Last previous edition approved in 2012 as D6710–02 (2012); D6710–17. DOI: 10.1520/D6710-17.10.1520/D6710-21.

² For referenced ASTM standards, visit the ASTM website, www.astm.org, or contact ASTM Customer Service at service@astm.org. For *Annual Book of ASTM Standards* volume information, refer to the standard's Document Summary page on the ASTM website.

*A Summary of Changes section appears at the end of this standard

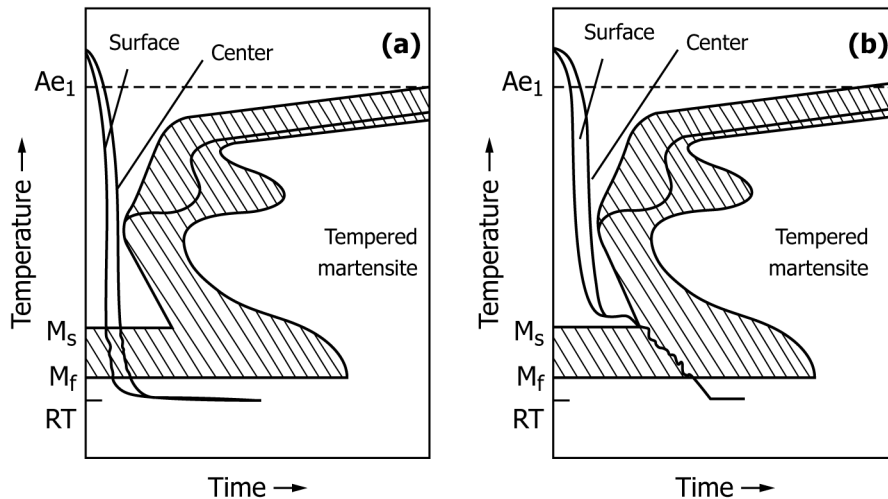

FIG. 1 (a) Conventional Quenching Cycle; (b) Martempering

- D6200 Test Method for Determination of Cooling Characteristics of Quench Oils by Cooling Curve Analysis
- D6304 Test Method for Determination of Water in Petroleum Products, Lubricating Oils, and Additives by Coulometric Karl Fischer Titration
- D7042 Test Method for Dynamic Viscosity and Density of Liquids by Stabinger Viscometer (and the Calculation of Kinematic Viscosity)
- 2.2 ISO Standards:³
- ISO 9950 Industrial Quenching Oils—Determination of Cooling Characteristics—Nickel-Alloy Probe Test Method, 1995-95-01

3. Terminology

3.1 Definitions of Terms Specific to This Standard:

3.1.1 For definitions of terms used in this guide, refer to Terminology **D4175**.

ASTM D6710-21

<https://standards.iteh.ai/catalog/standards/sis/4ee0-8ad0-10ba7e0acb82/astm-d6710-21> **Quench Processing**

3.1.2 *austenitization, n*—heating a steel containing less than the eutectoid concentration of carbon (about 0.8 mass %) to a temperature just above the eutectoid temperature to decompose the pearlite microstructure to produce a face-centered cubic (fcc) austenite-ferrite mixture.

3.1.3 *dragout, n*—solution carried out of a bath on the metal being quenched and associated handling equipment.

3.1.4 *martempering, n*—cooling steel from the austenitization temperature to a temperature just above the start of martensite transformation (M_s) for a time sufficient for the temperature to equalize between the surface and the center of the steel, at which point the steel is removed from the quench bath and air cooled as shown in Fig. 1 (1).⁴

3.1.5 *protective atmosphere, n*—any atmosphere that will inhibit oxidation of the metal surface during austenitization, or it may be used to protect the quenching oil, which may be an inert gas such as nitrogen or argon or a gas used for a heat-treating furnace.

3.1.6 *quench media, n*—any medium, either liquid (water, oil, molten salt, or lead, aqueous solutions of water-soluble polymers or salt-brines) or gas or combinations of liquid and gas (air at atmospheric pressure, or pressurized nitrogen, helium, hydrogen) such as air-water spray, used to facilitate the cooling of metal in such a way as to achieve the desired physical properties or microstructure.

³ Available from American National Standards Institute (ANSI), 25 W. 43rd St., 4th Floor, New York, NY 10036, <http://www.ansi.org>.

⁴ The boldface numbers in parentheses refer to the list of references at the end of this standard.

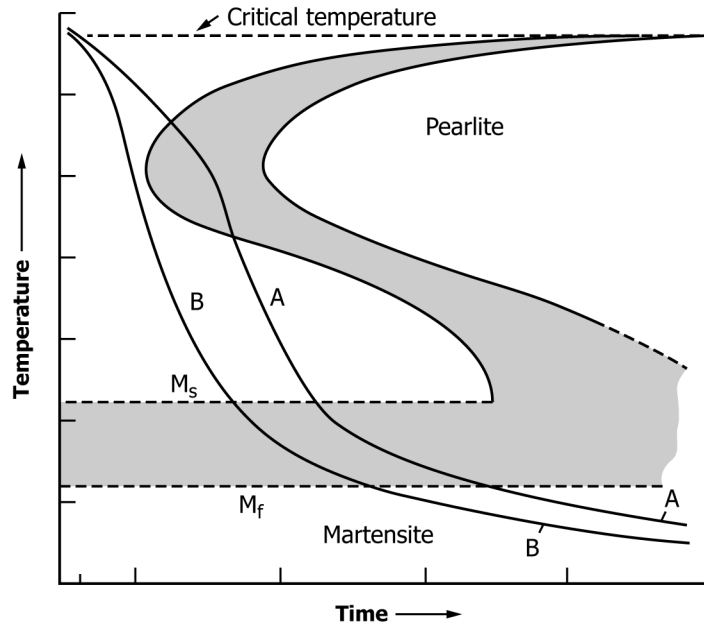

FIG. 2 Transformation Diagram for a Low-Alloy Steel with Cooling Curves for Various Quenching Media (A) High Speed Oil (B) Conventional Oil

iTeh Standards

(<https://standards.iteh.ai>)
Document Preview

3.1.7 *quench severity, n*—the ability of a quenching oil to extract heat from a hot metal traditionally defined by the quenching speed (cooling rate) at 1300 °F (705 °C) which was related to a Grossmann H-Value or Quench Severity Factor (H-Factor) (2).

3.1.8 *quenching, n*—cooling process from a suitable elevated temperature used to facilitate the formation of the desired microstructure and properties of a metal as shown in Fig. 2.

3.1.9 *transformation temperature, n*—characteristic temperatures that are important in the formation of martensitic microstructure as illustrated in Fig. 2; A_e – equilibrium austenitization phase change temperature; M_s – temperature at which transformation of austenite to martensite starts during cooling; and M_f – temperature at which transformation of austenite to martensite is completed during cooling.

Cooling Mechanisms

3.1.10 *convective cooling, n*—after continued cooling, the interfacial temperature between the cooling metal surface and the quenching oil will be less than the boiling point of the oil, at which point cooling occurs by a convective cooling process as illustrated in Fig. 3.

3.1.11 *full-film boiling, n*—upon initial immersion of hot steel into a quench oil, a vapor blanket surrounds the metal surface as shown in Fig. 3. This is full-film boiling also commonly called vapor blanket cooling.

3.1.12 *Leidenfrost temperature, n*—the characteristic temperature where the transition from full-film boiling (vapor blanket cooling) to nucleate boiling occurs which is independent of the initial temperature of the metal being quenched as illustrated in Fig. 4 (3).

3.1.13 *nucleate boiling, n*—upon continued cooling, the vapor blanket that initially forms around the hot metal collapses and a nucleate boiling process, the fastest cooling portion of the quenching process, occurs as illustrated in Fig. 3.

3.1.14 *vapor blanket cooling, n*—See *full-film boiling* (3.1.11).

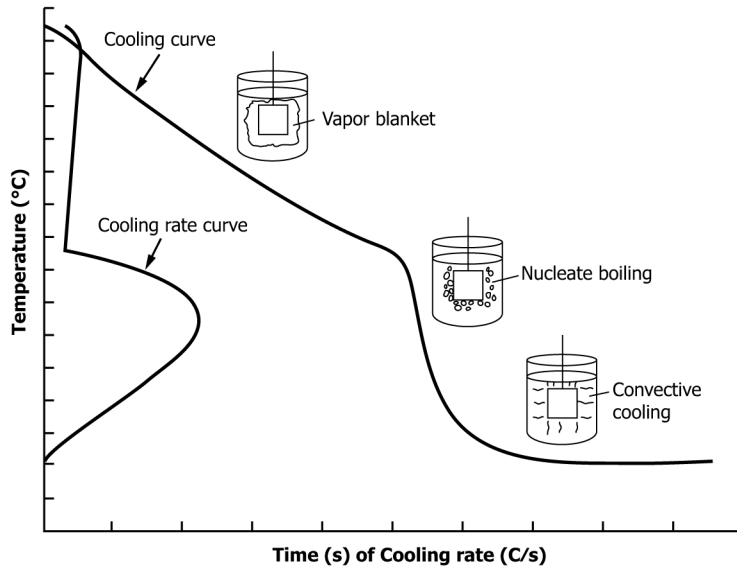

FIG. 3 Cooling Mechanisms for a Quenching Oil Superimposed on a Cooling Time-Temperature Curve and the Corresponding Cooling Rate Curve

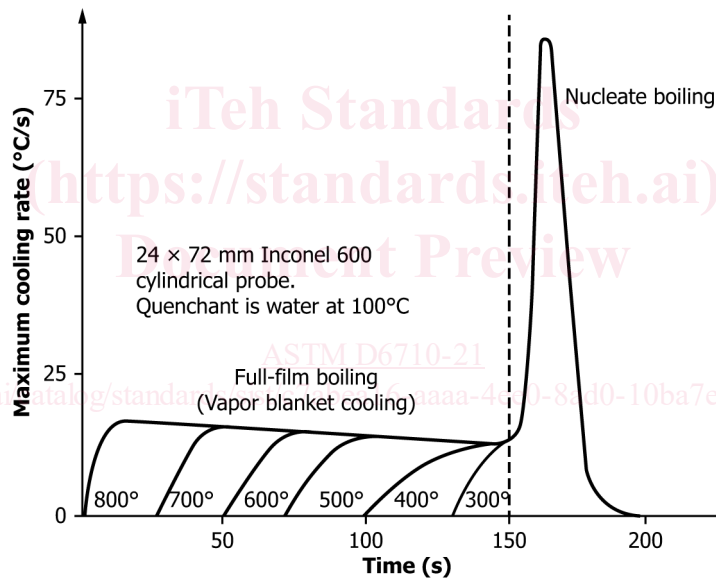

FIG. 4 Leidenfrost Temperature and its Independence of the Initial Temperature of the Metal Being Quenched

3.1.15 *wettability, n*—when a heated metal, such as the probe illustrated in Fig. 5, is immersed into a quenching medium, the cooling process shown in Fig. 6 occurs by initial vapor blanket formation followed by collapse, at which point the metal surface is wetted by the quenching medium (4).

Quench Oil Classification

3.1.16 *accelerated quenching oil, n*—also referred to as a fast or high-speed oil, these are oils that contain additions that facilitate collapse of the vapor blanket surrounding the hot metal immediately upon immersion into the quenching oil, as shown in Fig. 3.

3.1.17 *conventional quenching oil, n*—also called slow oils, these oils typically exhibit substantial film-boiling characteristics, commonly referred to as vapor blanket cooling due to relatively stable vapor blanket formation, illustrated mechanistically in Fig. 2.

ALL DIMENSIONS IN MILLIMETERS

Notes:

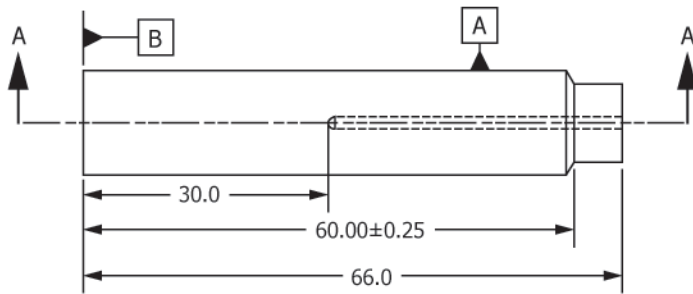

1. Dautm surface B not to be center drilled.
2. Material must be same as Type "K" thermocouple sheath material (Inconel 600).
3. Nominal hole diameter to be same as Type 'K' sheathed thermocouple within 1.45mm to 1.65 mm.
4. Full radius based on size specified in Note 3.
5. All surfaces $\nabla \frac{1}{1}$ unless otherwise specified.
6. Break all sharp edges.

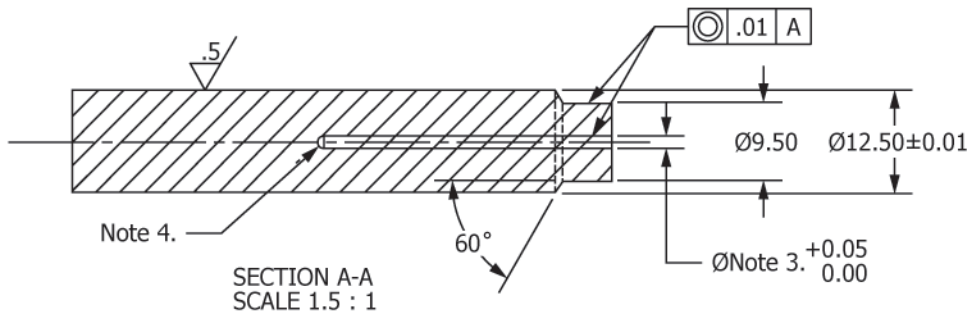

Tolerance Unless Otherwise Noted:
 X.X = ± 0.5
 X.XX = ± 0.1
 X.XXX = ± 0.05

(a) Probe Details

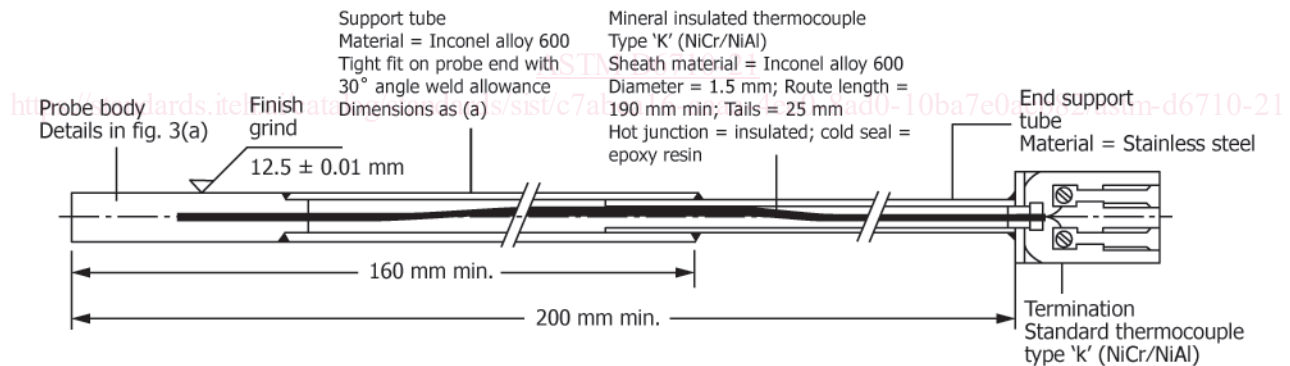

(b) General assembly

NOTE 1—Measurements are nominal. (From Test Method D6200.)

FIG. 5 Probe Details and Probe Assembly

3.1.18 *marquenching oils, n*—also referred to as marquenching oils or hot oils, these oils are typically used at temperatures between 95 °C to 230 °C (203 °F to 446 °F) and are usually formulated to optimize oxidative and thermal stability by the addition of antioxidants and because they are used at relatively high temperatures, a protective or non-oxidizing environment is often employed, which permits much higher use temperatures than open-air conditions.

3.1.19 *quenching oil, n*—although usually derived from a petroleum oil, they may also be derived from natural oils such as vegetable oils or synthetic oils such as poly(alpha olefin). They are used to mediate heat transfer from a heated metal, such as austenitized steel, to control the microstructure that is formed upon cooling and also control distortion and minimize cracking which may accompany the cooling process.

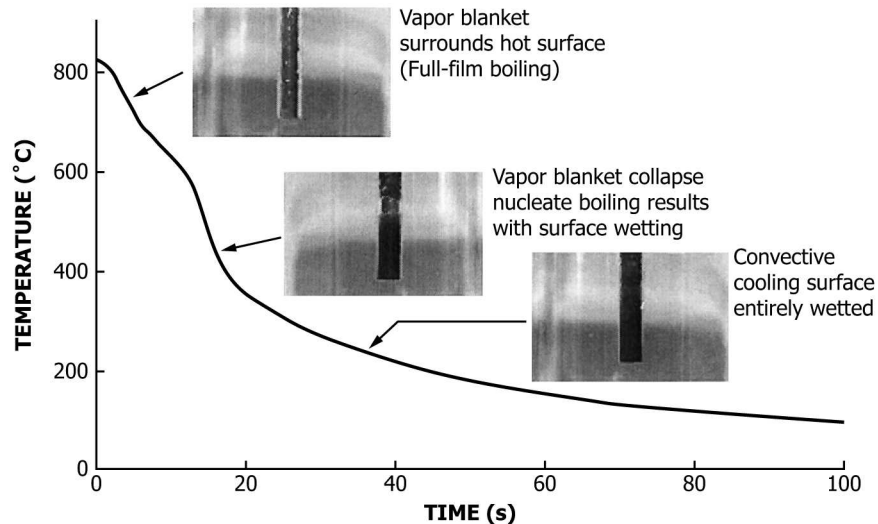

FIG. 6 Actual Cooling Process and Movement of the Wetting Front on a Metal Surface During a Quenching Process

Cooling Curve Terminology

3.1.20 *cooling curve, n*—a graphic representation of the temperature (T) versus cooling time (t) response of a probe. An example is illustrated in Fig. 3 (5).

3.1.21 *cooling curve analysis, n*—process of quantifying the cooling characteristics of a quenching oil based on the time-temperature profile obtained by cooling a preheated probe assembly (Fig. 5).

3.1.22 *cooling rate curve, n*—the first derivative (dT/dt) of the cooling time-temperature curve as illustrated in Fig. 3 (5).

4. Significance and Use

4.1 The significance and use of each test method will depend on the system in use and the purpose of the test method listed under Section 6. Use the most recent editions of the test methods.

5. Sampling

5.1 *Sampling Uniformity*—Flow is never uniform in agitated quench tanks. There is always variation of flow rate and turbulence from top to bottom and across the tank. This means that there may be significant variations of particulate contamination including sludge from oil oxidation and metal scale. For uniform sampling, a number of sampling recommendations have been developed.

5.1.1 Sampling Recommendations:

5.1.1.1 *Minimum Sampling Time*—The circulation pumps shall be in operation for at least 1 h prior to taking a sample from a quench system.

5.1.1.2 *Sampling Position*—For each system, the sample shall be taken from the same position each time that system is sampled. The sample shall be taken at the point of maximum flow turbulence. The position in the tank where the sample is taken shall be recorded.

5.1.1.3 *Sampling Valves*—If a sample is taken from a sampling valve, then sufficient quenching oil should be taken and discarded to ensure that the sampling valve and associated piping have been flushed, before the sample is taken.

5.1.1.4 *Sampling from Tanks with No Agitation*—If samples are to be taken from bulk storage tank or a quench tank with no agitation, then samples shall be taken from the top and bottom of the bulk system or quench tank. If this is not possible and the sample can only be taken from the top, then the laboratory report shall state that the results represent a sample taken from the top of the bulk system or quench tank and may not be representative of the total system.

5.1.1.5 *Effect of Quenching Oil Addition as Make-Up Due to Dragout*—It is important to determine the quantity and frequency of new quenchant additions, as large additions of new quench oil will have an effect on the test results, in particular the cooling curve. If a sample was taken just after a large addition of new quench oil, this shall be taken into consideration when interpreting the cooling curve of this oil sample.

5.1.1.6 *Sampling Containers*—Samples shall be collected in new containers. Under no circumstances shall used beverage or food containers be used because of the potential for fluid contamination and leakage.

6. Recommended Test Procedures

6.1 Performance-Related Physical and Chemical Properties:

6.1.1 *Kinematic Viscosity, (Test Method D445 or D7042)*—The performance of a quench oil is dependent on its viscosity, which varies with temperature and oil deterioration during continued use. Increased oil viscosity typically results in decreased heat transfer rates (6). Oil viscosity varies with temperature which affects heat transfer rates throughout the process.

6.1.1.1 The flow velocity of a quench oil depends on both viscosity and temperature. Some quench oils are used at higher temperatures, such as martempering oils, also known as hot-oils. Although the viscosity of a martempering oil may not fluctuate substantially at elevated temperatures, the oil may become almost solid upon cooling. Thus, the viscosity-temperature relationship (viscosity index) of a quench oil may be critically important from the dual standpoint of quench severity and flow velocity.

6.1.1.2 Typically kinematic viscosity determination by Test Method D445 or D7042 is used. Viscosity measurements are made at 40 °C (104 °F) for conventional or accelerated oils and also at 100 °C (212 °F) for martempering oils.

6.1.2 *Flash Point and Fire Point (Test Method D92)*—Use of a quench oil in an open system with no protective atmosphere shall be at least 60 °C to 65 °C lower than its actual open cup flash point to minimize the potential for fire. General guidelines have been developed for use temperatures of a quench oil relative to its flash point.

NOTE 1—There are various manufacturer-dependent guidelines for relating the suitability for use of a used quenching oil with respect to its flash point and they shall be followed. In the absence of such guidelines, it is recommended that the use temperature of a quenching oil in an open system with no protective atmosphere shall be more than 60 °C to 65 °C (140 °F to 149 °F) below its actual open-cup flash point. In closed systems where a protective atmosphere is used, the use temperature of the used quenching oil shall be at least 35 °C (95 °F) lower than its actual open-cup flash point.

6.1.3 *Density (Test Methods D1298 and D4052)*—The density of materials of similar volatility is dependent on the chemical composition, and in the case of quenching oils, the type of basestock used in formulation. The oxidative stability of quenching oils is also dependent on similar chemical composition trends, and thus density (or relative density) is an indirect indicator of oxidative stability. Density (or relative density) is measured at, or converted to, a standard reference temperature, normally either 15 °C or 60/60 °F, and these should be quoted alongside the result.

6.1.3.1 Test Method D1298 uses a hydrometer plus thermometer for measurement while Test Method D4052 uses a digital density meter based on an oscillating U-tube.

NOTE 2—Density or relative density are of limited value in the assessment of quality of a quenching oil.

6.2 *Aged Fluid Properties*—In addition to significant changes in fluid viscosity, oil degradation by thermal and oxidative processes may result in the formation of undesirable levels of volatile by-products, sludge formation, metal-staining products and particulates, all of which may result in loss of control of the quenching process.

6.2.1 *Acid Number (Test Methods D664 and D974)*—Quench oil oxidation results in the formation of carboxylic acids and esters. These by-products are similar to compounds that may be used as rate accelerating additives. These acids and esters significantly affect the viscosity and viscosity-temperature relationship of the oil, which in turn affect quench severity. Carboxylic acids may also act as wetting agents and increase the quench rate by increasing the wettability of the quench oil on the metal surface (7).

6.2.1.1 Oxidation of the oil may be monitored by tracking changes in the acid number. Because the fresh oil may be either alkaline or acidic, depending on the additives present, the absolute value of the acid number itself is not indicative of quality. However, changes in the acid number from the initial condition may be used to indicate the degree of oxidation. Increasing acid numbers generally indicate increasing amounts of aforementioned by-products. The acid number is determined by titrating the acidity of