



Designation: **B611–13 (Reapproved 2018) B611 – 21**

Standard Test Method for Determining the High Stress Abrasion Resistance of Hard Materials¹

This standard is issued under the fixed designation B611; the number immediately following the designation indicates the year of original adoption or, in the case of revision, the year of last revision. A number in parentheses indicates the year of last reapproval. A superscript epsilon (ϵ) indicates an editorial change since the last revision or reapproval.

1. ~~Scope~~ Scope*

1.1 This test method was developed for ranking the high-stress abrasion resistance of cemented carbides, but it has been successfully used on ceramics, cermets, and metal matrix hardfacings with a hardness over 55 ~~HRC~~. Rockwell hardness, C scale (HRC). The feature of this test method that discriminates it from other abrasion tests is that the abrasive is forced against the test specimen with a steel wheel with sufficient force to cause fracture of the abrasive particles. Some abrasion tests use rubber wheels to force abrasive against test surfaces (Test Methods G65; ~~G105~~; and G75G105). A rubber wheel produces low-stress abrasion while a steel wheel produces high-stress abrasion.

1.2 In summary, this is a high-stress laboratory abrasion test for hard materials using a water slurry of aluminum oxide particles as the abrasive medium and a rotating steel wheel to force the abrasive across a flat test specimen in line contact with the rotating wheel immersed in the slurry.

1.3 The values stated in SI units are to be regarded as standard. ~~No other units of measurement are included in this standard.~~

1.3.1 Exceptions—Subsection 4.4 and Table 1 use abrasive grit designations for particle size. The value given in parentheses is nominal dimension in micrometers based on sieve designation (Specification E11) and provided for information only. Subsection 6.2 uses the Rockwell hardness, B scale (HRB) as the standard unit of measure for hardness. In 6.4, 7.6, 7.7, and Table 1, rpm is the standard unit of measure for rotational speed.

1.4 *This standard does not purport to address all of the safety concerns, if any, associated with its use. It is the responsibility of the user of this standard to establish appropriate safety, health, and environmental practices and determine the applicability of regulatory limitations prior to use.*

1.5 *This international standard was developed in accordance with internationally recognized principles on standardization established in the Decision on Principles for the Development of International Standards, Guides and Recommendations issued by the World Trade Organization Technical Barriers to Trade (TBT) Committee.*

2. Referenced Documents

2.1 ASTM Standards:²

~~B31E11~~ Test Method for Density of Powder Metallurgy (PM) Materials Containing Less Than Two Percent Porosity Specification for Woven Wire Test Sieve Cloth and Test Sieves
G40 Terminology Relating to Wear and Erosion

¹ This test method is under the jurisdiction of ASTM Committee G02 on Wear and Erosion and is the direct responsibility of Subcommittee G02.30 on Abrasive Wear. Current edition approved Dec. 1, 2018; Nov. 1, 2021. Published December 2018; January 2022. Originally approved in 1976. Last previous edition approved in 2013; 2018 as B611–13; B611 – 13 (2018). DOI: 10.1520/B0611-13R18; 10.1520/B0611-21.

² For referenced ASTM standards, visit the ASTM website, www.astm.org, or contact ASTM Customer Service at service@astm.org. For Annual Book of ASTM Standards volume information, refer to the ~~standard's~~ standard's Document Summary page on the ASTM website.

*A Summary of Changes section appears at the end of this standard

G65 Test Method for Measuring Abrasion Using the Dry Sand/Rubber Wheel Apparatus

~~G75 Test Method for Determination of Slurry Abrasivity (Miller Number) and Slurry Abrasion Response of Materials (SAR Number)~~

G105 Test Method for Conducting Wet Sand/Rubber Wheel Abrasion Tests

2.2 American National Standard:³

ANSI B74.12 Specification for the Size of Abrasive Grain - Grinding Wheels, Polishing and General Industrial Uses

3. Terminology

3.1 *Definitions:* For definitions of terms found in this test method, please refer to Terminology Standard G40.

3.2 *Definitions of Terms Specific to This Standard:*

3.2.1 *abrasive wear, n*—wear due to hard particles or hard protuberances forced against and moving along a solid surface.

3.2.2 *high-stress abrasion, n*—progressive material removal from a hard solid surface by the action of hard particles rolling or sliding on that surface with sufficient force to cause fracture of the particles.

3.2.3 *slurry, n*—a suspension of solid material in liquid.

4. Summary of Test Method

4.1 The test specimen is a flat that is held in a vertical position tangent to a rotating steel wheel immersed in water slurry of aluminum oxide particles.

4.2 The normal force holding the test specimen against the wheel is high enough to cause fracture of abrasive particles that travel through the wheel/test specimen contact. The test metric is the volume of material worn from the test specimen in specified test duration and under specified test conditions.

4.3 The test specimen is weighed to determine mass loss, which is converted to a volume loss using the density of the test material.

4.4 The slurry used in the test is composed of a specified mass of ~~30-mesh~~ 30 grit (600 μm) aluminum oxide in a specified volume of water.

4.5 There may be a corrosion component to the material removal, but it is considered to be negligible since the test ~~time~~ duration is only ~~ten or twenty minutes (600 or 1200 seconds)~~ 10 min or 20 min.

5. Significance and Use

5.1 The extraction of minerals from the Earth's ~~mantle~~ crust usually requires fracturing rock with tools made from metals, ~~but which have been clad, overlaid, or covered~~ coated in some fashion with ~~hard materials~~ high hardness or wear-resistant materials, or both. Drilling, crushing, and moving rock involves high-stress abrasion on the surfaces that ~~make contact with~~ the rock. The stresses are high enough to ~~crush/fracture~~ crush or fracture the rock. This test method simulates this condition, and it is used to screen new materials for these types of applications. It can also be used as a quality control tool for materials destined for high-stress abrasion applications: slurry pumps, comminution equipment, recycling choppers, demolition equipment, etc.

5.2 Most abrasion tests use low-stress abrasion. The abrasive stays relatively intact during testing. High-stress abrasion simulates applications where the force between an abrasive substance and a tool/component will be high enough to crush the abrasive. If this describes an application under study, then this may be an appropriate test method to use.

6. Apparatus

6.1 *General Description*—Fig. 1 is a schematic of the test rig. The test specimen (a) contacts a steel wheel (b) on its centerline; the water/grit slurry (c) is held in a slurry vessel; ~~vanes, made from aluminum or steel~~ vanes (d) are on both sides of the steel wheel agitate the slurry. The vanes on the abrading wheel can be integral with the steel wheel, or they can be made from steel, aluminum or brass angle and attached to the wheel with fasteners. The agitating vanes can be slightly curved or flat. The length of the vanes

³ Available from American National Standards Institute (ANSI), 25 W. 43rd St., 4th Floor, New York, NY 10036, <http://www.ansi.org>.

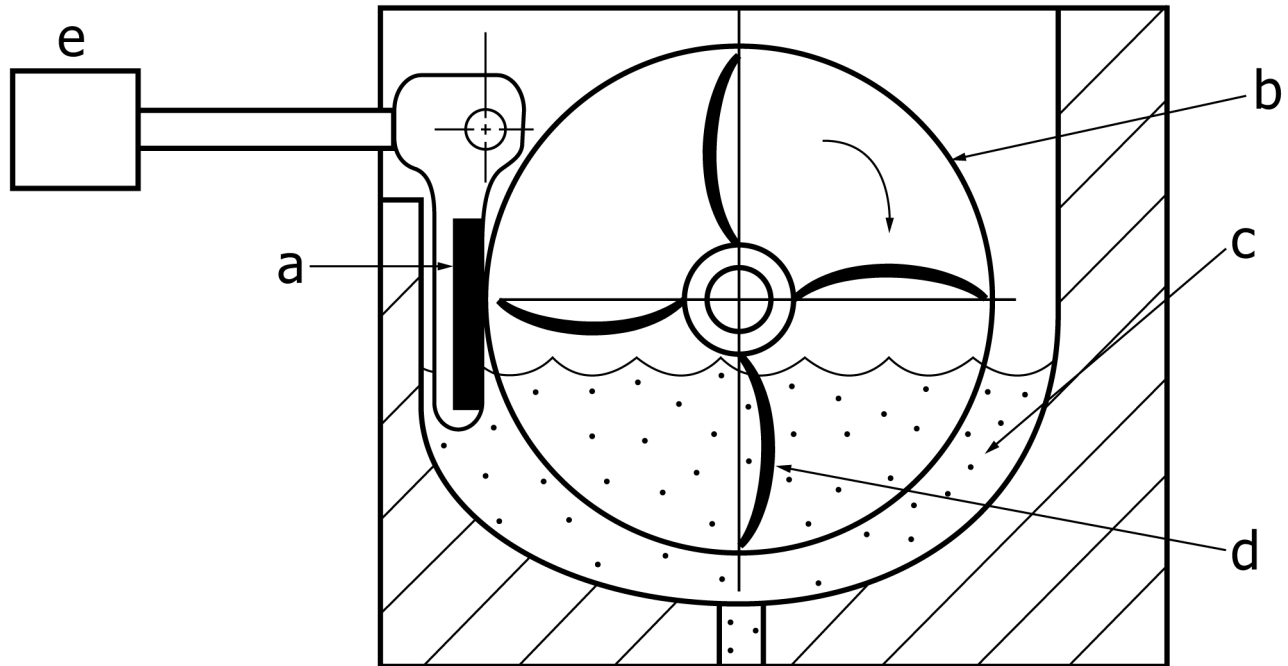

NOTE 1—"a" is the test specimen; "b" is the steel wheel; "c" is the test slurry; "d" are agitating vanes. They can have a slight curve as shown or flat. They can be from 3 to 13 mm high, but must have a minimum clearance of 3 mm on a side between the vanes and the vessel. They can be staggered so that the vanes on one side make an angle of 45° with the vanes on the other side. The mass producing the normal force is "e."

FIG. 1 Schematic of Test Rig

can be from 3 mm to 13 mm. The vanes must have a minimum clearance of 3 mm on a side between the vanes and the vessel. They can be staggered so that the vanes on one side make an angle of 45° with the vanes on the other side. The normal load (force) is applied by a mass (e) that is constant throughout the test. The slurry can be replenished if needed (Note: needed, since slurry may splash out of uncovered machines) during the test, and the test. The test duration and wheel rotational speed are fixed for the test.

6.2 *Abrading Wheel*—The wheel is made from AISI 1020 steel (80 HRB to 95 HRB); the outside diameter is $169.169 \text{ mm} \pm 0.1 \text{ mm}$ when new, and the wheel shall be discarded when its diameter wears below 165 mm. The steel wheel has a contact surface roughness of 0.5 μm to 0.8 μm (arithmetic surface roughness, Ra) as manufactured. A burr develops during use. It should not be removed. The wheel is not dressed between uses. After use, the surface becomes impregnated with alumina particles, and it has the appearance of a sand-blasted surface. Four agitating vanes are attached at 90° increments on both sides of the wheel. The vanes must have a minimum radial clearance of 3 mm with the test specimen when the wheel penetrates the test specimen to produce a wear scar (the vanes must not contact the specimen during testing). The wheel width is $12.712.7 \text{ mm} \pm 0.1 \text{ mm}$.

6.3 *Test Specimen*—The test specimen dimensions are shown in Fig. 2 (from Test Method G65). It in millimeters. The test surfaces should have a surface roughness in the range of 0.1 to 1 μm Ra on the test surfaces; an arithmetic surface roughness (Ra) less than 1 μm . Test specimen surfaces "a" and "b" must be flat and parallel within 0.01 mm. Chamfered edges are recommended.

6.4 *Drive Motor*—A 1 hp motor with a gear reduction unit has been found suitable for use, but other motors (hydraulic or DC motors, etc.) could be used if they have the torque requirements to rotate the wheel with a 200 N "braking" force applied to the outside diameter. The wheel can be directly mounted to the drive or it can be mounted on a spindle which is driven by a motor. Whatever the mechanism, the radial runout of the wheel shall be less than $\pm 0.01 \text{ mm}$ and widthwise runout shall be less than $\pm 0.05 \text{ mm}$. The motor speed shall be controlled to the specified rpm $\pm 2 \pm 2 \text{ rpm}$.

NOTE 1—While some standards that conform to metric practice use seconds as the basic unit for time and radians per second for rotational speed, rpm is used here to mean revolutions per minute of the wheel, a parameter which is historically used when conducting and documenting tests of this kind.

6.5 *Specimen Holder*—The centerline of the pivoting specimen holder should be aligned with the tangent point of the system with

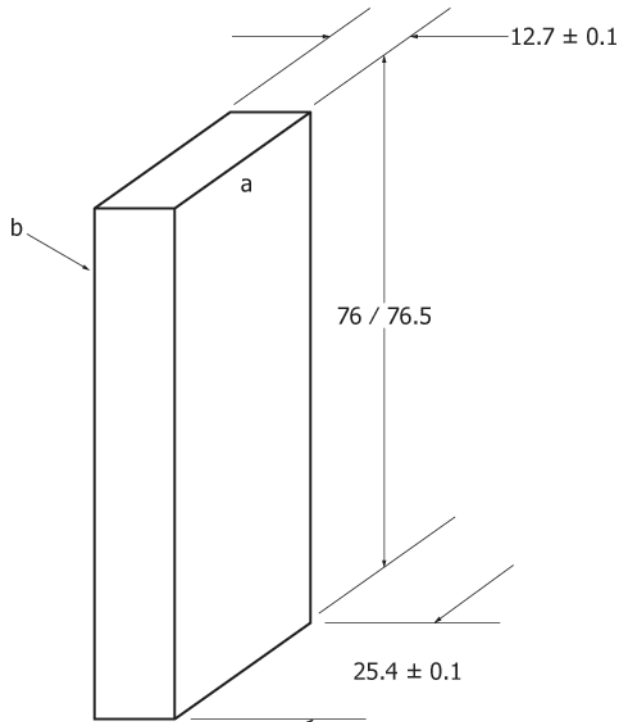

FIG. 2 Test Specimen Dimensions

a new wheel. The sideways movement of the holder should be less than 0.2 mm and it should be designed to place the wear scar in the center of the test specimen. Sub-sized test specimens can be held in special holders that allow the flat face of the test specimen in full wheel contact. If the wear scar runs into the holding device, the test specimen should be considered inadequate in size for testing with the standard procedure.

6.6 *Slurry Vessel*—The internal dimensions of the vessel that contains the slurry are shown in Fig. 3. All dimensions are in millimeters. The vessel can be made from metals or plastic and corrosion-resistant materials are preferred. In this design, a flat panel is fastened and sealed to the chamber shown to complete the vessel. Cutout “a” is an option clearance for the specimen pivot. Some test rigs do not need the spindle hole because the vessel clamps to a faceplate containing the wheel spindle. The slurry must be replaced for every test so a drain or other way of removing the slurry is advisable.

7. Procedure

7.1 *Specimen Preparation*—The test surface of the test specimen should be flat and not contain errors of form (ridges, waves, bumps, etc.) greater than $2.0 \mu\text{m}$. A test specimen can be tested on the front and backside as long as the holder references the specimen from the unworn surface.

7.2 *Specimen Cleaning*—Test specimens should be degreased with a solvent that does not attack the test surface or leave a film. Ultrasonic cleaning for a time duration from 30 s to 90 s in acetone has been found to be adequate for most metals and cermets.

7.3 *Specimen Weighing*—Weigh the test specimen to $\pm 0.001 \text{ g}$ three times and take the average weight as the starting weight. **Ferrous materials should be demagnetized before testing.**

7.4 *Specimen Mounting*—Affix the specimen in the loading arm without touching the test surface. The centerline of the test specimen should be in line with the centerline of the wheel. Apply the testing normal force by placing a mass on the specimen arm such that it develops a 200 N force pushing the test specimen against the wheel.

7.5 *Slurry Preparation*—Pour the 30-grit abrasive into the slurry vessel with the test specimen in place and loaded against the

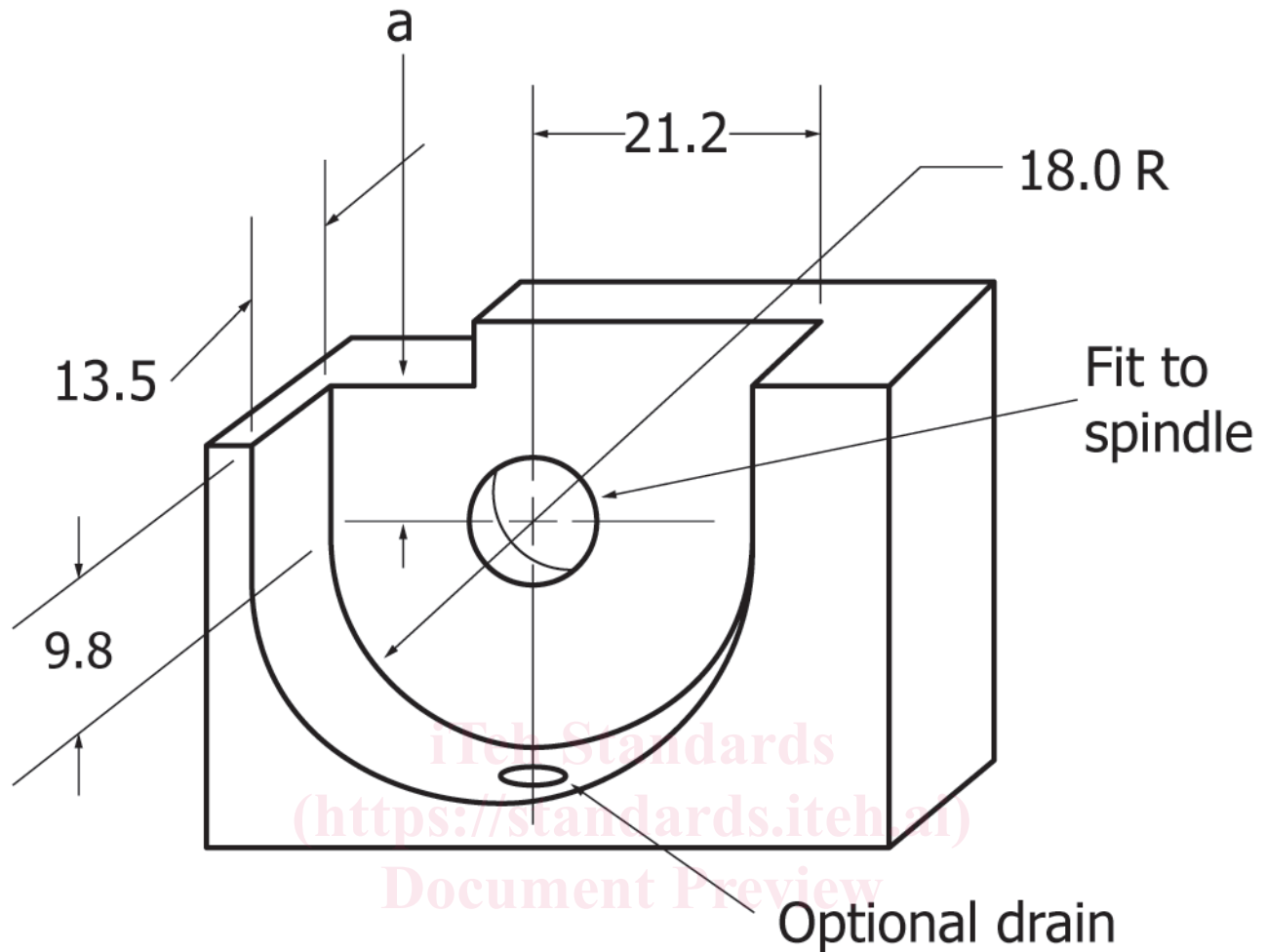

FIG. 3 Slurry Vessel

<https://standards.iteh.ai/catalog/standards/sist/d39e272d-91d0-408a-b7ce-dc2196558c8d/astm-b611-21>

wheel. The level of the grit should be ~~25~~25 mm to 30 mm below the wheel centerline. Determine the weight of grit used to fill the vessel by pouring the grit from a container that is weighed, reweighed when filled, and reweighed again after filling. The slurry is to have an abrasive/water ratio of 4 g of grit for every millilitre milliliter of water. For example, if it took 100 g of abrasive to fill the hopper to the required level (~~25/30 mm~~ (25 mm to 30 mm below centerline) then 25 mL of water must be added. Distilled water should be added to the vessel as wheel rotation commences. A fresh slurry is required for every test.

7.6 *Start Wheel Rotation After Loading and Slurry Filling*—The wheel speed shall be ~~50~~50 rpm or 100 rpm under load depending on the procedure used. Wheel revolutions shall be continuously recorded.

7.7 *Test Duration*—The test duration shall be:

- (1) *Procedure A*—1000 revolutions at 100 rpm (10 min)
- (2) *Procedure B*—1000 revolutions at 50 rpm (20 min)

7.8 *Slurry Make-Up*—The slurry is properly formulated and at the correct level when the grit is visibly carried up by the wheel and there is a crushing sound coming from the wheel/specimen contact. If grit is not carried up with the wheel, add more grit or remove slurry until grit is seen carrying up from the specimen/wheel contact.

7.9 *Weigh Sample Specimen After Testing*—The test specimen and vessel should be water rinsed to remove any grit and dried. Weigh the worn specimen to ± 0.001 g as in 7.3 and calculate the specimen mass loss.