



Designation: D495 – 22

Standard Test Method for High-Voltage, Low-Current, Dry Arc Resistance of Solid Electrical Insulation¹

This standard is issued under the fixed designation D495; the number immediately following the designation indicates the year of original adoption or, in the case of revision, the year of last revision. A number in parentheses indicates the year of last reapproval. A superscript epsilon (ϵ) indicates an editorial change since the last revision or reapproval.

This standard has been approved for use by agencies of the U.S. Department of Defense.

1. Scope*

1.1 This test method covers, in a preliminary fashion, the differentiation of similar materials' resistance to the action of a high-voltage, low-current arc close to the surface of insulation, when a conducting path is formed causing the material to become conducting due to the localized thermal and chemical decomposition and erosion.

1.2 The usefulness of this test method is very severely limited by many restrictions and qualifications, some of which are described in the following paragraphs and in Section 5. Generally, this test method shall *not* be used in material specifications. Whenever possible, alternative test methods shall be used, and their development is encouraged.

1.3 This test method will not, in general, permit conclusions to be drawn concerning the relative arc resistance rankings of materials that are potentially subjected to other types of arcs: for example, high voltage at high currents, and low voltage at low or high currents (promoted by surges or by conducting contaminants).

1.4 The test method is intended, because of its convenience and the short time required for testing, for preliminary screening of material, for detecting the effects of changes in formulation, and for quality control testing after correlation has been established with other types of simulated service arc tests and field experience. Because this test method is usually conducted under clean and dry laboratory conditions rarely encountered in practice, it is possible that the prediction of a material's relative performance in typical applications and in varying "clean to dirty" environments will be substantially altered (Note 1). Caution is urged against drawing strong conclusions without corroborating support of simulated service tests and field testing. Rather, this test method is useful for preliminary evaluation of changes in structure and composition

¹ This test method is under the jurisdiction of ASTM Committee D09 on Electrical and Electronic Insulating Materials and is the direct responsibility of Subcommittee D09.12 on Electrical Tests.

Current edition approved Jan. 15, 2022. Published January 2022. Originally approved in 1938. Last previous edition approved in 2014 as D495 – 14. DOI: 10.1520/D0495-22.

without the complicating influence of environmental conditions, especially dirt and moisture.

NOTE 1—By changing some of the circuit conditions described herein it has been found possible to rearrange markedly the order of arc resistance of a group of organic insulating materials consisting of vulcanized fiber and of molded phenolic and amino plastics, some containing organic, and some inorganic, filler.

1.5 While this test method uses dry, uncontaminated specimen surfaces, Test Method D2132, Test Methods D2303, and Test Method D3638 employ wet, contaminated specimen surfaces. Their use is recommended for engineering purposes and to assist in establishing some degree of significance to this test method for quality control purposes.²

1.6 This test method is not applicable to materials that do not produce conductive paths under the action of an electric arc, or that melt or form fluid residues that float conductive residues out of the active test area thereby preventing formation of a conductive path.

1.7 The values stated in inch-pound units are to be regarded as standard. The values given in parentheses are mathematical conversions to SI units that are provided for information only and are not considered standard.

1.8 *This standard does not purport to address all of the safety concerns, if any, associated with its use. It is the responsibility of the user of this standard to establish appropriate safety, health, and environmental practices and determine the applicability of regulatory limitations prior to use.* For specific precautionary statements, see 6.1.14, 6.1.19, Section 7, and 10.1.1.

NOTE 2—Due to the deficiencies covered in Section 1, Committee D09 has proposed that without significant proposed improvements this standard be withdrawn in 2027 during its next 5 year review. This notice is provided so that referencing standards can transition.

1.9 *This international standard was developed in accordance with internationally recognized principles on standardization established in the Decision on Principles for the*

² Also helpful is Test Method D2302 for Wet Tracking Resistance of Electrical Insulating Materials with Controlled Water-to-Metal Discharges. This test method was withdrawn and last appeared in the 1982 Annual Book of ASTM Standards, Part 39.

*A Summary of Changes section appears at the end of this standard

Development of International Standards, Guides and Recommendations issued by the World Trade Organization Technical Barriers to Trade (TBT) Committee.

2. Referenced Documents

2.1 ASTM Standards:³

- D1711 Terminology Relating to Electrical Insulation
- D2132 Test Method for Dust-and-Fog Tracking and Erosion Resistance of Electrical Insulating Materials
- D2303 Test Methods for Liquid-Contaminant, Inclined-Plane Tracking and Erosion of Insulating Materials
- D3638 Test Method for Comparative Tracking Index of Electrical Insulating Materials
- D6054 Practice for Conditioning Electrical Insulating Materials for Testing (Withdrawn 2012)⁴

2.2 IEC Standard:

- IEC 61621 Dry Solid Insulating Materials—Resistance Test To High-Voltage, Low-Current Arc Discharges⁵

NOTE 3—IEC 61621 is technically equivalent to D495, and is directly based upon Test Method D495. IEC 61621 describes only the tungsten electrodes, and does not include the stainless steel electrodes.

3. Terminology

3.1 Definitions:

3.1.1 For definitions of terms used in this test method, refer to Terminology D1711.

3.2 Definitions of Terms Specific to This Standard:

3.2.1 *arc resistance, n*—the total elapsed time in seconds from the start of this test procedure until failure occurs (see Section 14).

3.2.2 *failure, n*—the end-point of the test procedure employed in this test method (see Section 14).

3.2.3 *normal orientation, n*—a test condition in which the electrodes are located on the upper surface of the specimen.

3.2.4 *inverted orientation, n*—a test condition in which the electrodes are located on the under surface of the specimen.

3.2.4.1 *Discussion*—Tests made with inverted orientation are more severe than tests made with normal orientation. Reduced data dispersion has been encountered when testing certain materials using inverted orientation. With other materials, increased data dispersion has been encountered, especially with materials that evolve considerable gas during test.

3.3 Abbreviations:

3.3.1 The stainless steel strip electrodes are referred to as s.s.s. electrodes.

4. Significance and Use

4.1 The high-voltage, low-current type of arc resistance test is intended to simulate only approximately such service

³ For referenced ASTM standards, visit the ASTM website, www.astm.org, or contact ASTM Customer Service at service@astm.org. For *Annual Book of ASTM Standards* volume information, refer to the standard's Document Summary page on the ASTM website.

⁴ The last approved version of this historical standard is referenced on www.astm.org.

⁵ Available from American National Standards Institute (ANSI), 25 W. 43rd St., 4th Floor, New York, NY 10036, <http://www.ansi.org>.

conditions as exist in alternating current circuits operating at high voltage, but at currents limited to units and tens of milliamperes.

4.2 In order to distinguish more easily among materials that have low arc resistance, the early stages of this test method are mild, and the later stages are successively more severe. The arc occurs intermittently between two electrodes resting on the surface of the specimen, in normal or inverted orientation. The severity is increased in the early stages by successively decreasing to zero the interval between flashes of uniform duration, and in later stages by increasing the current.

4.3 Four general types of failure have been observed:

4.3.1 Many inorganic dielectrics become incandescent, whereupon they are capable of conducting the current. Upon cooling, however, they return to their earlier insulating condition.

4.3.2 Some organic compounds burst into flame without the formation of a visible conducting path in the substance.

4.3.3 Others are seen to fail by “tracking,” that is, a thin wiry line is formed between the electrodes.

4.3.4 The fourth type occurs by carbonization of the surface until sufficient carbon is present to carry the current.

4.4 Materials often fail within the first few seconds after a change in the severity stage. When comparing the arc resistance of materials, much more weight shall be given to a few seconds that overlap two stages than to the same elapsed time within a stage. Thus, there is a much greater difference in arc resistance between 178 and 182 s than between 174 and 178 s.

NOTE 4—Some investigators have reported attempts to characterize the remaining insulating value of the damaged area after failure by allowing the specimen to cool to room temperature, without disturbance of the original position of the electrodes, and then either (1) measuring the insulation resistance between the electrodes or (2) determining the percentage of breakdown voltage remaining relative to that obtained on an undamaged area of the specimen. A recommended circuit arrangement and test procedure for carrying out the second of these two means of characterizing the remaining insulating value of the damaged area is described in Appendix X1. Still another, and obvious, method of reevaluating the damaged area after failure is to repeat the arc resistance test after the specimen has cooled, with the electrodes undisturbed from their original positions. However, keep in mind that none of these methods will be universally applicable because of the severe physical damage to the test area in many instances.

5. Interferences

5.1 Changes in both the timing of the intermittent arc and the current, as well as other changes affecting the nature of the discharge, has the potential to affect the duration of a test of most specimens taken from a group of dissimilar materials. Any of these changes have the potential to drastically alter a material's position in order of rank. Regardless of the conditions of anticipated use, do not use data obtained by this test method to infer that the materials examined occupy an unchanging quality relationship to each other.

5.2 This test method describes two electrode systems: stainless steel strip and tungsten rod. When testing materials with poor to moderate arc resistance (up to 180 s), use the stainless steel strip electrodes as the preferred technique. This technique decreases the variability often associated with the use of rod

electrodes on materials having poor or moderate arc resistance. All of the factors that affect the disparate behavior of rod electrodes on such materials have not yet been fully reported. It is permissible to make additional tests with rod electrodes, so as to provide a basis for comparison with other data obtained with such electrodes. For values of arc resistance greater than 180 s, the use of the tungsten rod electrodes is recommended because the corners of the stainless steel strip electrodes erode appreciably under such conditions. It is possible that results obtained with the use of the tungsten rod electrode system will be different from those obtained with the use of the stainless steel strip electrode system.

6. Apparatus

6.1 The apparatus (see Fig. 1 for electrical circuit) is specified to maximize data reproducibility among different test sets. The arc obtained will be relatively quiet, rather than the crackly blue spark characteristic of a condenser discharge. Primary voltage control is made by a variable transformer rather than by a variable inductance because of its proved deleterious effect on the performance of the arc.

6.1.1 *Transformer, T_v* —A self-regulating transformer (non-power factor corrected) with a rated primary potential of 115 V at 60 Hz ac, a rated secondary potential (on open circuit) of 15 000 V, and a rated secondary current (on short circuit) of 0.060 A.

6.1.2 *Variable Autotransformer, T_a* —An autotransformer rated at 7 A or more, and nominally adjustable up to 135 V.

6.1.3 *Voltmeter, V_1* —An ac voltmeter, readable to 1 V in the range 90 to 130 V, is permanently connected across the output of the autotransformer to indicate the voltage supplied to the primary circuit.

NOTE 5—A constant primary voltage supply is recommended. Commercially available line voltage stabilizers that do not distort the voltage wave form are suitable.

6.1.4 *Milliammeter, A* —An ac milliammeter capable of reading from 10 to 40 mA with an error of not over $\pm 5\%$. Before use, this meter shall be calibrated in a test circuit containing no arc gap. Since this milliammeter is used only when setting up or making changes in the circuit, it is to be shorted out by a by-pass switch when not in use.

NOTE 6—Although provision has been made for the suppression of radio-frequency components of current in the arc, it will often be desirable to check for their presence when the apparatus is first constructed. This is done by use of a suitable thermocouple-type r-f milliammeter temporarily inserted in series with the milliammeter.

6.1.5 *Current Control Resistors, $R_{10}, R_{20}, R_{30}, R_{40}$* —Four resistors are required in series with the primary of T_v but in parallel with each other. These resistors must be adjustable to permit exact settings of the currents during calibration. R_{10} is always in the circuit to provide a 10 mA current. Its value is approximately 60 Ω , with a current rating of at least $1\frac{1}{4}$ A. Closing switch S_{20} , to add R_{20} in parallel with R_{10} , will provide a 20 mA arc current. R_{20} is about 50 Ω with a current rating of at least $1\frac{3}{4}$ A. Similarly, R_{30} and R_{40} have values of about 30 Ω and 15 Ω respectively, with associated current ratings of 2 and 5 A. These resistors, when switched in, provide arc currents of 30 mA and 40 mA respectively.

6.1.6 *Suppressing Resistor, R_3* —Rated at 15 000 Ω and at least 24 W. This resistor, along with the inductors in 6.1.7, is used to suppress parasitic high frequency in the arc circuit.

6.1.7 *Air Core Inductors*—Inductance totaling from 1.2 to 1.5 H is obtained from about 8 coils of No. 30 cotton- or enamel-covered wire. A single coil of this inductance must not be used. Each coil consists of 3000 to 5000 turns of wire wound on insulating nonmetallic cores of about $\frac{1}{2}$ in. (12.7 mm) diameter and $\frac{5}{8}$ in. (15.9 mm) inside length.

6.1.8 *Interrupter, I* —This motor-driven device is used to give the required cycles for the three lower steps of the test by opening and closing the primary circuit according to the schedule in Table 1, with an accuracy of $\pm \frac{1}{120}$ s or better. A synchronous motor driving three appropriate sets of cams which actuate the contactor switches has been found useful.

6.1.9 *Timer, TT* —A stop watch or electric interval timer operating at 115 V ac, accurate to 1 s.

6.1.10 *Indicator Lamp, IL* —A6 W, 115 V lamp with a 2000 Ω resistor, R_1 , in series. This lamp indicates the interrupting cycle being used and permits the operator to start the first

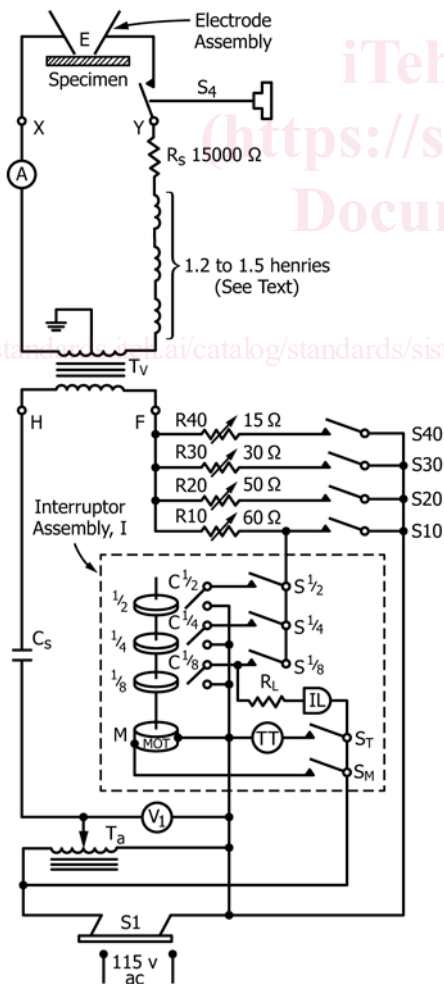

NOTE 1—Switches S_M to S_{40} are aligned in the sequence of their closing, from bottom to top, during a test.

FIG. 1 Arc-Resistance Test Circuit

TABLE 1 Sequence of 1-min Current Steps

Step	Current, mA	Time Cycle ^A	Total Time, s
1/8 10	10	s on, 1/4 s off	60
1/4 10	10	s on, 3/4 s off	120
1/2 10	10	s on, 1/4 s off	180
10	10	continuous	240
20	20	continuous	300
30	30	continuous	360
40	40	continuous	420

^A In the earlier steps an interrupted arc is used to obtain a less severe condition than the continuous arc; a current of less than 10 mA produces an unsteady (flaring) arc.

cycle of each test in a uniform manner by closing $S_{1/8}$ just after the lamp is extinguished.

6.1.11 *Control Switches*—Toggle switches are convenient. All shall be of the size rated at 3 A and 110 to 125 V ac, except S_1 and S_{40} , which require 10 A ratings.

6.1.12 *Safety Interlocking Contactor, C_S* —Rated at 10 A and 110 to 125 V ac, this interlocking contactor is installed so that raising the draft shield around the electrode assembly will open the contactor and thus remove high voltage from the electrodes.

6.1.13 *Interruptor Contactors, $C_{1/8}$, $C_{1/4}$, $C_{1/2}$* —Normally-open spring contactors, rated at 1 1/4 A (or better) and 125 V ac. These contactors are operated by the interrupted cams, thus closing and opening the primary circuit and providing the intermittent arc cycles listed in Table 1.

6.1.14 *High Voltage Switch, S_4* —A single-pole, single-throw switch insulated for 15 000 V ac. This switch must be isolated from the operator by a suitable enclosure through which projects an insulating handle of sufficient length to ensure operator safety.

6.1.15 *Wiring*—All wiring in the arc circuit must be of ignition wire rated at 15 kV or higher, and must be so disposed that it and any circuit components are not readily accessible when energized.

6.1.16 *Sharpening Jig for Tungsten Rod Electrodes*—A steel jig for securing the electrodes during sharpening to ensure finishing the pointed tips to the proper geometry (see Fig. 2).

6.1.17 *Stainless Steel Strip Electrodes*—Cut 0.006 in. (0.15 mm) thick stainless steel into 1/2 by 1 in. (12.7 by 25.4 mm) strips. (The edges must be free of burrs.) Bend each strip slightly in the middle of the long dimension to form an angle of approximately 160° (see Fig. 3).

6.1.18 *Tungsten Rod Electrodes* (see 5.2 for restrictions)—Make the electrodes from 3/32 in. (2.4 mm) diameter tungsten rod (tungsten welding rod has been found suitable) which is free of cracks, pits, or rough spots. Use rods about 1 3/4 in. (45 mm) long in the electrode assembly, or use shorter rod lengths fastened into a square shank (see Fig. 4) by swaging, brazing, or silver soldering, leaving an exposed length of about 3/4 in. (19 mm). The shank ensures correct orientation of the electrode point after sharpening (see 9.2.2), although correct orientation of the simple rod electrode will be obtained by



FIG. 2 Grinding and Polishing Block with Tungsten Rod Electrode in Place

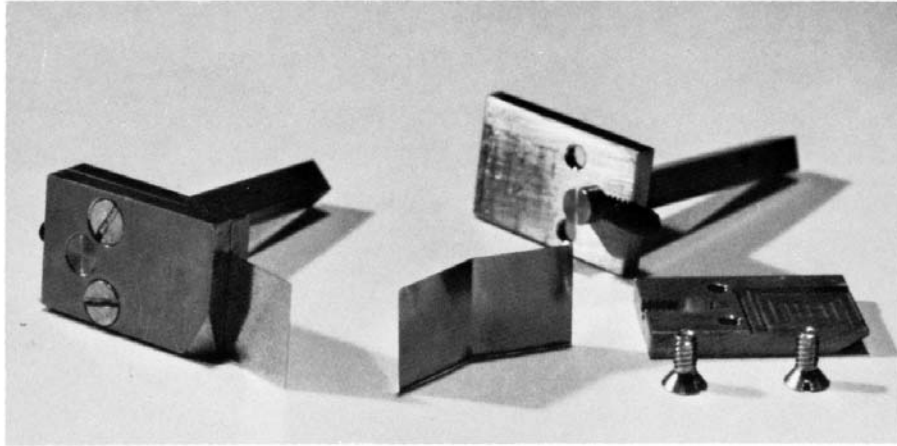

FIG. 3 Strip Electrodes and Holders

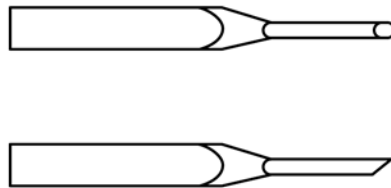

FIG. 4 Top and Side Views of Tungsten Rod Electrode

adjustment of the rod in the electrode assembly. In either type of rod electrode, grind the end of the rod at a 30° angle to the axis (see Fig. 4) to achieve a flat elliptical face. Exercise care in grinding to prevent cracking or chipping.

6.1.19 *Electrode Assemblies*—These assemblies provide a means of holding the electrodes and specimen and of applying the arc to the top surface of the specimen. Construct each assembly, whether for stainless steel strip electrodes or for tungsten rod electrodes, so that the top surface of each specimen is at the same level height. Provide ample air space below the specimen, especially in the region directly below the test area. Adjust each electrode so that it rests independently with a force of 50 ± 5 g on the top of the specimen. Provide a transparent shield around the assembly to protect the specimen from air drafts, and allow venting of combustion products in cases where specimens give off toxic smoke or gases during the test. Protect the operator from inadvertent contact with the electrodes, and provide a clear view of the arc from a position slightly above the plane of the specimen.

6.1.19.1 *Stainless Steel Strip Electrode Assembly* (see Fig. 3, Fig. 5, Fig. 6, and Fig. 7)—Place two stainless steel strip electrodes on the top of the specimen surface with the corners down and spaced 0.250 ± 0.003 in. (6.35 ± 0.08 mm) apart, and at angles of 45° to a line joining the corners. Either use an electrode holder such as the one in Fig. 3, Fig. 6, and Fig. 7, or use the rod electrode assembly with the rods separated and resting on the stainless steel strip electrodes.

6.1.19.2 *Tungsten Rod Electrode Assembly* (see Fig. 4 and Fig. 8)—Position the electrodes so that they lie in the same vertical plane and are both inclined 35° from the horizontal (thus inclined 110° between their axes). Check to see that the minor axes of the elliptical tip surfaces are horizontal, and

space the tips 0.250 ± 0.003 in. (6.35 ± 0.08 mm) apart. The proper orientation will automatically be obtained if the following factors are controlled: (a) axis of tungsten rod is perpendicular to the axis of the support rod, (b) support rods are gripped in the pivot blocks in a position such that the axis of each electrode is inclined at 35° when the support rods are horizontal, (c) electrodes are mounted in square shanks and sharpened in a correctly made jig, and (d) the spacing between electrode tips is adjusted with the support rods in a horizontal position. If electrodes are not mounted in square shanks, obtain proper orientation by adjusting and rotating the electrodes after they are inserted in the appropriate electrode assembly.

7. Safety Precautions

7.1 **Warning**—It is possible that lethal voltages will be present during this test. It is essential that the test apparatus, and all associated equipment potentially electrically connected to it, be properly designed and installed for safe operation. Solidly ground all electrically conductive parts that any person might come in contact with during the test. Provide means for use at the completion of any test to ground any parts which: were at high voltage during the test; will potentially have acquired an induced charge during the test; will potentially retain a charge even after disconnection of the voltage source. Thoroughly instruct all operators in the proper way to conduct tests safely. When making high voltage tests, particularly in compressed gas or in oil, it is possible that the energy released at breakdown will be sufficient to result in fire, explosion, or rupture of the test chamber. Design test equipment, test chambers, and test specimens so as to minimize the possibility of such occurrences and to eliminate the possibility of personal injury.

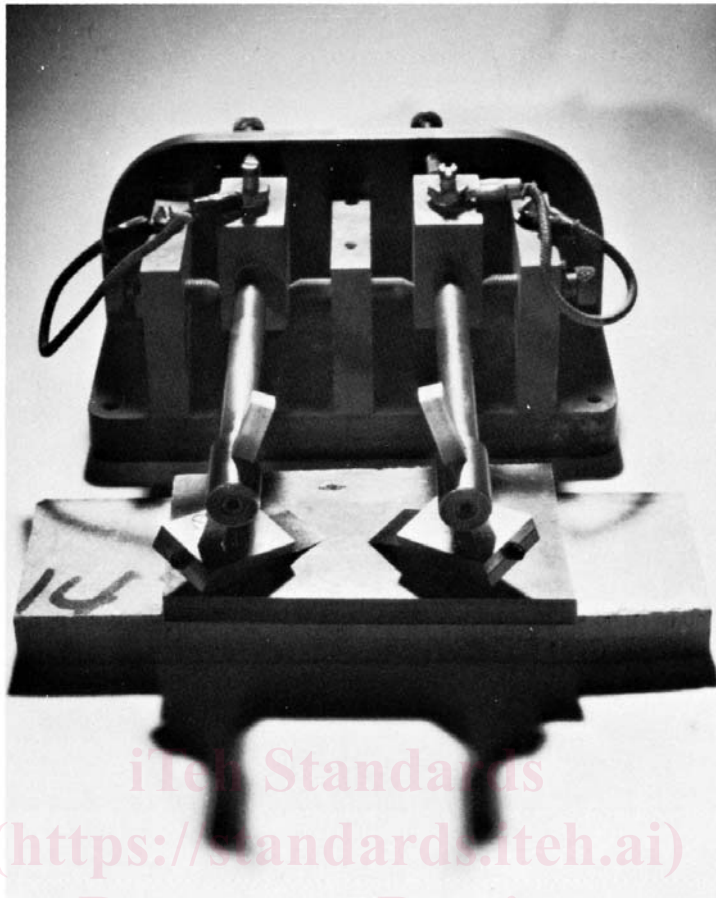
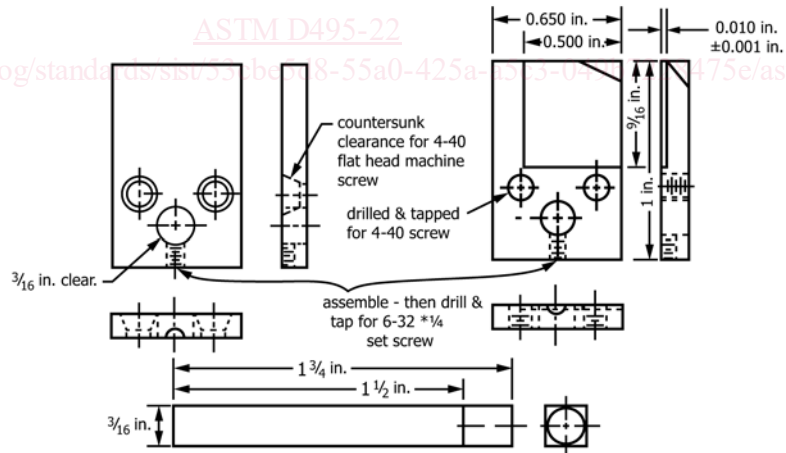

FIG. 5 Strip Electrodes in Place



in.	mm	in.	mm
0.001	0.025	9/16	14.3
0.010	0.254	0.650	16.5
1/16	4.8	1	25.4
0.500	12.7	1 1/2	38
		1 3/4	44.4

NOTE 1—The 0.010-in. slot and the corresponding angled corner must be made to provide a left and a right holder.

FIG. 6 Holder Detail

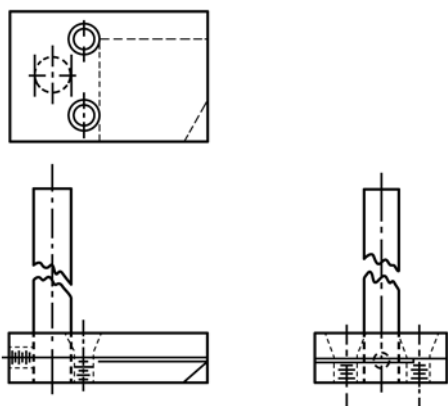

FIG. 7 Strip Electrode Holder Assembly

8. Specimens and Number of Tests

8.1 For standard comparison of materials, test at least five specimens 0.125 ± 0.010 in. (3.17 ± 0.25 mm) in thickness. Make each test on a flat surface of the specimen, with each test area not closer than $\frac{1}{4}$ in. (6.4 mm) to the specimen edge nor closer than $\frac{1}{2}$ in. (12.7 mm) to a previously tested area. Test thin materials by first clamping them together tightly to form a specimen as close as possible to the recommended thickness.

8.2 When testing molded parts, apply the arc to a location deemed most significant. Make all comparison tests of parts in similar locations.

8.3 Dust, moisture, or finger marks are known to affect the time required to track. If affected, clean specimens or parts with a cloth containing water or other suitable solvent before conditioning. Wipe such specimens with a dry cloth immediately before testing.

NOTE 7—If the purpose of the test is to ascertain the effect of contamination, disregard these instructions. However, state the nature and quantity of contaminant present (if known) in the report.

9. Cleaning and Sharpening Electrodes

9.1 *Stainless Steel Electrodes*—Use two new corners of the stainless steel strip electrodes for each test. Replace electrodes after four tests. Inspect the electrode corners to be sure that they are free of burrs.

9.2 Tungsten Rod Electrodes:

9.2.1 If excessive accumulations of products of decomposition occur, clean the rod electrodes gently with laboratory tissues. The application of a continuous 40 mA arc for approximately 1 min (without a specimen in place) is known to be an effective technique of cleaning the electrodes.

9.2.2 Sharpen the tungsten rod electrodes when examination of the tip edge shows that it has been rounded to a diameter of 0.030 in. (0.08 mm), or when burrs or rough edges are observable at 15 \times magnification. First, polish the rod surface by rotating it on its axis using successive grades of emery paper (from No. 1 to 000) held between the fingers. Then mount the electrode in the sharpening jig (see Fig. 2) with its elliptical face flush with the surface of the jig. Hold the surface against a rotating polishing disk or rub against a stationary machinist's flat, using No. 1 to No. 000 emery or emery paper to make

successive cuts. The resulting elliptical face shall be a highly polished surface inclined at $30 \pm 1^\circ$ to the axis of the electrode. The electrodes are considered properly sharpened and polished when no burrs or rough edges are observable at 15 \times magnification.

10. Calibration

10.1 With the circuit connected as shown in Fig. 1, calibrate the test apparatus for correct voltage and current as follows:

10.1.1 In making these calibrations, the operator comes into contact with the high voltage wiring of the secondary circuit. Therefore, the circuit must be de-energized by opening S_1 before each change in connection is made.

10.1.2 *Open Circuit Operating Voltage*—Attach an electrostatic voltmeter across the secondary of T_v . With S_4 open and S_{10} and S_1 closed, initially adjust the autotransformed, T_a , to provide an open circuit operating voltage of 12 500 V.

10.1.3 *Adjustment of Secondary Current*—With the correctly spaced electrodes resting on a lava or ceramic block and with the draft shield closed, close switches S_1 , S_4 , and S_{10} . Adjust R_{10} to give the required current of 10 mA as indicated by the milliammeter A. If the apparatus is checked for r-f current in the secondary when the equipment is first set up, the r-f thermocouple milliammeter (see Note 6) shall read 10 mA to indicate proper suppression of r-f. Open S_4 again and readjust T_a to give an open circuit secondary voltage of 12 500 V as indicated by an electrostatic voltmeter. Repeat this procedure until no further adjustment is necessary to obtain 10 mA and 12 500 V. Note the reading on the voltmeter V at this time while the arc is continuous at 10 mA. Maintain this voltage (typically around 110 to 115 V) for all subsequent calibration and testing. Next, close S_{20} along with S_{10} , thus placing R_{20} in parallel with R_{10} . Adjust R_{20} to give an arc current of 20 mA. Close S_{30} and adjust R_{30} for a 30 mA current, and, finally, close S_{40} and adjust R_{40} to give a 40 mA current.

11. Conditioning

11.1 Condition specimens prior to testing in accordance with Procedure A of Practice D6054, unless shown that the omission of this step has no effect. For some insulation, the effect of exposure to humid atmosphere is of interest, in which case the use of Procedure C of Practice D6054 is recommended.

11.2 If specimens have been kept at a temperature close to or below the dew point of the surroundings in which the test will be run, prevent condensation on the specimens by warming the specimens in a dry atmosphere.

NOTE 8—Warming the specimens in a 50 °C oven for about 30 min is suitable in most cases.

12. Choice of Electrodes

12.1 This test method describes two electrode systems:

- 12.1.1 Stainless steel strip (s.s.s.) electrodes, and
- 12.1.2 Tungsten rod electrodes.

12.2 The choice of electrode system depends upon the result obtained with the s.s.s. electrode system. If the s.s.s. electrode system yields an arc resistance time less than 180 s, use the