



Designation: D3638 – 21<sup>ε1</sup>

# Standard Test Method for Comparative Tracking Index of Electrical Insulating Materials<sup>1</sup>

This standard is issued under the fixed designation D3638; the number immediately following the designation indicates the year of original adoption or, in the case of revision, the year of last revision. A number in parentheses indicates the year of last reappraisal. A superscript epsilon ( $\epsilon$ ) indicates an editorial change since the last revision or reappraisal.

<sup>ε1</sup> NOTE—Subsections 7.1.1, 7.1.2, and 9.4 were corrected editorially in January 2022.

## 1. Scope\*

1.1 This test method evaluates in a short period of time the low-voltage (up to 600 V) track resistance or comparative tracking index (CTI) of materials in the presence of aqueous contaminants.

1.2 The values stated in metric (SI) units are to be regarded as standard. The inch-pound equivalents of the metric units are approximate.

1.3 This test method is technically equivalent to the version of IEC Publication 112 cited in 2.2. However, the 2007 version of IEC 60112 Fourth Edition yields numerical CTI values that are very likely to differ significantly from this test method.

1.4 *This standard does not purport to address all of the safety concerns, if any, associated with its use. It is the responsibility of the user of this standard to establish appropriate safety, health, and environmental practices and determine the applicability of regulatory limitations prior to use.*

1.5 *This international standard was developed in accordance with internationally recognized principles on standardization established in the Decision on Principles for the Development of International Standards, Guides and Recommendations issued by the World Trade Organization Technical Barriers to Trade (TBT) Committee.*

## 2. Referenced Documents

2.1 *ASTM Standards:*<sup>2</sup>

[D1711 Terminology Relating to Electrical Insulation](#)

[D6054 Practice for Conditioning Electrical Insulating Mate-](#)

[rials for Testing](#) (Withdrawn 2012)<sup>3</sup>

2.2 *IEC Publications:*<sup>4</sup>

[IEC 112 Method for the determination of the proof and the comparative tracking indices of solid insulating materials](#)

[IEC 60112 Method for the determination of the proof and the comparative tracking indices of solid insulating materials](#)

[IEC 60664-1 Insulation coordination for equipment within low-voltage supply systems – Part 1: Principles, requirements and tests, 2020 Edition 3.0](#)

2.3 *ANSI/UL Publication:*<sup>5</sup>

[ANSI/UL 840 Standard for Insulation Coordination Including Clearances and Creepage Distances for Electrical Equipment, January 6, 2005, 3<sup>rd</sup> edition](#)

## 3. Terminology

3.1 *Definitions:*

3.1.1 *track, n*—a partially conducting path of localized deterioration on the surface of an insulating material.

3.1.2 *tracking, n*—the process that produces tracks as a result of the action of electric discharges on or close to an insulation surface.

3.1.3 *tracking, contamination, n*—tracking caused by scintillations that result from the increased surface conduction due to contamination.

3.1.4 *tracking resistance, n*—the quantitative expression of the voltage and the time required to develop a track under the specified conditions.

3.1.5 For other terminology, refer to Terminology [D1711](#).

3.2 *Definitions of Terms Specific to This Standard:*

<sup>1</sup> This test method is under the jurisdiction of ASTM Committee D09 on Electrical and Electronic Insulating Materials and is the direct responsibility of Subcommittee D09.12 on Electrical Tests.

Current edition approved Jan. 1, 2021. Published February 2021. Originally approved in 1977. Last previous edition approved in 2012 as D3638 – 12. DOI: 10.1520/D3638-21E01.

<sup>2</sup> For referenced ASTM standards, visit the ASTM website, [www.astm.org](http://www.astm.org), or contact ASTM Customer Service at [service@astm.org](mailto:service@astm.org). For *Annual Book of ASTM Standards* volume information, refer to the standard's Document Summary page on the ASTM website.

<sup>3</sup> The last approved version of this historical standard is referenced on [www.astm.org](http://www.astm.org).

<sup>4</sup> Available from International Electrotechnical Commission (IEC), 3, rue de Varembe, 1st floor, P.O. Box 131, CH-1211, Geneva 20, Switzerland, <https://www.iec.ch>.

<sup>5</sup> Available from American National Standards Institute (ANSI), 25 W. 43rd St., 4th Floor, New York, NY 10036, <http://www.ansi.org>.

\*A Summary of Changes section appears at the end of this standard

3.2.1 *comparative tracking index, n*—an index for electrical insulating materials which is arbitrarily defined as the numerical value of that voltage which will cause failure by tracking when the number of drops of contaminant required to cause failure is equal to 50.

3.2.1.1 *Discussion*—The voltage value is obtained from a plot of the number of drops required to cause failure by tracking versus the applied voltage.

3.2.2 *failure, n*—an attribute of an electrical circuit containing an electrical-current-sensing device that rapidly decreases the applied voltage to zero if the current in the circuit exceeds a predetermined limit.

**4. Summary of Test Method**

4.1 The surface of a specimen of electrical insulating material is subjected to a low-voltage alternating stress combined with a low current which results from an aqueous contaminant (electrolyte) dropped between two opposing electrodes every 30 s. The voltage applied across these electrodes is maintained until the current between them exceeds a predetermined value, constituting a failure. Additional specimens are tested at other voltages to establish a relationship between applied voltage and number of drops to failure through graphical means. The numerical value of the voltage which causes failure with the application of 50 drops of the electrolyte is arbitrarily called the comparative tracking index. This index provides an indication of the relative track resistance of the material.

**5. Significance and Use**

5.1 Electrical equipment can fail as a result of electrical tracking of insulating material that is exposed to various contaminating environments and surface conditions. This method is an accelerated test which at relatively low test voltages, provides a comparison of the performance of insulating materials under wet and contaminated conditions. The comparative tracking index is not related directly to the suitable operating voltage in service.

5.2 When organic electrical insulating materials are subjected to conduction currents between electrodes on their surfaces, many minute tree-like carbonaceous paths or tracks are developed near the electrodes. These tracks are oriented randomly, but generally propagate between the electrodes under the influence of the applied potential difference. Even-

tually a series of tracks spans the electrode gap, and failure occurs by shorting of the electrodes.

5.3 The conditions specified herein are intended to produce a condition conducive to the formation of surface discharges and possible subsequent tracking. Test conditions are chosen to accelerate a process that is reproducible. Consequently, they rarely reproduce the varied conditions found in actual service. Therefore, while tracking tests serve to differentiate materials under given conditions, results of tracking tests cannot be used to infer either direct or comparative service behavior of an application design. Rather, the results provide a tool for judging the suitability of materials for a given application. The suitability can only be verified through testing the design in actual end use or under conditions which simulate end use as closely as possible.

5.4 The results have been used for insulation coordination of equipment with rated voltage up to 1000 Vac or 1500 Vdc connected to low-voltage supply systems (higher voltages permitted in internal circuits). The complete principles of insulation coordination involve the consideration of the combination of clearances, creepage distances, and the properties of solid insulation used to constitute the insulation system. Users of these results need to consider the overvoltage levels and the methods of control which will be utilized and establish the pollution degree to which the product insulation system will be expected to be subjected.

NOTE 1—See IEC 60664-1:2020, Table F.5 (Creepage Distances to Avoid Failure Due to Tracking) and UL 840, Table 9.1 (Minimum Acceptable Creepage Distances) as examples for the use of comparative tracking index results as part of insulation coordination.

**6. Apparatus**

6.1 The simplified electrical circuitry used in this test is illustrated in Fig. 1. For necessary information on the cleanliness of apparatus, see Annex A1. The essential components are as follows:

6.1.1 *Variable Power Source*, consisting of a transformer type supply, such as the combination T1 and T2 in Fig. 1, with a variable output of 0 to 1000 V, 60 Hz capable of maintaining a current of 1 A (1 kVA).

6.1.2 *Voltmeter (V1)*, capable of measuring the varying a-c output of the power source up to 600 V with an accuracy of at least ±2.5 % of full scale.

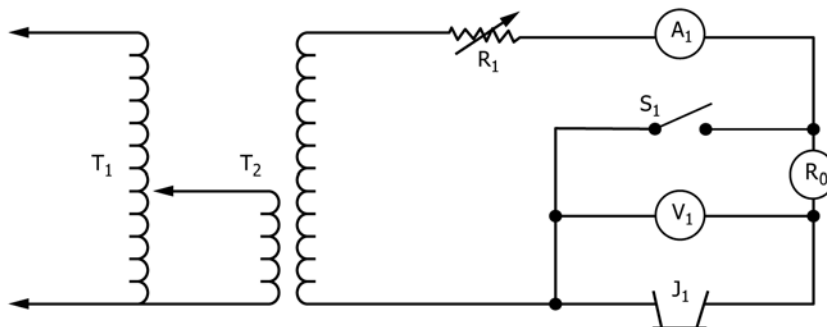

FIG. 1 Electrical Circuit Components

6.1.3 *Ammeter (A1)*, with a range of 0 to 1 A a-c and an accuracy of at least  $\pm 10\%$  of full scale.

6.1.4 *Current Limiting Resistor (R1)*, continuously variable, wire wound, rated at greater than 1 A.

6.1.5 *Shorting Switch (S1)*, single-pole single-throw rated at 1000 V and greater than 1 A.

6.1.5.1 A shorting switch is optional. See [Annex A2](#).

6.1.6 *Over-current Relay (R0)*, which is inserted in the circuit shall not trip at currents up to 0.1 A. Use a relay having a tripping time on short circuit of at least 0.5 s and a current limited on short circuit to 1 A with a tolerance of  $\pm 10\%$  at a power factor of 0.9 to 1.0.

6.1.6.1 The tripping action can be accomplished with suitable electronic circuitry or with a commercial circuit breaker.

6.1.7 *Testing Fixture*, adjustable platform which supports the specimen and electrode setup.

6.1.8 *Platinum Electrodes*, having a rectangular cross section measuring  $5.0 \pm 0.1$  by  $2.0 \pm 0.1$  mm ( $0.197 \pm 0.004$  by  $0.079 \pm 0.004$  in.), extending 20 mm (0.8 in.) minimum from suitable mounting shanks ([Fig. 2](#)). Machine the end of each electrode to form a  $30 \pm 2^\circ$  chisel-point edge, having a radius from 0.05 to 0.10 mm, extending along the 5 mm (0.2-in.) side of the electrode. This is the radius that generally results from polishing a “0 mm” radius electrode. Since the direction of polish can influence the results, polish all electrodes in a direction perpendicular to the long dimension of the electrode face.

6.1.9 *Dropping Apparatus*, capable of dropping the electrolyte precisely as specified in Section 9. Include in the dropping apparatus device for electrically starting and stopping the dropping of the electrolyte as well as a counting device for monitoring the number of drops. The orifice diameter of the drop mechanism is approximately 1.5 mm. If necessary, adjust this diameter so as to obtain the proper drop size in accordance with [9.2](#). The channel for electrolyte flow is called “the needle” in [Annex A1](#).

## 7. Reagents

7.1 *Electrolyte Solution of Ammonium Chloride in Water:*

7.1.1 Prepare a solution of ammonium chloride at an approximate concentration of 0.1 % by dissolving 1 g of reagent grade ammonium chloride in 1 L of water. Use water having a

volume resistivity not less than  $0.5 \text{ M}\Omega\text{-cm}$  at  $23^\circ\text{C}$ . Allow the solution to stand overnight in a covered, but not sealed, container.

7.1.2 Calculate the resistivity of the solution using a conductivity cell and an a-c bridge, or meter, following the manufacturer’s instructions. If the resistivity is  $385 \pm 5 \Omega\text{-cm}$  at  $23 \pm 0.5^\circ\text{C}$ , the solution is suitable for use in the test. If the resistivity is outside the above limits, adjust the concentration until these limits are observed. Adjustment is accomplished by adding water or  $\text{NH}_4\text{Cl}$ .

7.1.3 Calibrate the conductivity cell with 0.01 *N* potassium chloride calibrating solution which is available from the cell manufacturer.

## 8. Test Specimens

8.1 Test specimens shall be any approximately flat surface provided that the area is sufficient to ensure that no liquid flows away from the test electrodes during the test. The thickness of the test specimen shall be 2.5 mm or more (see [8.5](#)).

NOTE 2—Test specimens with flat surfaces of not less than 20 by 20 mm (0.8 by 0.8 in.) are recommended to reduce the probability of electrolyte flowing away from the test electrodes. Smaller sizes may be used so long as there is no electrolyte loss.

8.2 In as much as variations in values can result from a lack of uniformity of dispersion of the material throughout any molded specimen or from surface imperfections on any specimen, care must be taken to prepare specimens that are as uniform as possible, both within the particular specimen and from one specimen to another.

8.3 Condition specimens in accordance with Procedure A of Practice [D6054](#).

8.4 Specimens must be clean of dust, dirt, oil, or other contaminants with smooth surfaces and essentially free from scratches.

8.5 Test thin materials by first clamping them together tightly to form a specimen having a thickness as close as possible to the recommended thickness.

## 9. Calibration and Standardization

9.1 Partially support the electrodes by adjustable pivot arms so that the electrodes rest on the test specimen surface as shown in [Fig. 2](#), exerting a force of 100 g (3.5 oz).

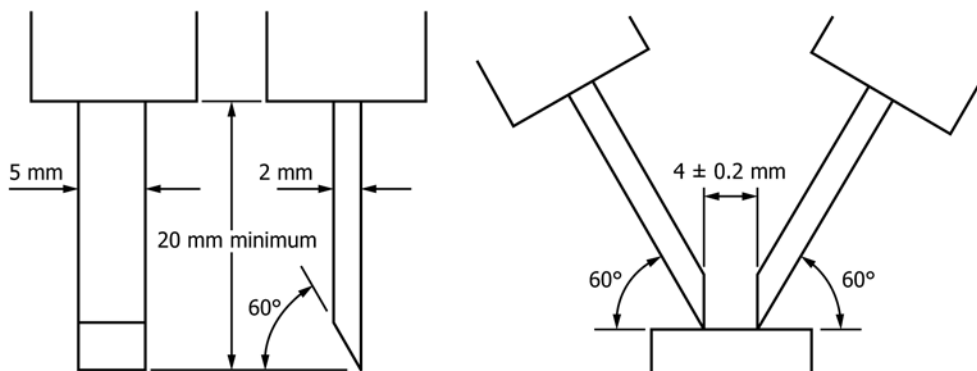

FIG. 2 Electrodes (Radius 0.05 to 0.1 mm)

9.2 The drop height for the electrolyte shall be no more than 40 mm (1.6 in.) above the electrode gap. The holding device is designed to store an aqueous solution and deliver periodically a measured drop to the specimen. The drop size shall be  $20 + 5 - 0 \text{ mm}^3$  (0.0015 in.<sup>3</sup>) and the drop rate is to be 1 drop/30 ± 5 s. (The drop size can be measured by using a small calibrated graduate to accumulate a number of drops to obtain an accurate reading.)

9.3 Allow approximately 15 drops of electrolyte to drop from the apparatus into a beaker or other container so as to remove any solution with a high concentration of ammonium chloride.

9.4 Reform the electrodes when the edges are rounded in excess of 0.1 mm radius or when burrs or rough edges are observable at 15× magnification. Replace electrodes when sharpening or machining fails to restore the specific dimensions of the electrodes and the quality of the chisel edge.

9.5 Reproducibility of results is improved by abrasive cleaning of the electrodes after every two or three tests.

9.6 The power source is set to the desired voltage with only air between the electrodes (switch open). The shorting switch is closed and the current limiting resistor adjusted to give a reading of 1 A.

**10. Procedure**

10.1 Conduct the test in a draft-free, clean environment at a temperature of 20 ± 5 °C.

10.2 Fill the dropping assembly with solution and set the counter to 0.

10.3 Set the power source to the desired voltage and adjust in accordance with 9.6.

10.4 Place the test specimen on the supporting platform so that the electrodes can be placed on the specimen. Where the material is substantially anisotropic, tests shall be made in the direction of the features and orthogonal to them. Results from the direction giving the lower values shall be used, unless otherwise specified.

10.5 Position the electrodes as shown in Fig. 2 so that the chisel edges contact the specimen at a 60° angle between electrodes and so that the chisel faces are parallel in the vertical plane and are separated by 4 ± 0.2 mm (0.16 ± 0.008 in.).

NOTE 3—It is recommended that contact of the electrodes with the specimen shall be such that when a light source is so placed that the light reaches the eye along the surface of the specimen, no light is visible between the specimen and the electrodes. If light is visible due to the electrode edges having become rounded, the edges must be reground.

10.6 Open the shorting switch and begin the sequence of drops with the time interval between drops set at 30 ± 5 s.

10.7 Continue until tracking occurs. This condition is usually well defined with a sudden surge occurring in the current (from essentially 0 to almost 1 A) accompanied by a corresponding drop in voltage.

10.8 It is preferable to use separate test specimens for each test. If several tests are to be made on the same test specimen, care should be taken to ensure that the testing points are

sufficiently far from each other so that splashes, fumes, or erosion from the testing point will not contaminate or influence the other areas to be tested nor is there any electrolyte loss over an edge.

10.9 Obtain one reading on each of five specimens of a sample to be tested at any given voltage. Repeat this process in accordance with 10.8, at different voltage levels such that at least two levels produce failures in less than 50 drops and two levels greater than 50 drops.

10.10 Limit any test voltage to 600 V or less. Testing at higher voltages will generate electric discharges above the surface of the specimen, which will produce erroneous results.

10.11 When testing at voltages below 150 V, and there is not sufficient energy to vaporize completely the electrolyte solution that has been placed between the electrodes, flooding can result. If flooding occurs, discontinue the test.

**11. Calculation**

11.1 Plot the number of drops of electrolyte at failure versus voltage. On the curve note the voltage which corresponds to 50 drops. This is the comparative track index (CTI) (see Fig. 3).

**12. Report**

12.1 Report the comparative tracking index for each material tested, and include the following:

- 12.1.1 Description of the material tested,
- 12.1.2 Resistivity of the electrolyte,
- 12.1.3 Test temperature,
- 12.1.4 Test voltage and number of drops of electrolyte to failure, for each test,
- 12.1.5 The CTI value in volts derived in accordance with 11.1, and
- 12.1.6 Visual observations of specimen behavior, such as melting of the specimen, flame ignition (if it occurs), and the type of erosion that has occurred on the surface of the test specimen between the electrodes.

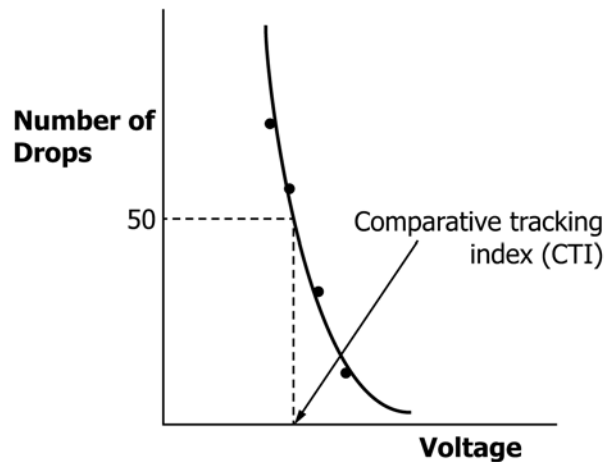

FIG. 3 Typical Tracking Voltage Curve