



Designation: D8257/D8257M – 22

Standard Specification for Mechanically Attached Polymeric Roof Underlayment Used in Steep Slope Roofing¹

This standard is issued under the fixed designation D8257/D8257M; the number immediately following the designation indicates the year of original adoption or, in the case of revision, the year of last revision. A number in parentheses indicates the year of last reapproval. A superscript epsilon (ϵ) indicates an editorial change since the last revision or reapproval.

1. Scope

1.1 This specification addresses mechanically attached polymeric roof underlayment used in steep slope roofing.

1.2 The objective of this specification is to provide a finished product that will be used as a water-shedding underlayment layer on steep sloped roofs prior to and after installation of the primary roof covering.

1.3 The values stated in either SI units or inch-pound units are to be regarded separately as standard. The values stated in each system may not be exact equivalents; therefore, each system shall be used independently of the other. Combining values from the two systems may result in nonconformance with the standard.

1.4 *This standard does not purport to address all of the safety concerns, if any, associated with its use. It is the responsibility of the user of this standard to establish appropriate safety, health, and environmental practices and determine the applicability of regulatory limitations prior to use.*

1.5 *This international standard was developed in accordance with internationally recognized principles on standardization established in the Decision on Principles for the Development of International Standards, Guides and Recommendations issued by the World Trade Organization Technical Barriers to Trade (TBT) Committee.*

2. Referenced Documents

2.1 *ASTM Standards:*²

[D146/D146M Test Methods for Sampling and Testing Bitumen-Saturated Felts and Woven Fabrics for Roofing and Waterproofing](#)

[D228/D228M Test Methods for Sampling, Testing, and Analysis of Asphalt Roll Roofing, Cap Sheets, and](#)

¹ This specification is under the jurisdiction of ASTM Committee D08 on Roofing and Waterproofing and is the direct responsibility of Subcommittee D08.02 on Steep Roofing Products and Assemblies.

Current edition approved Feb. 1, 2022. Published February 2022. Originally approved in 2020. Last previous edition approved in 2020 as D8257/D8257M – 20. DOI: 10.1520/D8257_D8257M-22.

² For referenced ASTM standards, visit the ASTM website, www.astm.org, or contact ASTM Customer Service at service@astm.org. For *Annual Book of ASTM Standards* volume information, refer to the standard's Document Summary page on the ASTM website.

[Shingles Used in Roofing and Waterproofing](#)

[D751 Test Methods for Coated Fabrics](#)

[D1079 Terminology Relating to Roofing and Waterproofing](#)

[D1204 Test Method for Linear Dimensional Changes of Nonrigid Thermoplastic Sheet or Film at Elevated Temperature](#)

[D4533/D4533M Test Method for Trapezoid Tearing Strength of Geotextiles](#)

[D4798/D4798M Practice for Accelerated Weathering Test Conditions and Procedures for Bituminous Materials \(Xenon-Arc Method\)](#)

[D4869/D4869M Specification for Asphalt-Saturated Organic Felt Underlayment Used in Steep Slope Roofing](#)

[D5035 Test Method for Breaking Force and Elongation of Textile Fabrics \(Strip Method\)](#)

[E96/E96M Test Methods for Gravimetric Determination of Water Vapor Transmission Rate of Materials](#)

[F1667 Specification for Driven Fasteners: Nails, Spikes, and Staples](#)

[G113 Terminology Relating to Natural and Artificial Weathering Tests of Nonmetallic Materials](#)

[G151 Practice for Exposing Nonmetallic Materials in Accelerated Test Devices that Use Laboratory Light Sources](#)

[G155 Practice for Operating Xenon Arc Lamp Apparatus for Exposure of Materials](#)

3. Terminology

3.1 *Definitions*—For definitions of terms used in this specification, refer to Terminologies [D1079](#) and [G113](#).

3.2 *Definitions of Terms Specific to This Standard:*

3.2.1 *polymeric roof underlayment*—a sheet material primarily composed of one or more synthetic polymers for use as a secondary water-shedding layer on steep sloped roofs when installed below the primary roof covering.

3.2.1.1 *Discussion*—Examples include polyethylene, polypropylene, or polyethylene terephthalate.

4. Workmanship, Finish, and Appearance

4.1 The polymeric roof underlayment shall be supplied in roll form.

4.2 The polymeric roof underlayment shall be uniform in thickness and appearance. It shall be free of visible defects

such as holes, ragged or untrue edges, breaks, cracks, tears, and protruding edges of reinforcement.

4.3 The surface of the underlayment sheet shall be designed to provide traction and slip resistance to the applicator.

NOTE 1—The intent of 4.3 is to recognize that surface slipperiness is important when working on a roof and, while no test method is specified in this standard, several methods for assessing the relative slipperiness of surfaces are available. It is the further intent of this paragraph to ensure that, whatever method is used, the friction coefficient or resistance to slipping of the surface of these products should be at least as great as asphalt-saturated felt shingle underlayment tested under the same conditions of temperature and wetness as agreed between purchaser and seller.

5. Physical Requirements

5.1 The polymeric roof underlayment shall conform to the physical requirements prescribed in [Table 1](#).

6. Sampling

6.1 The samples to be tested for conformance to this specification shall be taken directly from rolls randomly selected in accordance with Test Methods [D146/D146M](#).

6.2 The specimens shall be cut from the selected roll so that no specimen is taken from a portion of the roll that exhibits damage from handling or prolonged exposure to light.

7. Test Methods

7.1 *Conditioning*—Unless otherwise stated, all specimens to be tested shall be conditioned for a minimum period of 24 h at 23 ± 2 °C [73 ± 4 °F] and 50 ± 10 % relative humidity (RH) prior to testing.

NOTE 2—The positive and negative variations specified, along with the temperature and relative humidity settings, are the maximum allowed operational fluctuations from the set points specified under equilibrium conditions. They do not imply that the set points can be higher or lower than those specified.

7.2 *Unrolling*—The polymeric roof underlayment shall not crack nor be so sticky as to cause tearing, delamination, or other damage upon being unrolled at temperatures between 0 and 60 °C [32 and 140 °F]. A finished roll shall be conditioned at each of the aforementioned temperatures for 24 h, and then unrolled within 5 min (± 1 min) at laboratory conditions.

7.3 *Pliability*—Ten 25.4 mm by 203 mm [1 in. by 8 in.] specimens, five taken in the machine direction and five taken in the cross-machine direction, are maintained at -10 ± 2 °C [14 ± 4 °F] for a minimum of 24 h and the exposed surface is bent over a 3.2 mm [$1/8$ in.] diameter steel mandrel through a 90° angle. Complete the entire procedure inside the refrigerated unit, including bending over the mandrel, within 2 ± 1 s.

TABLE 1 Requirements for Polymeric Roof Underlayments

Test Requirement	Specimen Type	Test Method	Conditions of Acceptance
Unrolling	As received	7.2	No visible cracking, tearing, or delamination of underlayment
Pliability	As received	7.3	No visible cracking or delamination of underlayment
Water Vapor Transmission	As received	7.4	Results shall be reported in Perms
Liquid Water Transmission	As received	7.5	Shall meet the "PASS" requirements of ASTM D4869/D4869M
Linear Dimensional Change	As received	7.6	Max. linear change of -2.5 to $+1$ %
Tensile Strength (machine and cross-machine direction)	As received After Thermal Cycling After Laboratory Accelerated Weathering	7.7 7.7 and 7.11 7.7 and 7.12	Min. 3.5 kN/m [20 lbf/in.]
Tearing Strength (machine and cross-machine direction)	As received After Thermal Cycling After Laboratory Accelerated Weathering	7.8 7.8 and 7.11 7.8 and 7.12	Min. 67 N [15 lbf]
Fastener Pull-Through Resistance	As received After Thermal Cycling After Laboratory Accelerated Weathering	7.9 7.9 and 7.11 7.9 and 7.12	Min. 111 N [25 lbf]
Hydrostatic Resistance	As received After Thermal Cycling After Laboratory Accelerated Weathering	7.10 7.10 and 7.11 7.10 and 7.12	No water shall pass through any specimen
Thermal Cycling	As received	7.11	No visible damage such as peeling, chipping, crazing, splitting, cracking, flaking, or pitting
Laboratory Accelerated Weathering ^A	As received	7.12	No visible damage such as peeling, chipping, crazing, splitting, cracking, flaking, or pitting

^A The effect of laboratory accelerated weathering on the tensile strength, tearing strength, fastener pull-through resistance, and hydrostatic resistance of the roof underlayment is for the purpose of simulating the effect of solar radiation, heat, and moisture on the roof underlayment during the period in which it is exposed to the environment before the roof covering is installed.

7.4 *Water Vapor Transmission*—The test shall be conducted in accordance with Test Methods E96/E96M, using the Water Method, Procedure B.

7.5 *Liquid Water Transmission*—The test shall be conducted in accordance with the Liquid Water Transmission section of Specification D4869/D4869M.

7.6 *Linear Dimensional Change*—Specimens shall be prepared and tested following the methods specified in Test Method D1204 at a temperature of $85 \pm 1 \text{ }^\circ\text{C}$ [$185 \pm 2 \text{ }^\circ\text{F}$] for a period of 24 h.

NOTE 3—Per Test Method D1204, the percentage linear change in both the machine and cross-machine direction shall be measured and averaged. The largest percentage linear change in either direction shall be reported.

7.7 *Tensile Strength*—The test shall be conducted in accordance with Test Method D5035 using the Cut Strip Method, with the following exception:

7.7.1 Prepare five specimens in both the machine and cross-machine direction from each of the as-received, post-thermal cycling, and post-laboratory accelerated aged specimens. Specimens shall be Type 1C-E as described in Test Method D5035. Testing shall be done on as-received, after thermally cycled, and after laboratory accelerated weathered specimens.

7.8 *Tearing Strength*—The test shall be conducted in accordance with Test Method D4533/D4533M, with the following exception:

7.8.1 Prepare five specimens in both the machine and cross-machine direction from each of the as-received, post-thermal cycling, and post-laboratory accelerated aged specimens for testing in the dry condition only. Testing shall be done on as-received, after thermally cycled, and after laboratory accelerated weathered specimens.

7.9 *Fastener Pull-Through Resistance*—A minimum of ten specimens each from as-received, post-thermal cycling, and post-laboratory accelerated aged specimens shall be prepared and tested following the methods specified in the Fastener Pull-Through Resistance section of Test Methods D228/D228M, with the following exceptions:

7.9.1 Fastener shall be a standard galvanized roofing nail, minimum 37 mm [$1\frac{1}{2}$ in.] long, having a 9.5 mm [$\frac{3}{8}$ in.] diameter head (ASTM F1667 NL RF S S-36Z; see Specification F1667, Table 29). See Note 4.

7.9.2 The specimen shall be secured between the base and plate using four bolts which are tightened sufficiently to prevent specimen slippage during the test. Refer to Figs. 1 and 2 for further mounting details. Testing shall be done on as-received, after thermally cycled, and after laboratory accelerated weathered specimens.

NOTE 4—This test procedure is designed to provide a measurement of the pull-through resistance of polymeric roof underlayment using a defined nail head under defined conditions. It is not intended to represent product application conditions but is intended to provide an assessment of the pull-through resistance of the product required for compliance to this specification.

7.10 *Hydrostatic Resistance*—The test shall be conducted in accordance with Test Methods D751, Procedure A, Procedure 2 with the following exceptions:

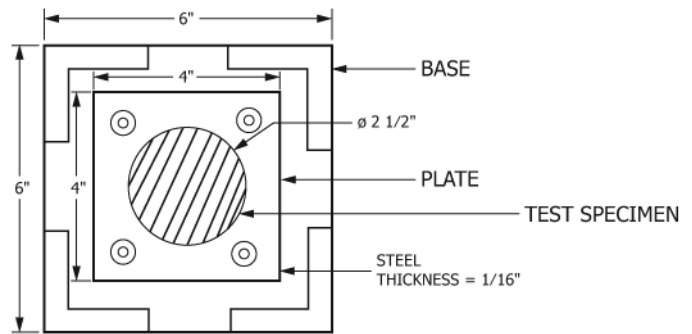

FIG. 1 Base and Plate Parts of Apparatus

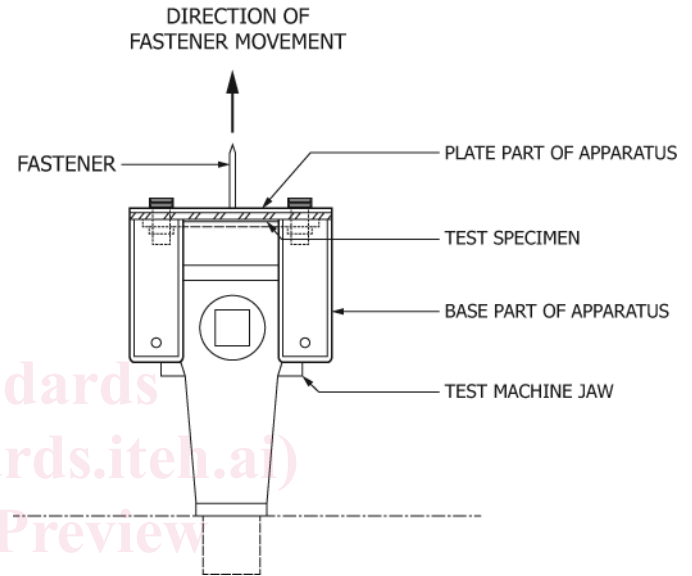

FIG. 2 Apparatus

7.10.1 The Mullen-type tester shall be equipped with a pressure gauge that is graduated in units no greater than 0.1 psi. Prepare five specimens from each of the as-received, post-thermal cycling, and post-laboratory accelerated weathered specimens. Testing shall be done on as-received, after thermally cycled, and after laboratory accelerated weathered specimens.

7.10.2 The exposed side of the test specimen shall be placed on the bottom clamp and a pressure of $7 \pm 1 \text{ kPa}$ [$1 \pm 0.1 \text{ psi}$] shall be maintained for the duration of the test.

7.11 *Thermal Cycling*—Expose sufficient material to thermal cycling to allow preparation of tensile strength, tearing strength, fastener pull-through resistance, and hydrostatic resistance specimens from the exposed material after ten cycles, with each cycle consisting of the following:

7.11.1 Oven drying at $50 \pm 1 \text{ }^\circ\text{C}$ [$120 \pm 2 \text{ }^\circ\text{F}$] for 8 h with all surfaces exposed.

7.11.2 Remove the material and within 5 min (± 1 min), begin conditioning it for 16 h at $-40 \pm 1 \text{ }^\circ\text{C}$ [$-40 \pm 2 \text{ }^\circ\text{F}$].

7.11.3 When not under the cycling conditions per 7.11.1 and 7.11.2, such as on weekends, the material shall be in the air-dry period, which shall be confirmed in the test log. The room temperature shall be maintained at $23 \pm 2 \text{ }^\circ\text{C}$ [$73 \pm 4 \text{ }^\circ\text{F}$] and $50 \pm 10 \text{ } \%$ RH.