



Designation: F2663 – 21a

Standard Test Method for Bead Unseating of Tubeless Passenger and Light Truck Tires¹

This standard is issued under the fixed designation F2663; the number immediately following the designation indicates the year of original adoption or, in the case of revision, the year of last revision. A number in parentheses indicates the year of last reapproval. A superscript epsilon (ϵ) indicates an editorial change since the last revision or reapproval.

1. Scope

1.1 This test method covers the static non-rolling laboratory method of determination of a tubeless tire's resistance to bead unseating. The test requires the use of a standardized fixture and load machine. The test is conducted using a defined test pressure and method of determining the resultant force to unseat the tire from the rim.

1.2 This test method is applicable for all passenger, light truck, and temporary spare tires.

1.3 The values stated in SI units are to be regarded as standard. The values given in parentheses are for information only.

1.4 *This standard does not purport to address all of the safety concerns, if any, associated with its use. It is the responsibility of the user of this standard to establish appropriate safety, health, and environmental practices and determine the applicability of regulatory limitations prior to use.*

1.5 *This international standard was developed in accordance with internationally recognized principles on standardization established in the Decision on Principles for the Development of International Standards, Guides and Recommendations issued by the World Trade Organization Technical Barriers to Trade (TBT) Committee.*

2. Referenced Documents

2.1 *ASTM Standards:*²

F538 Terminology Relating to Characteristics and Performance of Tires

F1502 Test Method for Static Measurements on Tires for Passenger Cars, Light Trucks, and Medium Duty Vehicles

¹ This test method is under the jurisdiction of ASTM Committee F09 on Tires and is the direct responsibility of Subcommittee F09.30 on Laboratory (Non-Vehicular) Testing.

Current edition approved Sept. 1, 2021. Published February 2022. Originally approved in 2007. Last previous edition approved in 2021 as F2663 – 21. DOI: 10.1520/F2663-21A.

² For referenced ASTM standards, visit the ASTM website, www.astm.org, or contact ASTM Customer Service at service@astm.org. For *Annual Book of ASTM Standards* volume information, refer to the standard's Document Summary page on the ASTM website.

3. Terminology

3.1 *Definitions:*

3.1.1 *bead, of a tire, n*—part of a tire that comes in contact with the rim and is shaped to secure the tire to the rim. **F538**

3.1.2 *bead unseating block, n*—machined block of cast aluminum (also known as “shoe”) used on the bead unseating fixture to press against the tire sidewall. **F538**

3.1.3 *manufacturer, n—of a tire*, the name of a company or wholly owned subsidiary making the tire. **F538**

3.1.4 *measuring rim, n*—any ‘rim’ with a width as specified for the design or measuring rim for a particular tire size designation, and with the ‘bead’ seat and flange dimensions in accordance with publications of tire and rim standards organizations current at the time of manufacture. **F538**

3.1.5 *outside diameter, n*—the maximum diameter of a tire when it is mounted and inflated. **F538**

3.1.6 *overall width, n*—the maximum cross-sectional width of a tire, including protective or decorative ribs. **F538**

3.1.7 *rim, n*—the specially shaped circular periphery to which a tire may be mounted with appropriate bead fitment. **F538**

3.1.8 *rim, test, n*—a rim having the configuration and dimensions suitable for use with a test tire in accordance with publications of a tire and rim standards organization current at the time of tire manufacture. **F538**

3.1.9 *sidewall, of a tire, n*—that portion of a tire between the tread and the bead. **F538**

3.1.10 *specified design section width, n*—the width specified in the publications of tire and rim standards organizations current at the time of manufacture for a new tire of that size designation and type when inflated on its “measuring rim.” **F538**

3.1.11 *tire, light truck, n*—a tire of a group prescribed in “Light Truck” or “Commercial” tire sections of industry standards manuals such as The European Tyre and Rim Technical Organisation (ETRTO), Japan Automobile Tyre Manufacturers Association (JATMA), and The Tire and Rim Association (TRA). The tire will typically have either “LT” or “C” (C-type) as part of the tire size designation.

3.1.11.1 *Discussion*—An LT tire is a light truck tire with the letters “LT” either as a prefix or suffix of the tire size nomenclature. These tires are typically standardized by JATMA or TRA. A C-type tire is a light truck (commercial) tire with the letter “C” as a suffix to the tire size nomenclature. These tires are standardized by ETRTO, and located in the “Commercial” tire section of the Standards Manual.

3.1.12 *tire, passenger car, n*—a tire of a group prescribed in a passenger tire section of industry standards manuals such as The European Tyre and Rim Technical Organisation (ETRTO), Japan Automobile Tyre Manufacturers Association (JATMA), or The Tire and Rim Association (TRA).

3.1.13 *tire, pneumatic, n*—a hollow tire that becomes load-bearing upon inflation with air, or other gas, to a pressure above atmospheric. **F538**

3.1.14 *tread, of a tire, n*—the part of the tire that comes in contact with the ground. **F538**

3.1.15 *unseating, v*—the dislodgment of the bead area of a tire from the portion of the rim designed to hold the bead in place resulting in loss of inflation pressure. **F538**

3.1.16 *wheel, n*—a rigid structure consisting of a rim connected to a central disk that permits rotationally centered attachment to an axle. **F538**

4. Summary of Test Method

4.1 This test method measures the force needed to unseat a tire from a clean, dry, painted test rim/wheel. The force is applied through a specified bead unseating block and pivoting load arm set substantially parallel to the tire rim/wheel assembly at the start of the test. The force is measured at a specific point of the fixture. The point to be contacted on the tire sidewall is determined within this test method.

5. Significance and Use

5.1 This test method establishes a standard procedure for the test and provides data that can be related to the force required to unseat the bead of a tire inflated with a specified pressure from the rim. This test method does not establish performance limits or tolerances for tire specifications.

6. Apparatus

6.1 A fixture to hold the tire-rim/wheel assembly as shown in **Annex A1** or equivalent.

6.2 Testing machine which incorporates a block traveling at 50.8 ± 1.6 mm/min (2.0 ± 0.0625 in./min) which can exert a force on the fixture at the spherical attachment point (in line with the centerline of the bead unseating block) or equivalent.

6.3 A force indicating device that shall have an accuracy of ± 1 % of the indicated force in the operating range and shall reflect an instantaneous change in force from zero to full scale in no more than 3.0 s.

6.4 Means for calibration of the testing machine for applied load and rate of application speed are necessary.

6.5 Means for mounting the tire on a test rim/wheel and mounting the test assembly on the testing machine is necessary.

6.6 Test rims/wheels.

6.7 Pressure gauge, capable of measuring the pressure within ± 3.5 kPa (0.5 psi).

7. Sampling

7.1 A sample is one or more tires taken from a lot as directed in any applicable specification, or as taken from a shipping unit, or as agreed upon between the purchaser and the seller.

7.2 Record the manufacturer’s identification, brand name, tire identification number, tire outside diameter, rim/wheel diameter code and width, tire size, tire load identification information (including, as appropriate: load range, load index, standard load, extra load, light load, etc.), and type of tire. Visually inspect the tire completely for excessive mold lubricant and any obvious faults or conditions that could affect the test.

8. Preparation of Apparatus

8.1 Check fixture for bent arm, loose or binding pivot and flat seating of rim/wheel on the support flange.

8.2 On certain equipment designs, check alignment of spherical adaptor and ram from load machine.

9. Calibration and Standardization

9.1 Calibration standards shall be comprised of instrumentation and measuring apparatus that are used for verification of the accuracies of the indicating-recording instruments, pressure setting and travel speeds. Calibration standard accuracy will be ascertained by comparison of the standard with primary standards maintained by the National Institute of Standards and Technology (NIST) or secondary standards traceable to NIST or applicable national standards. The frequency of calibration shall be as often as necessary to ensure that all functions are within tolerances listed in Section 6.

10. Conditioning

10.1 The ambient temperature for tire conditioning and in the test area shall be any known temperature within the range of $24 \pm 8^\circ\text{C}$ ($75 \pm 15^\circ\text{F}$) (see Test Method **F1502**).

11. Procedure

11.1 The tire must be at room temperature before mounting. Wash the tire, dry the bead area and mount the tire on a dry, clean, corrosion free test rim/wheel without lubrication or adhesives.

11.2 Inflate the tire to, but do not exceed, the maximum inflation pressure indicated on the tire sidewall, to seat the bead. Verify proper bead seating.

11.3 Immediately reduce the pressure to the specified pressure based on the requirements of the bead unseat standard or **Table 1** or **Table 2**.

TABLE 1 Passenger Car Tire Inflation Pressure

NOTE 1—Conversions are based on historical precedents. See bibliography (1–9).

Tire Load Identification	Test Inflation kPa (psi)
Alphanumeric type tires	
Load range B	165 (24)
Load range C	195 (28)
Load range D	220 (32)
“Passenger” type tires	
Standard load, Light Load	180 (26)
Extra load	220 (32)
“T” type tires	
Temporary use	360 (52)

TABLE 2 Light Truck (LT) Tire Inflation Pressure

NOTE 1—Conversions are based on historical precedents. See bibliography (1, 6, and 7).

Tire Load Identification	Test Inflation kPa (psi)	Tire Load Range
“LT” and “C” type tires Cross section \leq 295 mm (11.5 in.)	260 (38)	LR C
	340 (49)	LR D
	410 (59)	LR E
“LT” and “C” type tires Cross section > 295 mm (11.5 in.)	190 (28)	LR C
	260 (38)	LR D
	340 (49)	LR E

NOTE 1—Certain kPa and psi pressure equivalencies in [Table 1](#) and [Table 2](#) are different based on their sources.

11.4 Condition the test assembly for 24 h at the ambient room temperature. The test assembly during conditioning or testing shall not be exposed to fluctuations in temperature exceeding +2.6°C, –5.8°C (+5°F, –10°F) of the starting conditioning temperature.

11.5 Readjust the pressure as required in [11.3](#), the inflation pressure tolerance shall be ± 3.5 kPa (0.5 psi).

11.6 Measure the overall and section widths of the tire at six points equally spaced around the tire and record the average of these measurements (see Test Method [F1502](#) or equivalent for details).

11.7 Measure the outside diameter of the tire by measuring the circumference and dividing by Pi (3.1416) or use of Diameter (Pi) Tape (see Test Method [F1502](#) or equivalent for details).

11.8 The tire shall be marked radially at 5 equally spaced locations on the valve side of the sidewall.

11.9 Mount the test assembly in the test fixture shown in [Annex A1](#).

11.10 Position the bead unseating block (2A, 2B, 2C) selected based on the table in [Annex A1](#) against the tire sidewall at the “A” distance determined by using the following calculation.

$$A = 0.75 \times [0.5(OD - RD)] + 0.5RD \quad (1)$$

where:

OD = tire outer diameter or nominal diameter from applicable standard

RD = nominal rim code

NOTE 2—The tolerance for the “A” dimension is ± 1.5 mm (0.06 in.).

11.11 Position the unseating block to touch the tire sidewall with a force less than 2.5 daN (5 lbf). Level the arm so that it is parallel, $\pm 2^\circ$, to the tire.

11.12 Check and, if necessary, readjust the inflation pressure.

11.13 Apply the load through the unseating block at a rate of 50.8 ± 1.6 mm/min (2.0 ± 0.0625 in./min) with the force measured through the block in a vertical direction at the center line of the beam until the bead unseats, air loss is audible (pressure is reduced), or limit from applicable standard is reached without the block contacting the rim. Record the maximum force. Depending on equipment design, subtract the (tare) weight of the load arm if not previously considered during setup or calibration.

11.14 If, during the application of load ([11.13](#)), the bead unseats, reinflate the tire to the maximum pressure indicated on the sidewall to reseat the bead, verify proper bead seating, and immediately reduce the pressure to the specified pressure based on the requirements of the bead unseat test pressure table.

11.15 Repeat 4 times at equally spaced locations around the tire (making total of 5 measurements).

12. Calculation or Interpretation of Results

12.1 Result is the least or minimum value obtained in [11.13](#).

13. Report

13.1 The report should include the following:

13.1.1 A title (for example, “Bead Unseat Test ASTM F2663”);

13.1.2 The name and address of the laboratory, and the location where the tests or calibrations, or both, were carried out, if different from the address of the laboratory;

13.1.3 Unique identification of the test report (such as report or request number), and number of report page and clear identification of report end. Name and address of client if different from company performing the test;

13.1.4 Date test is performed;

13.1.5 Date of calibration of the required equipment (optional);

13.1.6 Test results with, where appropriate, units of measurement;

13.1.7 Block used (2A, 2B, or 2C);

13.1.8 The name(s) of the persons conducting and authorizing the reported results;

13.1.9 Comments to describe deviations from the test method and information regarding test conditions, such as environmental conditions; and

13.1.10 Where appropriate and needed, opinions and interpretations of results.

14. Precision and Bias

14.1 The repeatability and reproducibility of this test method is being determined and will be available on or before January 1, 2026.

15. Keywords

15.1 bead unseating; load machine; standardized fixture; tubeless tires; unseating; unseating block

ANNEX

A1. FIXTURES AND SETTINGS

A1.1 See diagram of bead unseating fixture (geometry) in Fig. A1.1.

A1.2 See Table A1.1 for Recommended Blocks.

A1.3 See diagram of bead unseating block Type 2A³ in Fig. A1.2.

A1.4 See diagram of bead unseating block Type 2B⁴ in Fig. A1.3.

A1.5 See diagram of bead unseating block Type 2C⁴ in Fig. A1.4.

A1.6 See diagram of RJS machine bead unseating block adaptor Type 2B in Fig. A1.5.

A1.7 See diagram of RJS machine bead unseating block adaptor Type 2C in Fig. A1.6.

³ The sole sources of supply of the Type 2A blocks and fixturing known to the committee at this time is Rockhill Machining Industries, Inc. (3 Fourth St. N.W., Barberton, OH 44203, jkallas@rockhillmachiningindustries.com) and RJS Corporation (3400 Massillon Rd., Akron, Ohio 44312, sales@rjscorp.com). If you are aware of alternative suppliers, please provide this information to ASTM International Headquarters. Your comments will receive careful consideration at a meeting of the responsible technical committee,¹ which you may attend.

⁴ The sole source of supply of the Type 2B and 2C blocks and fixturing known to the committee at this time is Rockhill Machining Industries, Inc., 21 Fourth St. N.W., Barberton, OH 44203, jkallas@rockhillmachiningindustries.com. If you are aware of alternative suppliers, please provide this information to ASTM International Headquarters. Your comments will receive careful consideration at a meeting of the responsible technical committee,¹ which you may attend.

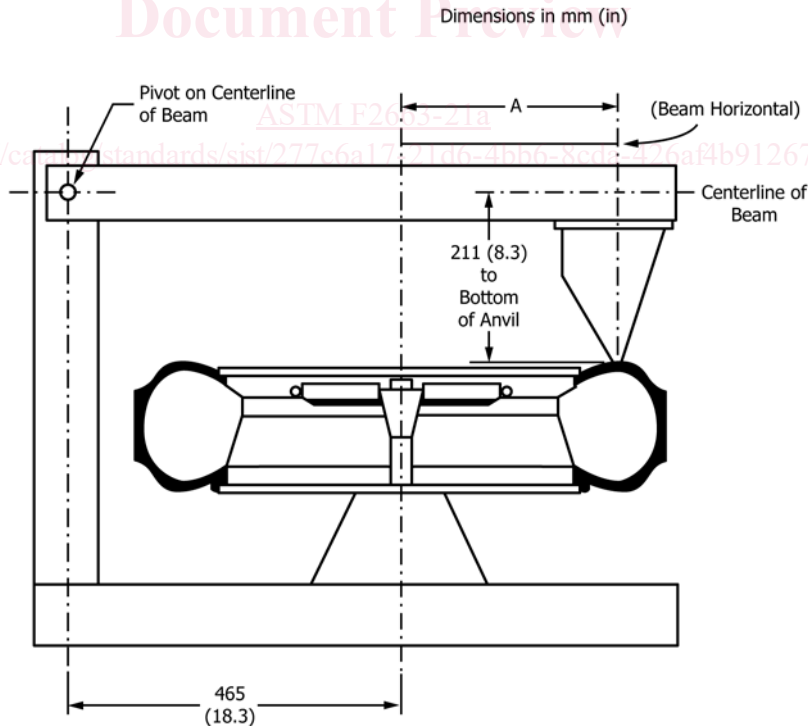

FIG. A1.1 Bead Unseating Fixture

TABLE A1.1 Table of Recommended Blocks and Rim Sizes

Recommended Block	Diameter Code	Rim Size	
			mm
2C	30		
2C	29		
2C	28		
2C	27		
2C	26		
2C	25		
2B	24		
2B	23		
2B	22		
2B	21		
2B	20		
2B	19		
2B	18		
2B	17		
2A	16		
2A	15		
2A	14		
2A	13		
2A	12		
2A	11		
2A	10		
2A			415
2A			390
2A			370
2A			365
2A			345
2A			340
2A			320
2A			315
2A			290

 (https://standards.itih.ai)
 Document Preview

[ASTM F2663-21a](#)

<https://standards.itih.ai/catalog/standards/sist/277c6a17-21d6-4bb6-8cda-426af4b91267/astm-f2663-21a>

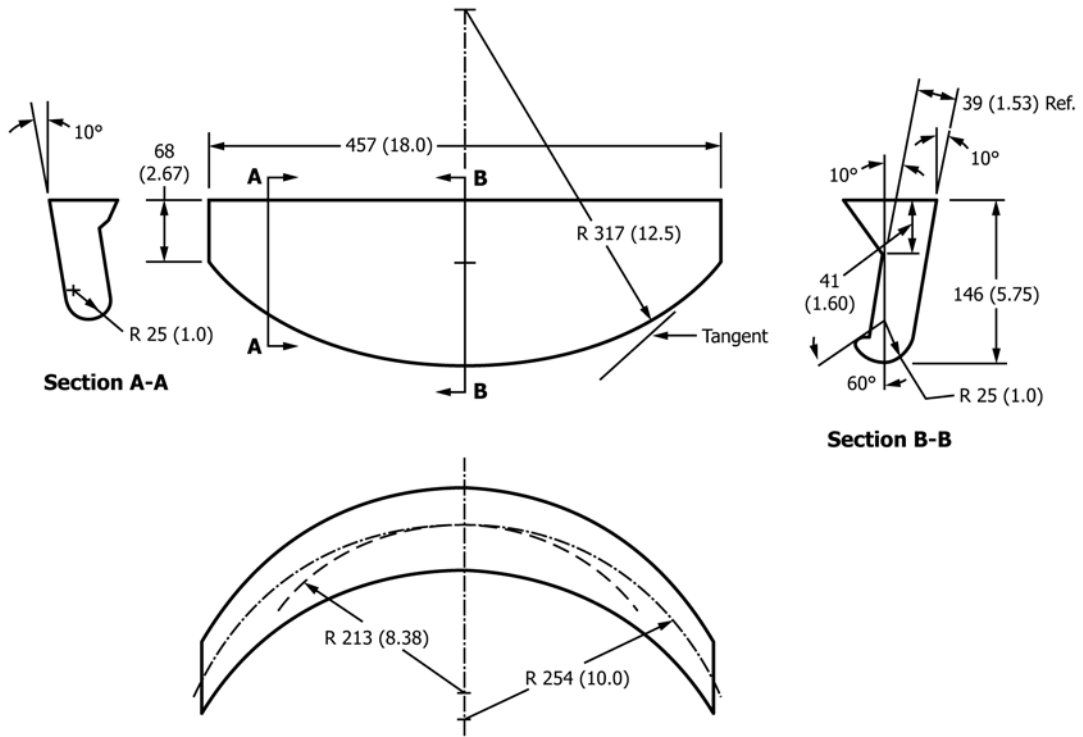

iTeh Standards

(<https://standards.itih.ai>)

Document Preview



NOTE 1—Material: cast aluminum 355 T-6 condition; Finish: 1.3 μm (50 μin.).

FIG. A1.2 Type 2A Bead Unseating Block

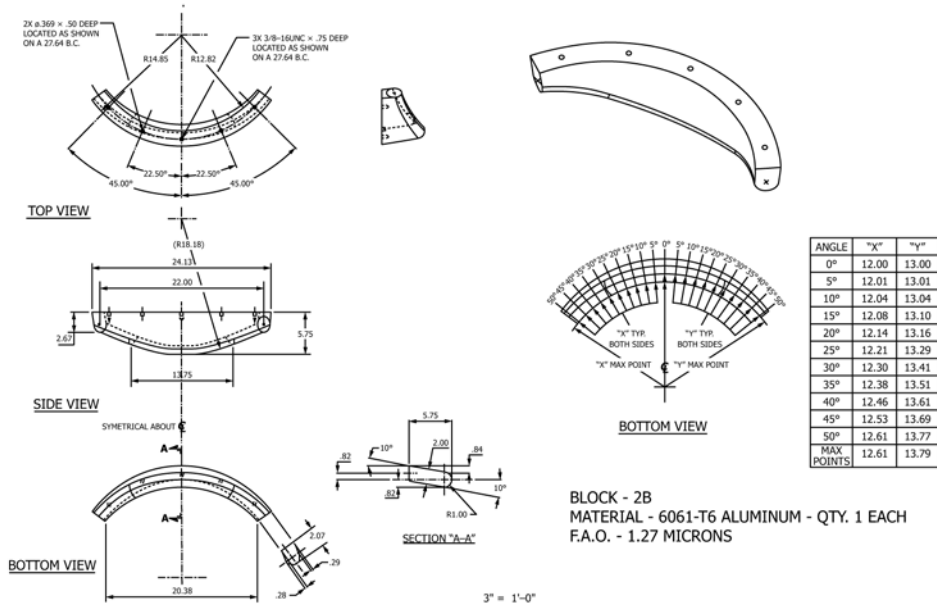

FIG. A1.3 Type 2B Bead Unseating Block and Adaptor

ASTM F2663-21a

<https://standards.iteh.ai/catalog/standards/sist/277c6a17-21d6-4bb6-8cda-426af4b91267/astm-f2663-21a>