



Designation: F521 – 22

Standard Test Methods for Bond Integrity of Transparent Laminates¹

This standard is issued under the fixed designation F521; the number immediately following the designation indicates the year of original adoption or, in the case of revision, the year of last revision. A number in parentheses indicates the year of last reappraisal. A superscript epsilon (ϵ) indicates an editorial change since the last revision or reappraisal.

1. Scope

1.1 These test methods cover determination of the bond integrity of transparent laminates. The laminates are usually made of two or more glass or hard plastic sheets held together by an elastomeric material. These test methods are intended to provide a means of determining the strength of the bond between the glass or plastic and the elastomeric interlayer under various mechanical or thermal loading conditions.

1.2 The test methods appear as follows:

| Test Methods | Sections |
|--|----------|
| Test Method A—Flatwise Bond Tensile Strength | 5 – 11 |
| Test Method B—Interlaminar Shear Strength | 12 – 17 |
| Test Method C—Creep Rupture | 18 – 25 |
| Test Method D—Thermal Exposure | 26 – 30 |

1.3 *This standard does not purport to address all of the safety concerns, if any, associated with its use. It is the responsibility of the user of this standard to establish appropriate safety, health, and environmental practices and determine the applicability of regulatory limitations prior to use.*

1.4 *This international standard was developed in accordance with internationally recognized principles on standardization established in the Decision on Principles for the Development of International Standards, Guides and Recommendations issued by the World Trade Organization Technical Barriers to Trade (TBT) Committee.*

2. Referenced Documents

2.1 *ASTM Standards:*²

D952 Test Method for Bond or Cohesive Strength of Sheet Plastics and Electrical Insulating Materials

2.2 *ANSI Standard:*³

B1.1 Standard for Unified Screw Threads

¹ These test methods are under the jurisdiction of ASTM Committee F07 on Aerospace and Aircraft and are the direct responsibility of Subcommittee F07.08 on Transparent Enclosures and Materials.

Current edition approved Feb. 1, 2022. Published February 2022. Originally approved in 1977. Last previous edition approved in 2016 as F521 – 16. DOI: 10.1520/F0521-22.

² For referenced ASTM standards, visit the ASTM website, www.astm.org, or contact ASTM Customer Service at service@astm.org. For *Annual Book of ASTM Standards* volume information, refer to the standard's Document Summary page on the ASTM website.

³ Available from American National Standards Institute (ANSI), 25 W. 43rd St., 4th Floor, New York, NY 10036, <http://www.ansi.org>.

3. Terminology

3.1 *Definitions:*

3.1.1 *delamination, n*—a visible separation between two layers of bonded material.

3.1.2 *face plies, n*—transparent glass or plastic outer materials joined together with an interlayer.

3.1.3 *interlayer, n*—transparent material used as the bonding agent between two or more hard, transparent materials.

3.2 *Definitions of Terms Specific to This Standard:*

3.2.1 *number of plies, n*—a three-ply laminate is one having two transparent glass or plastic plies and one interlayer ply; a five-ply laminate has three glass or plastic plies and two interlayer plies.

4. Significance and Use

4.1 These test methods provide a means to measure quantitatively the bond integrity between the outer layers of the transparency and the interlayer, or to measure the cohesive properties of the interlayer, under various loading conditions.

4.2 These test methods provide empirical results useful for control purposes, correlation with service results, and as quality control tests for acceptance of production parts.

4.3 Test results obtained on small, laboratory-size samples shown herein are indicative of full-size part capability, but not necessarily usable for design purposes.

TEST METHOD A—FLATWISE BOND TENSILE STRENGTH

5. Summary of Test Method

5.1 The bond is subjected to a mechanical load in a direction perpendicular to the plane of the bond. The adhesive or cohesive strength between the interlayer and the outer layers (flatwise tensile strength) is determined, and expressed in terms of pascals (or pounds-force per square inch).

6. Apparatus

6.1 *Metal Blocks*—A pair of 50 mm (2 in.) square metal blocks of 24 ST aluminum alloy, each having a maximum height of 50 mm (2 in.). Each block shall have in one end a hole (see Fig. 1) tapped 22.2 mm (7/8 in.) in accordance with ANSI B1.1, to accommodate threaded 22.2 mm (7/8-in.) studs

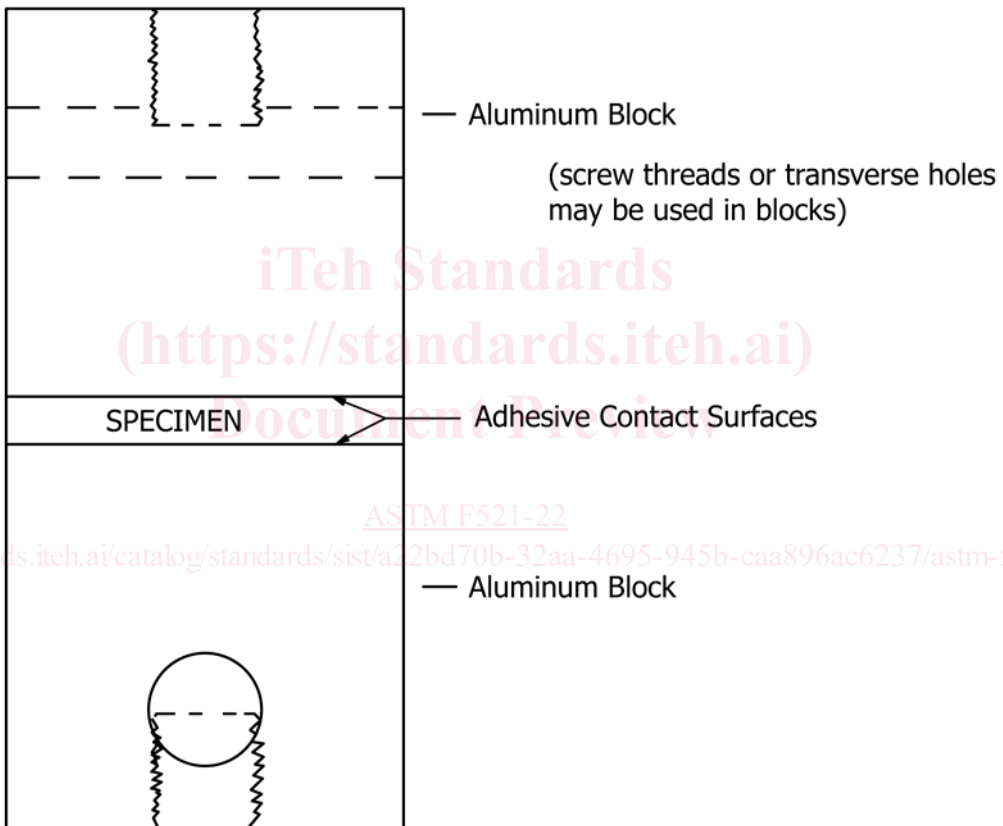
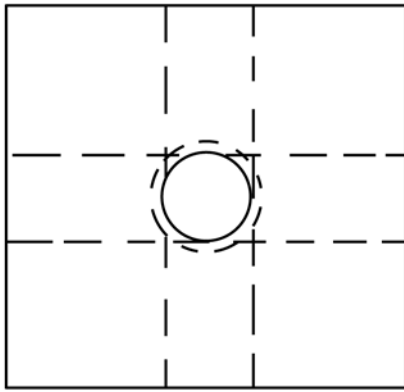

FIG. 1 Test Assembly for Flatwise Tensile Strength Test

of convenient length (see Test Method D952). Alternative metal blocks utilize an aluminum “T” section, cut to 50 mm (2 in.) square. A hole shall be drilled in the upright section of each “T” block (see Fig. 2) to accommodate a metal pin or holding device compatible with the test machine used.

6.2 *Testing Machine*—Any suitable machine of the constant-rate-of-crosshead movement type. The testing machine shall be equipped with the necessary drive mechanism for imparting to the crosshead a uniform, controlled velocity with respect to the base. The testing machine shall also be equipped with a load-indicating mechanism capable of showing the total load applied to the test specimen. This mechanism shall be essentially free from inertial-lag at the specified rate of testing and shall indicate the load with an accuracy of $\pm 1.0\%$ of the indicated value, or better.

6.3 *Adhesive*—Any suitable adhesive.⁴

⁴ Hysol Adhesive 907, a two-part epoxy adhesive available from E. V. Roberts Co., 9601 West Jefferson Blvd., Culver City, CA 90230, has been found satisfactory for use in this test. The instructions in Section 8 for preparation of the test assembly are based on the use of this material. Any adhesive that is found to perform satisfactorily under this test may be used, provided that the procedure for the preparation of the test assembly is suitably modified to follow the manufacturer’s recommendation for the use of the adhesive.

7. Test Specimen

7.1 The test specimen shall consist of a 50 mm (2 in.) square sample of laminate prepared in such a manner as to produce smooth edges to minimize the possibility of edge chipping during testing. The thickness of the specimen shall be the thickness of the laminate. The upper and lower surfaces shall be parallel to each other and reasonably flat. Test five specimens.

8. Preparation of Apparatus

8.1 Determine the cross-sectional area of the test specimen in a plane parallel to the surface.

8.2 Gently abrade the bonding surfaces of the metal blocks and the specimen (except glass—see Note 1) using 200–400 grit paper or light sandblasting. Do not abrade the edges and corners of the specimen or the metal blocks. Do not round the corners.

NOTE 1—Do not abrade glass surfaces unless absolutely necessary to obtain adhesion to the thoroughly cleaned surface.

8.3 Clean all contact surfaces of the specimens and metal or “T” blocks with a soft cloth saturated with a suitable solvent or clean dry air blast. Thereafter, do not touch the cleaned

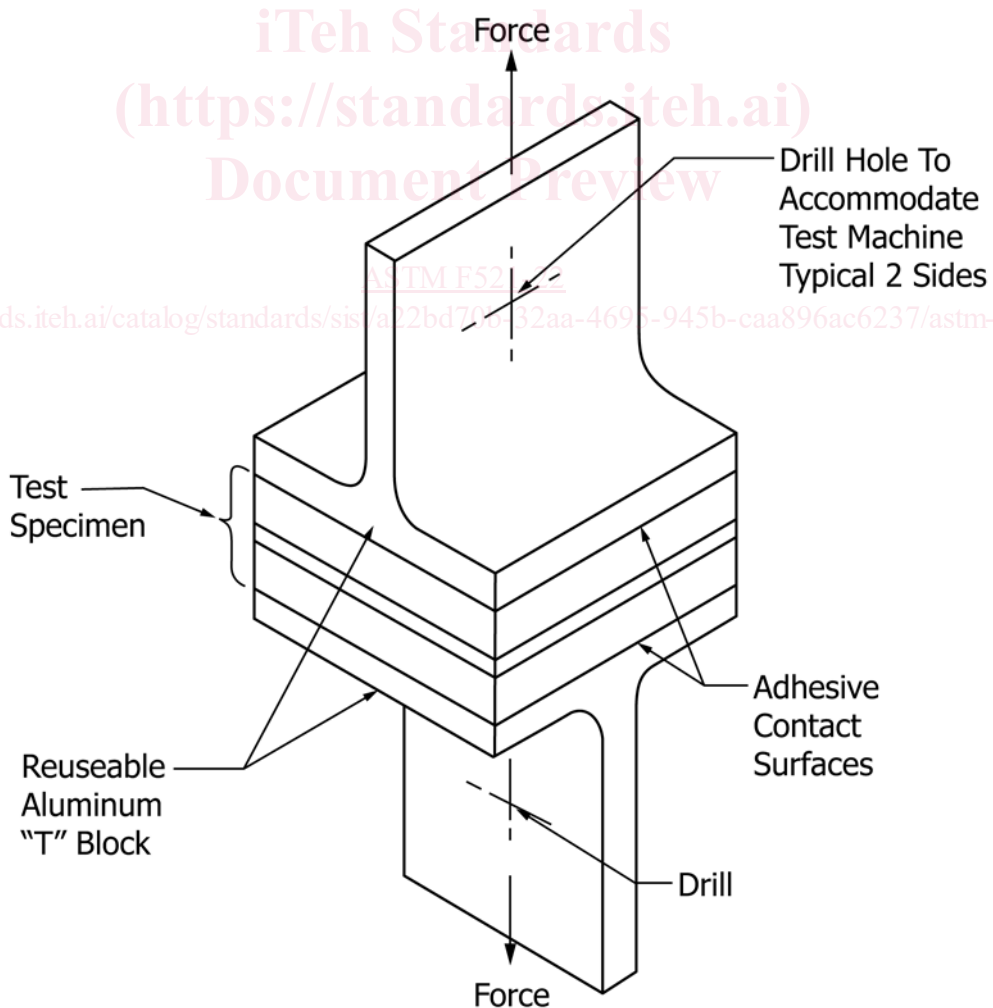

FIG. 2 Optional Tensile Strength Test Specimen

surfaces with the hands. Apply a thin coating of adhesive to both contact surfaces being careful to remove all air bubbles from the adhesive. Place the specimen between the coated blocks, being certain the blocks are aligned, then clamp the assembly until the adhesive is cured.

9. Conditioning

9.1 Condition the test specimen at $23 \pm 2^\circ\text{C}$ ($73.4 \pm 3.6^\circ\text{F}$) and $50 \pm 5\%$ relative humidity for not less than 24 h prior to testing.

9.2 Conduct tests in the Standard Laboratory Atmosphere of $23 \pm 2^\circ\text{C}$ ($73.4 \pm 3.6^\circ\text{F}$) and $50 \pm 5\%$ relative humidity, unless otherwise specified.

10. Procedure

10.1 Unless otherwise specified, test five specimens. Insert the specimen assembly in the tension testing machine with self-aligning holders and load to failure at a rate of 1.25 mm (0.05 in.)/min.

10.2 If block adhesive failure occurs, discard the test and test another specimen.

NOTE 2—This retest is only required if failure strength of the interlayer is required. If the test is being used to meet some minimum failure strength requirement and the specimen exceeds this value with a block adhesive failure, additional testing is not required. The location and failure mode shall be documented as required in 11.1.6.

NOTE 3—If aluminum blocks are to be reused, one method of removing the adhesive is to insert the blocks in an oven at 150°C (300°F) for 1.5 h. When the blocks have cooled, the remaining portion of the test specimen is easily removed by a surface sanding wheel or sandblast. In order to maintain a plane surface, it is recommended that the metal blocks be finished on a flat emery surface.

11. Report

11.1 The report shall include the following:

11.1.1 Complete identification of the material tested, including type or grade of substrate and interlayer, thickness, manufacturing history, and so forth,

11.1.2 The block adhesive used,

11.1.3 The atmospheric conditions in the test room,

11.1.4 The total load, in newtons (or pounds-force), required to break each specimen,

11.1.5 The unit stress, in pascals (or pounds-force per square inch), required for failure (calculate the unit stress by dividing the load by the area of the test specimen), and

11.1.6 Failure mode (such as within the interlayer, or at which interface).

TEST METHOD B—INTERLAMINAR SHEAR STRENGTH

12. Summary of Test Method

12.1 The bond is subjected to mechanical load in the direction of the plane of the interlayer. The maximum adhesive or cohesive strength between the interlayer and the outer plies (shear strength) is determined, and is expressed in pascals (or pounds-force per square inch).

13. Apparatus

13.1 *Shear Tool*—A shear test fixture of the sliding type which is so constructed that the specimen faces are firmly supported between the stationary and movable blocks to minimize peel effects. Suitable forms of shear tools are shown in Figs. 3 and 4, depending on specimen type.

13.2 *Testing Machine*—See 6.2.

14. Test Specimen

14.1 The test specimens shall be either three-ply or five-ply construction as shown in Figs. 5 and 6. The five-ply construction is preferred, especially for specimens with relatively thick interlayers of 2.5 mm (0.1 in.) or more.

14.2 The test specimen shall be 50 mm (2 in.) square minimum. Increasing specimen size will give slightly better accuracy up to the point where the face plies begin to fracture. Prepare the specimens in such a manner as to produce smooth edges to minimize premature edge chipping during testing.

14.3 Orient the samples to duplicate the actual loading conditions in service whenever possible.

14.4 *Number of Test Specimens:*

14.4.1 Test at least five specimens for each sample in the case of isotropic materials.

14.4.2 Test ten specimens, five normal to, and five parallel with the principal axis of anisotropy, for each sample of anisotropic material.

14.4.3 Discard specimens that break at some obvious flaw and retest, unless such flaws constitute a variable whose effect is desired for study.

15. Conditioning

15.1 Condition the specimens in accordance with Section 9.

16. Procedure

16.1 Measure and record the length and width of the bond area with a suitable micrometer to the nearest 0.025 mm (0.001 in.).

16.2 Place the specimen in the test fixture, taking care to align the loaded end of the specimen parallel to the loading bar.

16.3 Set the speed of testing at 1.25 mm (0.05 in.)/min and start the testing machine.

16.4 Record the maximum load carried by the specimen up to the point of rupture.

16.5 Remove and examine the test specimen for evidence of premature failure due to edge chipping or slippage of the specimen in the fixture. If premature failure has occurred, discard the sample and retest another sample.

16.6 Calculate the bond stress by dividing the maximum load by the bond area. For three-ply tests, the bond area is the area of one of the bond-line surfaces; for five-ply tests, the area is two times the area of one of the bond-line surfaces.

17. Report

17.1 The report shall include the following:

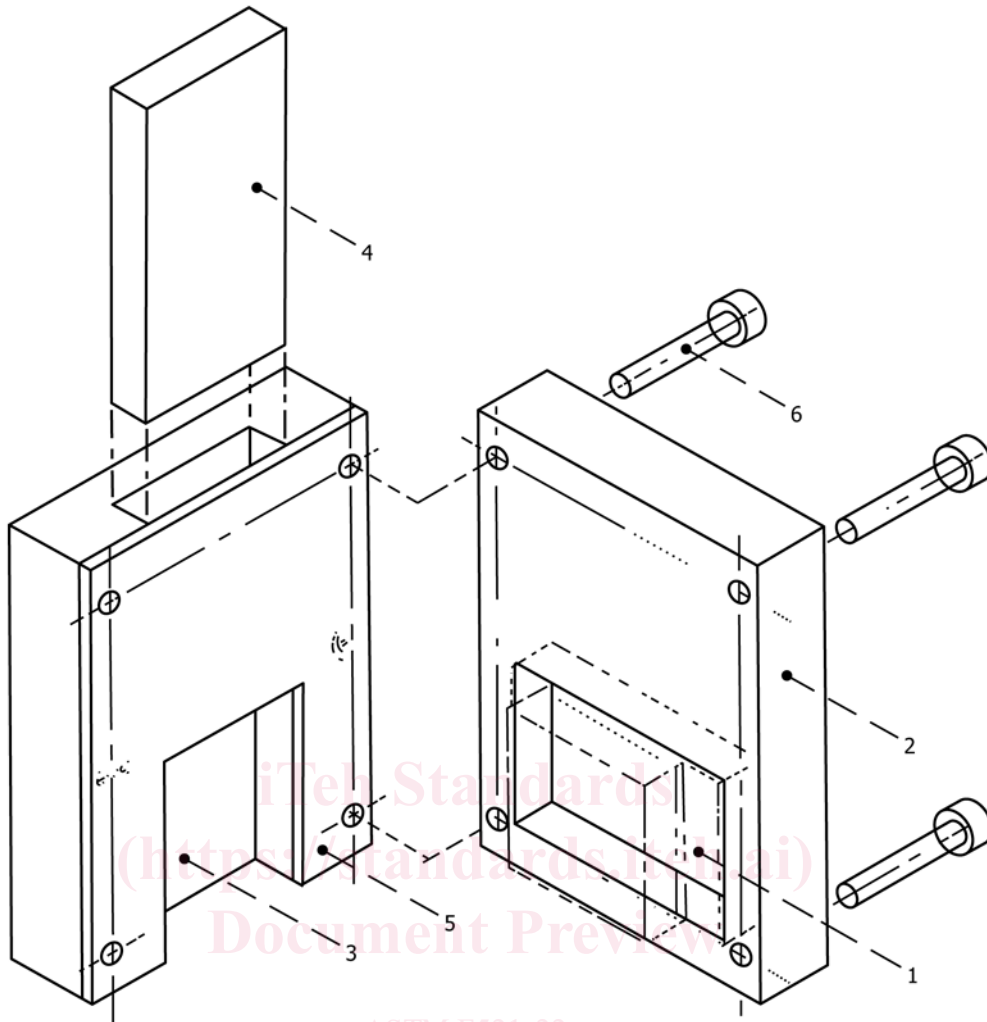

1. Three-ply shear test specimen.
2. Female steel housing.
3. Male steel housing.
4. Loading bar (hardened steel).
5. Shim (same thickness as the interlayer).
6. Bolts.

FIG. 3 Three-Ply Shear Test Fixture

17.1.1 Complete identification of the material tested, including type, source, manufacturer's code number, configuration principal dimensions, and previous history,

17.1.2 The size of the specimen and direction of loading,

17.1.3 The conditioning procedure,

17.1.4 The total load, in newtons (or pounds-force), required to break each specimen,

17.1.5 The bond shear stress, in pascals (or pounds-force per square inch), and

17.1.6 Failure mode (such as within the interlayer or at which interface).

TEST METHOD C—CREEP RUPTURE

18. Summary of Test Method

18.1 The bond is subjected to a specified duration of load application under a variety of environmental conditions. The time to failure or mode of failure, with a given load, is determined.

19. Significance and Use

19.1 Data from creep tests are of considerable importance in predicting the performance of materials with variations of design or interlayer materials. Variations include elevated or