INTERNATIONAL STANDARD



5169

INTERNATIONAL ORGANIZATION FOR STANDARDIZATION • МЕЖДУНАРОДНАЯ ОРГАНИЗАЦИЯ ПО СТАНДАРТИЗАЦИИ • ORGANISATION INTERNATIONALE DE NORMALISATION

Machine tools — Presentation of lubrication instructions

Machines-outils — Présentation des instructions pour la lubrification

First edition — 1977-05-01

ITeH STANDARD PREVIEW
(standards.iteh.ai)

[ISO 5169:1977](https://standards.iteh.ai/catalog/standards/sist/e075fd2a-b260-43a5-8952-eddc2f6d968a/iso-5169-1977)

<https://standards.iteh.ai/catalog/standards/sist/e075fd2a-b260-43a5-8952-eddc2f6d968a/iso-5169-1977>

UDC 621.9-72 : 003.6

Ref. No. ISO 5169-1977 (E)

Descriptors : machine tools, lubrication, instructions, name plate.

FOREWORD

ISO (the International Organization for Standardization) is a worldwide federation of national standards institutes (ISO member bodies). The work of developing International Standards is carried out through ISO technical committees. Every member body interested in a subject for which a technical committee has been set up has the right to be represented on that committee. International organizations, governmental and non-governmental, in liaison with ISO, also take part in the work.

Draft International Standards adopted by the technical committees are circulated to the member bodies for approval before their acceptance as International Standards by the ISO Council.

International Standard ISO 5169 was developed by Technical Committee ISO/TC 39, *Machine tools*, and was circulated to the member bodies in March 1976.

It has been approved by the member bodies of the following countries :

Austria	Italy	South Africa, Rep. of
Belgium	Japan	Spain
Chile	Mexico	Sweden
Czechoslovakia	Netherlands	Switzerland
Germany	Philippines	Turkey
Hungary	Poland	United Kingdom
India	Romania	U.S.A.

The member body of the following country expressed disapproval of the document on technical grounds :

France

Machine tools – Presentation of lubrication instructions

1 SCOPE AND FIELD OF APPLICATION

This International Standard gives guidance to both manufacturers and users of machine tools on the information that should be provided and followed regarding the lubrication instructions.

2 REFERENCES

ISO 369, *Symbols for indications appearing on machine tools.*¹⁾

ISO 3498, *Lubricants for machine tools.*²⁾

3 DEFINITIONS

3.1 lubrication point: The point at which lubricant is fed in order to lubricate a bearing surface.

3.2 action point: Any point in a lubrication system where, in general, an external action should be carried out to ensure the correct operation of the system.

Examples: Filling with lubricant (nipples or reservoirs, etc.), actuation of a lever, etc.

4 TECHNICAL DOCUMENTATION

4.1 Lubrication instructions

All information concerning the lubrication of the machine tool should be contained in a single document called "Lubrication instructions" which shall be compiled by the machine tool manufacturer.

The "Lubrication instructions" may form part of the general instruction manual.

4.2 Technical data to be included in the lubrication instructions

Lubrication instructions shall indicate the following:

4.2.1 The designation of machine components to be lubricated.

4.2.2 The exact location of all action points.

4.2.3 The type of action to be performed (inspection, replenishing, cleaning, lubricant change, actuation of a lever, etc.).

4.2.4 The designation of the lubricants to be used according to ISO standards and the capacity of the reservoirs.

4.2.5 The time interval in machine tool running hours at which each action point requires attention.

4.3 Schematic representation of lubrication instructions

The instructions listed in 4.2 shall be illustrated by means of diagrams, photographs or schematic views. Care should be taken to avoid those details which could lead to misunderstanding, by keeping the illustrations as simple as possible.

A copy of the above-mentioned illustrations shall be available on the machine.

4.4 Lubrication instructions facsimile

The annex to this International Standard gives an example of lubrication instructions for a particular machine tool and shall be followed as regards layout. All symbols used in the lubrication instructions shall, where available, comply with ISO 369.

4.5 Minimum requirements

The basic information contained in the annex is the minimum necessary to comply with 4.2.

5 DATA PLATES TO BE USED ON THE MACHINE

5.1 Recommended plates

It is recommended that wherever practicable a single plate complying with the requirements of clause 4 be permanently attached to the machine.

At the option of the user, small data plates may be attached to each action point.

1) In preparation (revision of ISO/R 369-1964).

2) At present at the stage of draft. (Revision of ISO/TR 3498-1974.)

5.2 Small data plates for individual action points

If these small plates are to be used on the machine, they shall be rigidly fixed close to the action points, and shall be located so as not to be confused with other points. They shall indicate lubrication instructions only.

5.2.1 Technical data to be indicated on the plates

Letters and numbers shall be easily readable.

The colour should preferably be yellow, with the figures in black. Small data plates should indicate the following :

5.2.1.1 Action point number.

5.2.1.2 Symbol of the action to be performed, according to ISO 369.

5.2.1.3 Designation of the lubricant to be used, according to ISO 3498.

5.2.1.4 Symbol of the time interval, in machine running hours, according to ISO 369.

5.2.2 Shape and sizes of small data plates

Small data plates should be square and, as an example, of 40 mm side.

5.2.3 Small data plate facsimile

See the examples below.

6 LUBRICATION TIME INTERVALS

The lubrication time intervals shall be supplied by the machine tool manufacturer in machine running hours.

The user should determine, from these, suitable intervals (for example : per shift, daily, weekly, monthly, etc.) for his particular utilization of the machine.

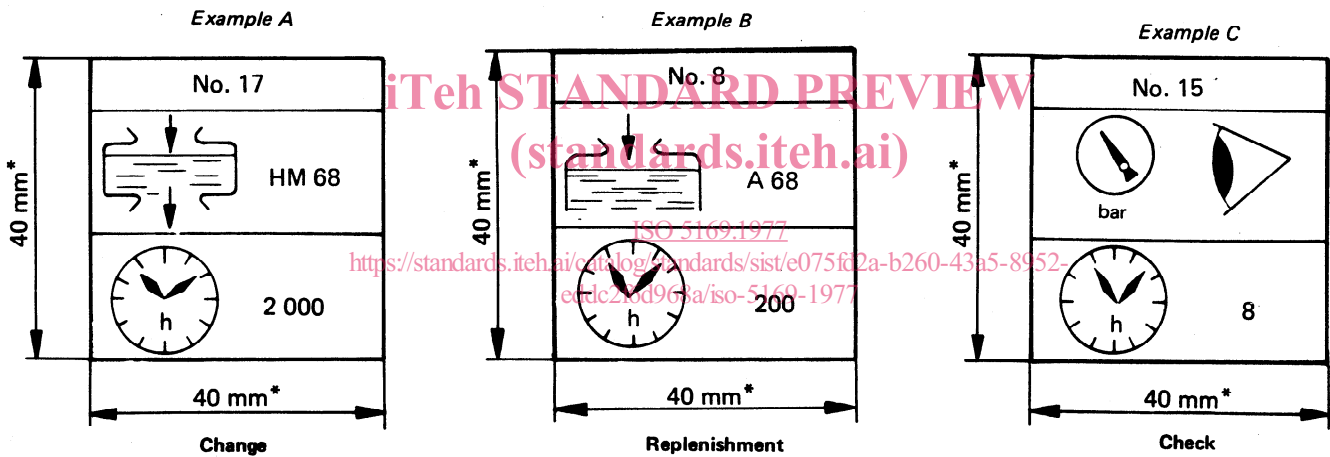

* Dimension given as an example.

ANNEX

EXAMPLE : CYLINDRICAL UNIVERSAL GRINDING MACHINE — MAKE : TYPE :

2 000
1 000
200
50
8



Running hours

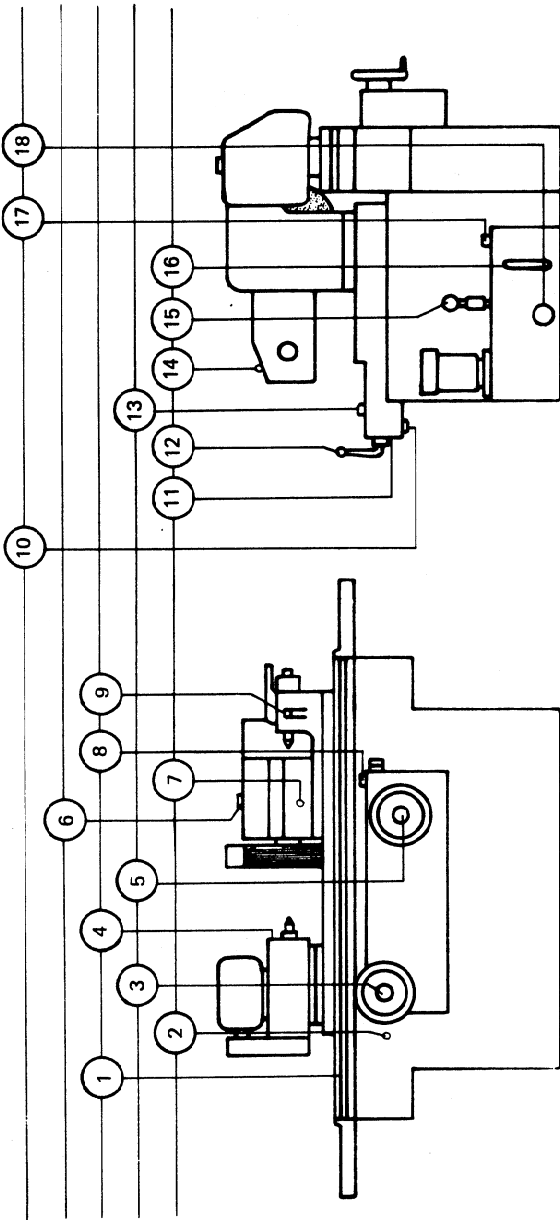

CAUTION, CLEAN ALL POINTS BEFORE LUBRICATING

Machine component	Table slideways	Table traverse mechanism	Work head spindle	Wheel feed system	Wheel spindle	Wheel fine feed system	Tail-stock	Wheelhead slideways	Internal grinding spindle	Hydraulic unit								
Action point No.	1	2	3	4	5	6	7	8	9	10	11	12	13	14	15	16	17	18
Nature of action																		
Check																		
Check and fill if necessary							8								8			
Operate																		
Replenish	200	50	50	200	50	1 000												
Clean or replace										2 000								2 000
Change																		
Lubricant designation*	G 68	A 68	A 68	XM 2	A 68	FD 10		G 68	FD 5									HM 68
Reservoir capacity (l)	2	0,3	0,3	0,1	0,3	1,5		4	0,1					0,2				75

* According to ISO 3498.

iTeh STANDARD PREVIEW
(standards.iteh.ai)

This page intentionally left blank

[ISO 5169:1977](#)

<https://standards.iteh.ai/catalog/standards/sist/e075fd2a-b260-43a5-8952-eddc2f6d968a/iso-5169-1977>

iTeh STANDARD PREVIEW
(standards.iteh.ai)

This page intentionally left blank

[ISO 5169:1977](#)

<https://standards.iteh.ai/catalog/standards/sist/e075fd2a-b260-43a5-8952-eddc2f6d968a/iso-5169-1977>

iTeh STANDARD PREVIEW

(standards.iteh.ai)
This page intentionally left blank

[ISO 5169:1977](#)

<https://standards.iteh.ai/catalog/standards/sist/e075fd2a-b260-43a5-8952-eddc2f6d968a/iso-5169-1977>