



Designation: **A574–17** **A574 – 21**

Standard Specification for Alloy Steel Socket-Head Cap Screws¹

This standard is issued under the fixed designation A574; the number immediately following the designation indicates the year of original adoption or, in the case of revision, the year of last revision. A number in parentheses indicates the year of last reapproval. A superscript epsilon (ε) indicates an editorial change since the last revision or reapproval.

This standard has been approved for use by agencies of the U.S. Department of Defense.

1. Scope*

1.1 This specification covers the requirements for quenched and tempered alloy steel hexagon socket-head cap screws, 0.060 through 4 in. in diameter where high strength is required.

1.2 The values stated in inch-pound units are to be regarded as standard. No other units of measurement are included in this standard.

1.3 The following hazard caveat pertains only to the test method portions, Sections 5.1, 5.6, 8, and 12, of this specification. *This standard does not purport to address all of the safety concerns, if any, associated with its use. It is the responsibility of the user of this standard to establish appropriate safety, health, and ~~health~~ environmental practices and determine the applicability of regulatory limitations prior to use.*

1.4 *This international standard was developed in accordance with internationally recognized principles on standardization established in the Decision on Principles for the Development of International Standards, Guides and Recommendations issued by the World Trade Organization Technical Barriers to Trade (TBT) Committee.*

2. Referenced Documents

[ASTM A574-21](https://standards.iteh.ai/catalog/standards/sist/5c30932f-dff4-4985-8819-618679da031e/astm-a574-21)

<https://standards.iteh.ai/catalog/standards/sist/5c30932f-dff4-4985-8819-618679da031e/astm-a574-21>

2.1 ASTM Standards:²

[A751 Test Methods and Practices for Chemical Analysis of Steel Products](#)

[E112 Test Methods for Determining Average Grain Size](#)

[F606/F606M Test Methods for Determining the Mechanical Properties of Externally and Internally Threaded Fasteners, Washers, Direct Tension Indicators, and Rivets](#)

[F788 Specification for Surface Discontinuities of Bolts, Screws, Studs, and Rivets, Inch and Metric Series](#)

[F1470 Practice for Fastener Sampling for Specified Mechanical Properties and Performance Inspection](#)

[F1789 Terminology for F16 Mechanical Fasteners](#)

[F1940 Test Method for Process Control Verification to Prevent Hydrogen Embrittlement in Plated or Coated Fasteners](#)

[F2282 Specification for Quality Assurance Requirements for Carbon and Alloy Steel Wire, Rods, and Bars for Mechanical Fasteners](#)

[F2328 Test Method for Determining Decarburization and Carburization in Hardened and Tempered Threaded Steel Bolts, Screws, Studs, and Nuts](#)

¹ This specification is under the jurisdiction of ASTM Committee F16 on Fasteners and is the direct responsibility of Subcommittee F16.02 on Steel Bolts, Nuts, Rivets and Washers.

Current edition approved June 1, 2017/Dec. 1, 2021. Published June 2017/February 2022. Originally approved in 1967. Last previous edition approved in 2016/2017 as A574–16/A574–17. DOI: 10.1520/A0574-17.10.1520/A0574-21.

² For referenced ASTM standards, visit the ASTM website, www.astm.org, or contact ASTM Customer Service at service@astm.org. For *Annual Book of ASTM Standards* volume information, refer to the standard's Document Summary page on the ASTM website.

*A Summary of Changes section appears at the end of this standard

2.2 *ASME Standards*:³

B18.3 Socket Cap, Shoulder, and Set Screws

B18.12 Glossary of Terms for Mechanical Fasteners

B18.24 Part Identifying Number (PIN) Code System Standard for B18 Fastener Products

3. Terminology

3.1 *Definitions of Terms Specific to This Standard*—The definition of terms used in this specification shall be as specified in Terminology **F1789**, ASME B18.12, or the applicable referenced standards, unless otherwise defined herein. In the event that there are differences for a given term, ASTM definitions shall be used.

4. Ordering Information

4.1 Orders for socket head cap screws under this specification shall include the following information:

4.1.1 ASTM designation and year of issue.

4.1.2 Name of the screw (SHCS).

4.1.3 Quantity (number of pieces by size).

4.1.4 Dimensions, including nominal thread designation, thread pitch, and nominal screw length.

4.2 Orders for socket head cap screws shall include the following optional requirements if specified by the purchaser:

4.2.1 Inspection at point of manufacture.

4.2.2 Coating, if a protective finish other than those, which are described in 5.5 is required, it must be specified (see 5.6).

4.2.3 Test reports or certificate of conformance, as required (see Section 15).

4.2.4 Additional testing (see 12.1).

4.2.5 Special packaging (see 18.1.2).

4.2.6 Supplementary requirements (see S1).

4.2.7 Special requirements.

4.2.8 For establishment of a part identifying system, see ASME B18.24.

5. Materials and Manufacture

5.1 The screws shall be fabricated from alloy steel made to a fine grain practice. In the event of controversy over grain size, referee tests on finished screws conducted in accordance with Test Methods **E112** shall prevail.

5.2 Screws in sizes through 0.750 in. diameter, and with lengths through ten times the nominal product size or 6.0 inches, whichever is shorter, shall be cold headed, except that when specified by the purchaser the screws shall be hot headed. Larger sizes and longer lengths shall be cold or hot headed at the option of the manufacturer, unless otherwise specified by the purchaser. Screws larger than 1.500 in. nominal diameter shall be permitted to be machined. Sockets shall be forged or machined at the option of the manufacturer.

5.3 Screws in sizes through 0.625 in. diameter, and for product lengths through 4 in. shall be roll threaded, unless otherwise specified by the purchaser. Larger products shall be rolled, cut, or ground at the option of the manufacturer.

³ Available from American Society of Mechanical Engineers (ASME), ASME International Headquarters, Two Park Ave., New York, NY 10016-5990, <http://www.asme.org>.

5.4 Screws shall be heat treated by quenching in oil from above the transformation temperature and then tempered by reheating to at least 700°F to achieve the mechanical properties specified in Section 7 and Table 1.

5.4.1 When specified by the purchaser, the minimum tempering temperature shall be verified by subjecting screws to 680°F for 30 minutes at temperature. The mean cross section hardness of three readings on the screw before and after retempering shall not differ by more than 2 points hardness Rockwell C (HRC).

5.5 *Standard Finishes*—Unless otherwise specified, the screws shall be furnished with one of the following “standard surfaces as manufactured” at the option of the manufacturer: (1) bright uncoated, (2) thermal black oxide, or (3) chemical black oxide. Hydrogen embrittlement tests shall not be required for screws furnished in these conditions.

5.6 *Protective Coatings:*

5.6.1 When a protective finish other than as specified in 5.5 is required, it shall be specified on the purchase order with the applicable finish specification.

5.6.2 When protective or decorative coatings are applied to the screws, precautions specified by the coating requirements to minimize internal hydrogen embrittlement shall be exercised. Additional precautions such as the requirements in Test Method F1940 and Test Methods F606/F606M shall be by agreement with the purchaser.

6. Chemical Composition

6.1 The screws shall be alloy steel conforming to the chemical composition specified in Table 2 and the requirements in Specification F2282. See Supplementary Requirement S1 when additional alloy steel grades are required.

6.2 One or more of the following alloying elements: chromium, nickel, molybdenum, or vanadium shall be present in sufficient quantity to ensure that the specified strength properties are met after oil quenching and tempering. As a guide for selecting material, an alloy steel should be capable of meeting the specified mechanical requirements if the “as oil quenched” core hardness one diameter from the point is equal to or exceeds 25 HRC + (55 × carbon content).

6.3 When product analyses are made by the purchaser from finished screws representing each lot, the chemical composition, thus determined, shall conform to the requirements prescribed for product analysis in Table 2.

6.4 Steel to which bismuth, selenium, tellurium, or lead has been intentionally added shall not be permitted.

6.5 Chemical analyses shall be performed in accordance with Test Methods, Practices, and Terminology A751.

TABLE 1 Mechanical Requirements

Property	≤0.5 in. Nom. Dia.	>0.5 in. and < 1.0 in. Nom. Dia.	≥1.0 in. Nom. Dia.
Full-size screws:			
Tensile or wedge tensile strength, min, ksi	180	170	170
Proof load (stress), ksi	140	135	135
Product hardness:			
Rockwell (HRC)	39–44	37–44	37–44
Machined test specimen:			
Yield strength at 0.2% offset, min., ksi	A	A	153
Tensile strength, min., ksi	A	A	170
Elongation in 4D, min.	A	A	10%
Reduction of area, min.	A	A	35%

^A Not Applicable.

TABLE 2 Chemical Requirements

Element	Composition, %	
	Heat Analysis	Product Analysis
Carbon, min	0.33	0.31
Phosphorus, max	0.035	0.040
Sulfur, max	0.040	0.045
Alloying elements	See 6.2	

7. Mechanical Properties

7.1 Socket head cap screws shall be tested in accordance with the mechanical testing requirements specified in Table 3, and shall meet the mechanical requirements in Table 1, and either Table 4 or Table 5.

NOTE 1—For design purposes only, a minimum yield strength at 2%2% offset of 153 ksi may be assumed for bolt diameters less than 1.0 in.

7.2 The screws that are tested for wedge tensile strength shall utilize a wedge of the angle specified in Table 6 under the head. To meet the requirements of the wedge test, there must be a tensile failure in the body or thread section. For the purpose of this test, failure means separation into two pieces. Screws threaded to the head shall pass the requirements for this test if the fracture that caused failure originated in the thread area, even though it may have propagated into the fillet area or the head before separation.

8. Metallurgical Requirement

8.1 *Carburization or Decarburization:*

8.1.1 There shall be no evidence of carburization or total decarburization on the surfaces of the heat-treated screws when measured in accordance with Test Method F2328 (Class 3 Product).

8.1.2 The depth of partial decarburization shall be limited to the values in Test Method F2328 (Class 3 Product) when measured as described therein.

9. Dimensions

ASTMA574-21
<https://standards.iteh.ai/catalog/standards/sist/5c30932f-dff4-4985-8819-618679da031e/astm-a574-21>

9.1 Unless otherwise specified, the product shall conform to the requirements of ASME B18.3.

10. Workmanship, Finish, and Appearance

10.1 *Surface Discontinuities*—The surface discontinuities for these products shall conform to Specification F788 and the additional limitations specified herein.

TABLE 3 Mechanical Testing Requirements

Item	Nom. Dia.	Tensile Load, min, lb	Product Length	Hardness, max	Hardness, min	Decarb/Carburization	Test Conducted Using Full Size Product			Test Conducted Using Machined Test Specimen			
							Proof Load	Wedge Tensile Strength	Axial Tensile Strength	Yield Strength at 0.2% Offset	Tensile Strength	Elongation	% Red. of Area
1	All short lengths	...	Less than 3D ^A	B	B	B
2	<1.0 in.	...	Over 3D ^A	B	...	B	Z ^C	B
3	≥1.0 in.	≤270,000	Over 3D ^A	B	...	B	Z ^C	X ^D	...	Y ^D	Y ^D	Y ^D	Y ^D
3	≥1.0 in.	≤270,000	Over 3D ^A	B	...	B	Z ^C	X ^D	...	Y ^D	Y ^D	Y ^D	Y ^D
4	≥1.0 in.	>270,000	Over 3D ^A	B	...	B	Z ^C	...	X ^D	Y ^D	Y ^D	Y ^D	Y ^D
4	≥1.0 in.	>270,000	Over 3D ^A	B	...	B	Z ^C	...	X ^D	Y ^D	Y ^D	Y ^D	Y ^D

^A D denotes nominal diameter of product.

^B Denotes mandatory test.

^C Proof load test denoted Z shall be conducted when purchaser requests the test in inquiry and order.

^D Either all tests denoted by X or all tests denoted by Y shall be performed. In case of arbitration full-size tests, denoted X, shall be decisive.

TABLE 4 Tensile Requirements for Coarse Thread Screws

Screw Dia (<i>D</i>), in.	Threads/in.	Tensile Load, min, lbf ^A	Stress Area, in. ² ^B	Proof Load (Length Measurement Method), min, lbf ^C
0.073	64	473	0.00263	368
0.086	56	666	0.00370	518
0.099	48	877	0.00487	682
0.112	40	1 090	0.00604	846
0.125	40	1 430	0.00796	1 110
0.138	32	1 640	0.00909	1 270
0.164	32	2 520	0.0140	1 960
0.190	24	3 150	0.0175	2 450
0.216	24	4 350	0.0242	3 380
0.250	20	5 730	0.0318	4 450
0.3125	18	9 440	0.0524	7 340
0.375	16	13 900	0.0775	10 800
0.4375	14	19 100	0.1063	14 900
0.500	13	25 500	0.1419	19 900
0.5625	12	30 900	0.182	24 600
0.625	11	38 400	0.226	30 500
0.750	10	56 800	0.334	45 100
0.875	9	78 500	0.462	62 400
1.000	8	103 000	0.606	81 800
1.125	7	129 000	0.763	103 000
1.250	7	165 000	0.969	131 000
1.375	6	196 000	1.155	156 000
1.500	6	239 000	1.405	190 000
1.750	5	323 000	1.90	256 000
2.000	4½	425 000	2.50	338 000
2.250	4½	552 000	3.25	439 000
2.500	4	680 000	4.00	540 000
2.750	4	838 000	4.93	666 000
3.000	4	1 010 000	5.97	806 000
3.250	4	1 210 000	7.10	958 000
3.500	4	1 420 000	8.33	1 120 000
3.750	4	1 640 000	9.66	1 300 000
4.000	4	1 880 000	11.08	1 500 000

^A Values based on 180 ksi for 0.500 and smaller and 170 ksi for sizes larger than 0.500 in. and stress area in accordance with Footnote B.

^B Stress areas based on Handbook H-28 (U.S. Department of Commerce) as follows:

$$A_s = 0.7854 [D - (0.9743/n)]^2$$

where:

- A_s = stress area,
- D = nominal screw size, and
- n = threads/in.

^C Values based on 140 ksi for 0.500 and smaller and 135 ksi for sizes larger than 0.500 in. and stress area in accordance with Footnote B.

10.2 Forging Cracks:

10.2.1 Forging cracks that connect the socket to the periphery of the head as shown in Fig. 1 are not permissible.

10.2.2 Forging cracks originating on the periphery of the head and with a traverse indicating a potential to intersect on the top of the socket head as shown in Fig. 1 are not permissible.

10.2.3 Other forging cracks are permissible provided those that are located in the bearing area, fillet, and top surfaces do not have a depth exceeding 0.03*D* or 0.005 in., whichever is greater. For peripheral discontinuities, the maximum depth shall be 0.06*D* or 0.064 in., whichever is greater (see Fig. 1).

10.2.4 Forging cracks located in the socket wall within 0.1 times the actual key engagement (*T*) from the bottom of the socket are not permissible. Discontinuities located elsewhere in the socket shall not have a length exceeding 0.25*T*, or a maximum depth of 0.03*D* or 0.005 in., whichever is greater (see Fig. 2).

TABLE 5 Tensile Requirements for Fine Thread Screws

Screw Dia (<i>D</i>), in.	Threads/in.	Tensile Load, min, lbf ^A	Stress Area, in. ² ^B	Proof Load (Length Measurement Method) min, lbf ^C
0.060	80	324	0.00180	252
0.073	72	500	0.00278	389
0.086	64	709	0.00394	552
0.099	56	941	0.00523	732
0.112	48	1 190	0.00661	925
0.125	44	1 490	0.00830	1 160
0.138	40	1 830	0.01015	1 420
0.164	36	2 650	0.01474	2 060
0.190	32	3 600	0.0200	2 800
0.250	28	6 500	0.0364	5 100
0.216	28	4 600	0.0258	3 600
0.3125	24	10 400	0.0580	8 120
0.375	24	15 800	0.0878	12 300
0.4375	20	21 400	0.1187	16 600
0.500	20	28 800	0.1599	22 400
0.5625	18	34 500	0.203	27 400
0.625	18	43 500	0.256	34 600
0.750	16	63 400	0.373	50 400
0.875	14	86 500	0.509	68 700
1.000	12	113 000	0.663	89 500
1.125	12	146 000	0.856	116 000
1.250	12	182 000	1.073	145 000
1.375	12	224 000	1.315	178 000
1.500	12	269 000	1.581	213 000

^A Values based on 180 ksi for 0.500 and smaller and 170 ksi for sizes larger than 0.500 in. and stress area in accordance with Footnote *B*.

^B Stress areas based on H-28 as follows:

$$A_s = 0.7854 [D - (0.9743/n)]^2$$

where:

- A_s* = stress area,
- D* = nominal screw size, and
- n* = threads/in.

^C Values based on 140 ksi for 0.500 and smaller and 135 ksi for sizes larger than 0.500 in. and stress area in accordance with Footnote *B*.

ASTMA574-21

<https://standards.iteh.ai/catalog/standard/ASTM-A574-21> **TABLE 6 Wedge Test Angles** <https://standards.iteh.ai/catalog/standard/ASTM-A574-21>

Screw Size, <i>D</i> , in.	Wedge Angle, Deg	
	Body Lengths <i>2D</i> or Less or Threaded to the Head	Body Lengths Greater than <i>2D</i>
0.112 – 0.500, incl	6	10
0.625 – 0.750, incl	6	8
0.5625 – 0.750, incl	6	8
0.875 to 1.500, incl	4	6

10.3 Seams in the shank shall not exceed a depth of 0.03*D* or 0.005 in., whichever is greater.

10.4 *Thread Discontinuities*—Threads shall have no laps at the root or on the flanks located below the pitch line, as shown in Fig. 3, when inspected in accordance with Specification F788, S1.2. Laps are permissible at the thread crest (Fig. 3C) to a depth of 25 % of the basic thread height and on the thread flanks above the pitch diameter. Longitudinal seams rolled beneath the root of the thread and across the crests of the threads are acceptable within the limits of 10.3.

11. Sampling and Number of Tests

11.1 Guide F1470 shall be used to determine the necessary sampling plan and the number of tests that must be performed to demonstrate that all of the requirements of this standard are met for each lot.

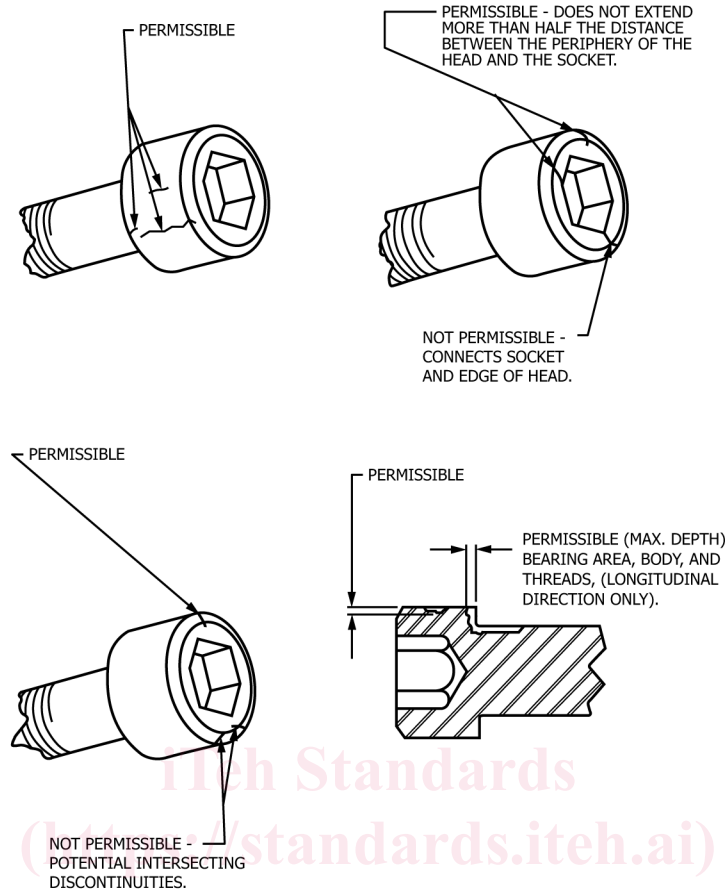

FIG. 1 Head and Body Discontinuity Location and Limits

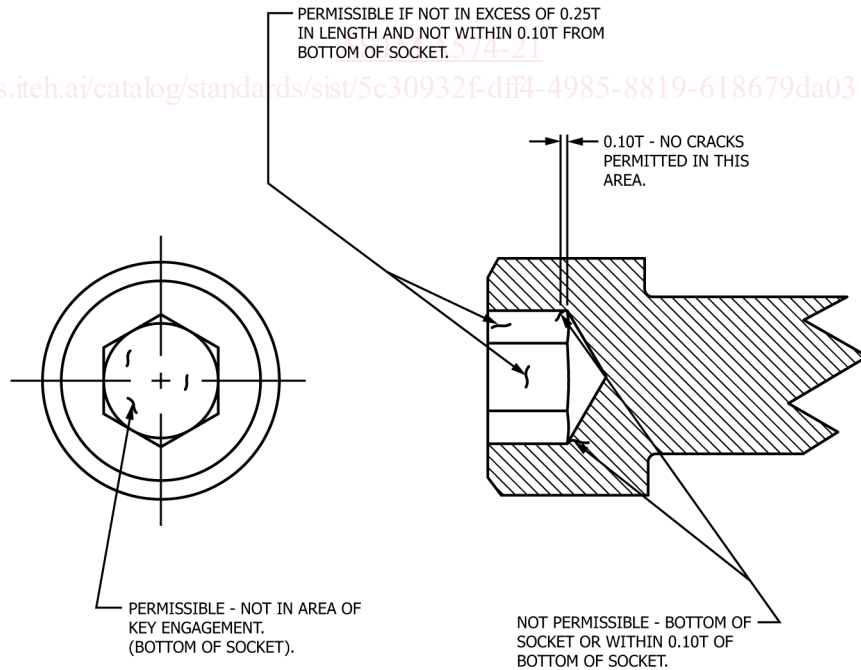

FIG. 2 Socket Discontinuity Location and Limits