



Designation: **D5242–92 (Reapproved 2013) D5242 – 21**

Standard Test Method for Open-Channel Flow Measurement of Water with Thin-Plate Weirs¹

This standard is issued under the fixed designation D5242; the number immediately following the designation indicates the year of original adoption or, in the case of revision, the year of last revision. A number in parentheses indicates the year of last reapproval. A superscript epsilon (ϵ) indicates an editorial change since the last revision or reapproval.

1. Scope

1.1 This test method covers measurement of the volumetric ~~flow rate~~ flow rate of water and wastewater in channels with thin-plate weirs. Information related to this test method can be found in Rantz (1)² and Ackers (2).

1.2 The values stated in inch-pound units are to be regarded as the standard. The ~~SI units values~~ values given in parentheses are for information only; mathematical conversions to SI units that are provided for information only and are not considered standard.

1.3 *This standard does not purport to address all of the safety concerns, if any, associated with its use. It is the responsibility of the user of this standard to establish appropriate safety, health, and environmental practices and determine the applicability of regulatory limitations prior to use.*

1.4 *This international standard was developed in accordance with internationally recognized principles on standardization established in the Decision on Principles for the Development of International Standards, Guides and Recommendations issued by the World Trade Organization Technical Barriers to Trade (TBT) Committee.*

2. Referenced Documents

2.1 ASTM Standards:³

D1129 Terminology Relating to Water

D2777 Practice for Determination of Precision and Bias of Applicable Test Methods of Committee D19 on Water

D3858 Test Method for Open-Channel Flow Measurement of Water by Velocity-Area Method

2.2 ISO Standards:⁴

ISO 1438 Flow Measurement in Open Channels Using Weirs and Venturi Flumes—Part 1: Thin-Plate Weirs

ISO 555 Liquid Flow Measurement in Open Channels, Delusion Methods for Measurement of Steady Flow-Constant Rate Injection Method

3. Terminology

3.1 Definitions:

3.1.1 For definitions of terms used in this ~~test method, standard,~~ refer to Terminology **D1129**.

3.2 Definitions of Terms Specific to This Standard:

¹ This test method is under the jurisdiction of ASTM Committee **D19** on Water and is the direct responsibility of Subcommittee **D19.07** on Sediments, Geomorphology, and Open-Channel Flow.

Current edition approved Jan. 1, 2013Dec. 15, 2021. Published January 2013January 2022. Originally approved in 1992. Last previous edition approved in 20072013 as D5242 – 92 (2007)(2013). DOI: 10.1520/D5242-92R13.10.1520/D5242-21.

² The boldface numbers in parentheses refer to a list of references at the end of the text.

³ For referenced ASTM standards, visit the ASTM website, www.astm.org, or contact ASTM Customer Service at service@astm.org. For *Annual Book of ASTM Standards* volume information, refer to the standard's Document Summary page on the ASTM website.

⁴ Available from American National Standards Institute (ANSI), 25 W. 43rd St., 4th Floor, New York, NY 10036, http://www.ansi.org.

- 3.2.1 *crest*—crest, n—the bottom of the overflow section or notch of a rectangular weir.
- 3.2.2 *head*—head, n—the height of a liquid above a specified point, for example, the weir crest.
- 3.2.3 *hydraulic jump*—jump, n—an abrupt transition from supercritical flow to subcritical or tranquil flow.
- 3.2.4 *nappe*—nappe, n—the curved sheet or jet of water overfalling the weir.
- 3.2.5 *notch*—notch, n—the overflow section of a triangular weir or of a rectangular weir with side contractions.
- 3.2.6 *primary instrument*—instrument, n—the device (in this case the weir) that creates a hydrodynamic condition that can be sensed by the secondary instrument.
- 3.2.7 *scow float*—float, n—an in-stream float for depth sensing, usually mounted on a hinged cantilever.
- 3.2.8 *secondary instrument*—instrument, n—in this case, a device that measures the depth of flow (referenced to the crest) at an appropriate location upstream of the weir plate. The secondary instrument may also convert the measured depth to an indicated flowrate—flow rate.
- 3.2.9 *stilling well*—well, n—a small free-surface reservoir connected through a constricted channel to the approach channel upstream of the weir so that a depth (head) measurement can be made under quiescent conditions.
- 3.2.10 *subcritical flow*—flow, n—open channel flow in which the average velocity is less than the square root of the product of the average depth and the acceleration due to gravity; sometimes called tranquil flow.
- 3.2.11 *submergence*—submergence, n—a condition where the water level on the downstream side of the weir is at the same or at a higher elevation than the weir crest; depending on the percent of submergence the flow over the weir and hence the head-discharge relation may be altered.
- 3.2.12 *supercritical flow*—flow, n—open channel flow in which the average velocity exceeds the square root of the product of the average depth and the acceleration due to gravity.
- 3.2.13 *tailwater*—tailwater, n—the water level immediately downstream of the weir.

4. Summary of Test Method

- 4.1 Thin-plate weirs are overflow structures of specified geometries for which the volumetric flowrate—flow rate is a unique function of a single measured depth (head) above the weir crest or vertex, the other factors in the head-discharge relation having been experimentally or analytically determined as functions of the shape of the overflow section and approach channel geometry.

5. Significance and Use

- 5.1 Thin-plate weirs are reliable and simple devices that have the potential for highly accurate flow measurements. With proper selection of the shape of the overflow section a wide range of discharges can be covered; the recommendations in this test method are based on experiments with flowrates—flow rates from about 0.008 ft³/s (0.00023 m³/s) to about 50 ft³/s (1.4 m³/s).

5.2 Thin-plate weirs are particularly suitable for use in water and wastewater without significant amounts of solids and in locations where a head loss is affordable.

6. Interferences

- 6.1 Because of the velocities are reduced ~~velocities~~ in the backwater upstream of the weir, solids normally transported by the flow will tend to deposit and ultimately affect the approach conditions.

6.2 Weirs are applicable only to open channel flow and become inoperative under pressurized-conduit conditions.

7. Apparatus

7.1 A weir measuring system consists of the weir plate and its immediate channel (the primary) and a depth (head) measuring device (the secondary). The secondary device can range from a simple scale for manual readings to an instrument that continuously senses the depth, converts it to a ~~flowrate,~~ flow rate, and displays or transmits a readout or record of the instantaneous ~~flowrate~~ flow rate or totalized flow, or both.

7.2 *Thin-Plate Weir:*

7.2.1 *Shapes*—The thin-plate weir provides a precisely shaped overflow section symmetrically located in a (usually) rectangular approach section, as in Fig. 1 and Fig. 2. Although information is available in the literature (3) on a variety of overflow-section or notch shapes (for example, rectangular, triangular, trapezoidal, circular) only the rectangular and triangular shapes are considered to have a data base sufficient for promulgation as a standard method.

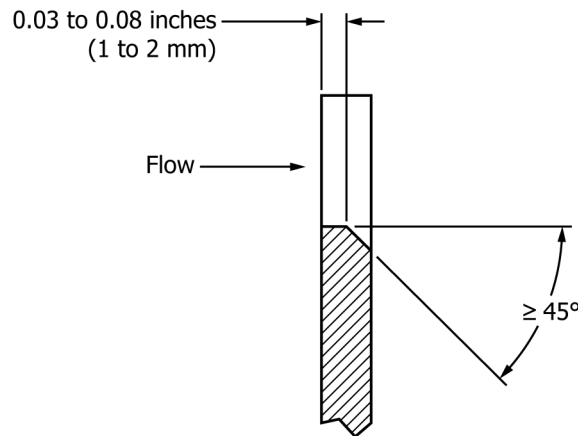
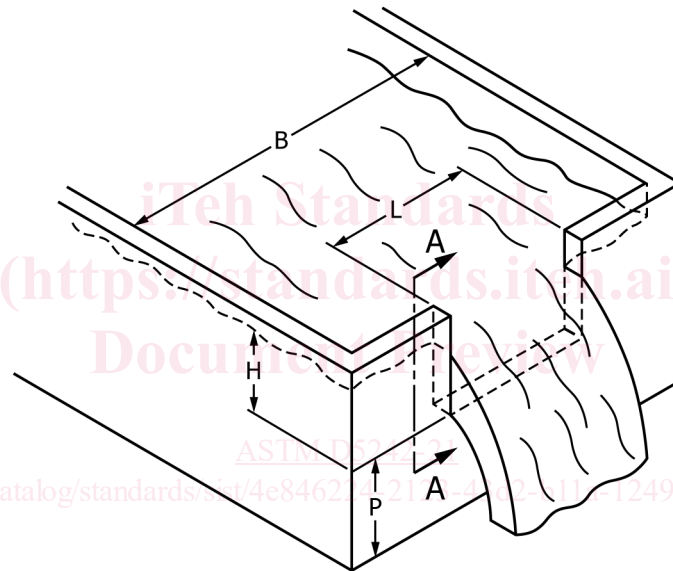

Notch edge section (A-A).

FIG. 1 Rectangular Weir

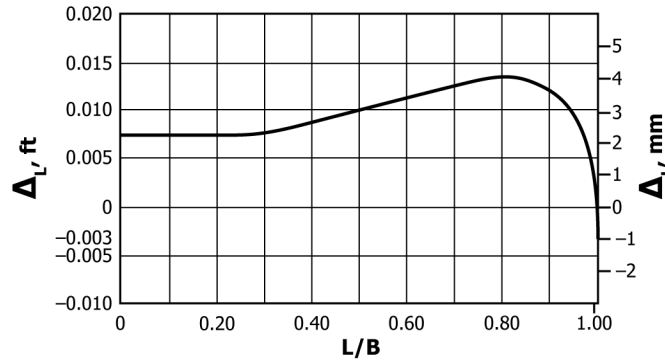

FIG. 2 Crest-Length Adjustment, Δ_L

7.2.2 Weir Plate:

7.2.2.1 The plate thickness in the direction of flow must be from 0.03 to 0.08 in. (about 1 to 2 mm); the lower limit is prescribed to minimize potential damage, and the upper limit is required to help avoid nappe clinging. See 7.2.5.4 and 7.2.6.3 for plates thicker than 0.08 in. (2 mm). The plate must be fabricated of smooth metal or other material of equivalent smoothness and sturdiness. Upstream corners of the overflow section must be sharp and burr-free, and the edges must be flat, smooth, and perpendicular to the weir face.

7.2.2.2 The plane of the weir plate must be vertical and perpendicular to the channel walls. The overflow section must be laterally symmetrical and its bisector must be vertical and located at the lateral midpoint of the approach channel. If the metal plate containing the overfall section does not form the entire weir, it must be mounted on the remainder of the bulkhead so that the upstream face of the weir is flush and smooth. (This requirement may be relaxed if the metal plate is large enough in itself to form full contractions. See 7.2.3.) The weir structure must be firmly mounted in the channel so that there is no leakage around it.

7.2.2.3 Additional plate requirements specific to rectangular and triangular weirs are given in 7.2.5.4 and 7.2.6.3.

7.2.3 Weir Contractions—When the sidewalls and bottom of the approach channel are far enough from the edges of the notch for the contraction of the nappe to be unaffected by those boundaries, the weir is termed “fully contracted.” With lesser distances to the bottom or sidewalls, or both, the weir is “partially contracted.” Contraction requirements specific to rectangular and triangular weirs are given in 7.2.5.3, 7.2.5.6, 7.2.6.2, and 7.2.6.5.

7.2.4 Head Measurement Location—The head on the weir, H , is measured as a depth above the elevation of the crest or vertex of the notch. This measurement should be made at a distance upstream of the weir equal to $4 H_{max}$ to $5 H_{max}$, where H_{max} is the maximum head on the weir. In some cases a stilling well may be desirable or necessary. See 7.5.

7.2.5 Rectangular Weirs:

7.2.5.1 The rectangular overflow section can have either full or partial contractions (7.2.3) or the side contractions may be suppressed (7.2.5.2).

7.2.5.2 Suppressed Weirs—When there are no side contractions and the weir crest extends across the channel, the weir is termed “full width” or “suppressed.” In this case the approach channel must be rectangular (see also 7.3.4) and the channel walls must extend at least $0.3H$ downstream of the weir plate.

7.2.5.3 Contracted Rectangular Weirs—The conditions for full contraction are as follows:

H/P	≤ 0.5
H/L	≤ 0.5
0.25 ft (0.08 m)	$\leq H \leq 2.0 \text{ ft (0.6 m)}$
L	$\geq 1.0 \text{ ft (0.3 m)}$
P	$\geq 1.0 \text{ ft (0.3 m)}$
$(B - L)/2$	$\geq 2H$

where H is the measured head, P is the crest height above the bottom of the channel, L is the crest length, and B is the channel width. The partial contraction conditions covered by this test method are given in 7.2.5.6.

7.2.5.4 *Weir Plate*—The requirements of this section are in addition to those of 7.2.2. If the plate is thicker than 0.08 in. (2 mm) the downstream excess at the edges of the overflow section must be beveled at an angle of at least 45° as shown in Fig. 1. If there are side contractions, all of the edge requirements of this test method pertain to the sides as well as the crest. The sides must be exactly perpendicular to the crest; and the crest must be level, preferably to within a transverse slope of 0.001.

7.2.5.5 *Discharge Relations*—The flowrate, flow rate, Q , over a rectangular weir that conforms to all requirements of 7.2 as well as the approach conditions in 7.3 is determined from the Kindsvater-Carter equation (4):

$$Q = (2/3)(2g)^{1/2}C_e L_e (H_e)^{3/2} \tag{1}$$

where g is the acceleration due to gravity in compatible units, H_e and L_e are the effective head and effective crest length respectively, and C_e is a discharge coefficient. The effective head, H_e , is related to the measured head, H , by:

$$H_e = H + \delta H$$

where δH is an experimentally determined adjustment for the effects of viscosity and surface tension valid for water at ordinary temperatures (about 4 to 30°C); its value is constant at 0.003 ft (0.001 m). The effective crest length, L_e , is related to the measured length, L , by:

$$L_e = L + \delta L$$

where the adjustment, δL , is a function of the crest length-to-channel width ratio, L/B . Experimentally determined values of δL for water at ordinary temperatures are given in Fig. 3.

The discharge coefficient, C_e , is given in Fig. 4 as a function of L/B and the head-to-crest height ratio, H/P .

7.2.5.6 *Limits of Application*—The discharge relations given in 7.2.5.5 are applicable for these conditions:

H/P	≤ 2
H	≥ 0.1 ft (0.03 m)
L	≥ 0.5 ft (0.15 m)
P	≥ 0.3 ft (0.1 m)

Although in principle Eq 1 could be applied to very large weirs, the experiments on which it is based included crest lengths up to about 4 ft (1.2 m) and heads up to about 2 ft (0.6 m); it is recommended that these values not be significantly exceeded.

7.2.5.7 *Aeration Requirements*—In order to avoid nappe clinging and maintain proper aeration of the nappe, the tailwater level should always be at least 0.2 ft (0.06 m) below the crest. In addition, in the case of suppressed weirs, aeration must be provided externally; this can be done with sidewall vents, for example. The user must measure the pressure in the air pocket to establish that it is sufficiently close to atmospheric for the flow to be unaffected (see 11.7.2).

7.2.6 *Triangular Weirs:*

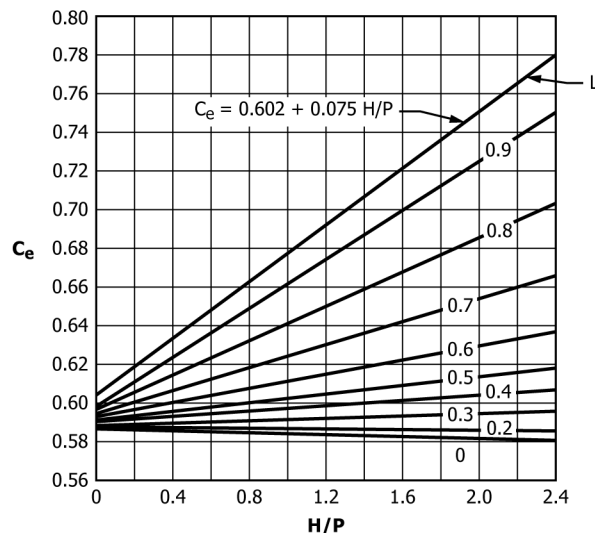

FIG. 3 Discharge Coefficient, C_e , for Rectangular Weirs

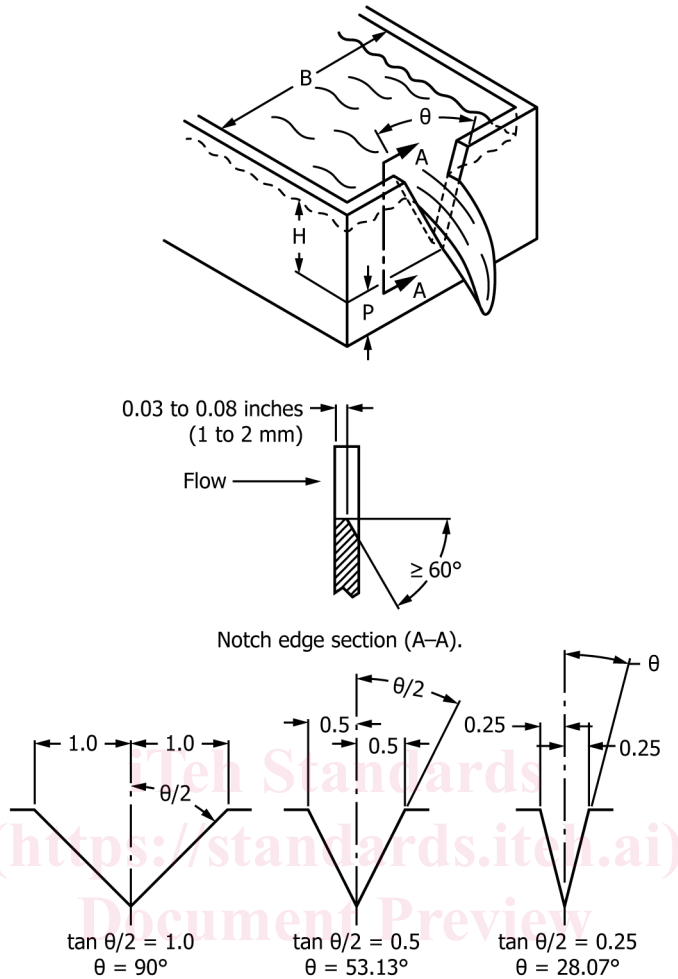

FIG. 4 Triangular Weirs

<https://standards.iteh.ai/catalog/standards/sist/4e846224-2123-43d2-b11a-1249c80af7b2/astm-d5242-21>

7.2.6.1 *Shape*—The overflow section of a triangular weir is an isosceles triangle oriented with the vertex downward. Experimental results are available for notch angles, θ , of 20 to 100°. However, the most commonly used weirs are 90° ($\tan \theta/2 = 1$), 53.13° ($\tan \theta/2 = 0.5$) and 28.07° ($\tan \theta/2 = 0.25$). See Fig. 2.

7.2.6.2 *Contractions*—The conditions for full contraction of triangular weirs are as follows:

H/P	≤ 0.4
H/B	≤ 0.2
P	≥ 1.5 ft (0.45 m)
B	≥ 3.0 ft (0.9 m)
0.15 ft (0.05 m)	$\leq H \leq 1.25$ ft (0.38 m)

The conditions for partial contraction covered by this test method are listed in 7.2.6.5.

7.2.6.3 *Weir Plate*—If the plate is thicker than 0.08 in. (2 mm) the downstream excess at the notch must be beveled at an angle of at least 60° (Fig. 2). This requirement is in addition to those of 7.2.2.

7.2.6.4 *Discharge Relations*—The flow rate over a triangular weir that conforms to all requirements of 7.2.3 as well as the approach conditions in 7.3 is determined from the following:

$$Q = (8/15)(2g)^{1/2} C_{e_t} \tan(\theta/2) (H_{e_t})^{5/2} \quad (2)$$

where C_{e_t} and H_{e_t} are the discharge coefficient and effective head respectively. H_{e_t} is given by:

$$H_{e_t} = H + \delta_{H_t}$$

where δ_{H_t} is an adjustment for the combined effects of viscosity and surface tension for water at ordinary temperatures (4 to 30°C) and is given as a function of notch angle in Fig. 5. The discharge coefficient is given in Fig. 6 as a function of the notch angle for fully contracted weirs only. For partially contracted weirs the data base is considered adequate for 90° notches only and these discharge coefficients are shown in Fig. 7.

7.2.6.5 *Limits of Application*—For 90° notches only, the discharge relations given in 7.2.6.4 are valid for these partially contracted conditions:

H/P	≤ 1.2
H/B	≤ 0.4
P	≥ 0.3 ft (0.1 m)
B	≥ 2 ft (0.6 m)
0.15 ft (0.05 m)	$\leq H \leq 2$ ft (0.6 m)

For other angles between 20 and 100° the discharge relations are valid only for full contractions (see 7.2.6.2).

7.2.6.6 *Aeration Requirements*—In order to avoid nappe clinging and maintain proper aeration of the nappe, the tailwater level should always be at least 0.2 ft (0.05 m) below the vertex of the triangular notch.

7.3 *Approach Channel:*

7.3.1 Weirs can be sensitive to the quality of the approach flow. Therefore this flow should be tranquil and uniformly distributed across the channel in order to closely approximate the conditions of the experiments from which the discharge relations were developed. For this purpose, uniform velocity distribution can be defined as that associated with fully developed flow in a long, straight, moderately smooth channel. Unfortunately there are no universally accepted quantitative guidelines for implementing these recommendations. One standard (5) recommends a straight approach length of ten channel widths when the weir length is greater than half the channel width. However, the presence of upstream channel bends or sudden enlargements would clearly lengthen this approach requirement. Therefore the adequacy of the approach flow generally must be demonstrated on a case-by-case basis using velocity traverses, experience with similar situations, or analytical approximations.

7.3.2 In some cases baffles can be used to improve the velocity distribution; they must be placed more than 10H upstream of the head measurement location.

7.3.3 If the flow in the channel is supercritical, the installation should be designed so that the hydraulic jump is formed at least 30H upstream and the velocity distribution should be checked for uniformity.

7.3.4 *Channel Shape*—A rectangular approach channel is preferred in the immediate vicinity of the weir. However, a different shape is acceptable provided the conditions for full contraction are met and the cross-sectional area of the channel is at least as large as the smallest rectangular section that would have provided full contraction. Rectangular channels are required for suppressed rectangular weirs.

7.4 *Submerged Weirs*—This section provides limited information on the performance of submerged weirs. However, it is strongly recommended that weir installations be designed for free flow because the experimental data base for submerged conditions is not adequate to provide the accuracy appropriate for a standard test method. Further, submerged conditions require that an additional head (relative to the crest or vertex) be measured downstream of the weir so that the submergence (ratio of downstream head to upstream head) can be determined; this measurement must be made in a manner that is unaffected by the disturbances downstream

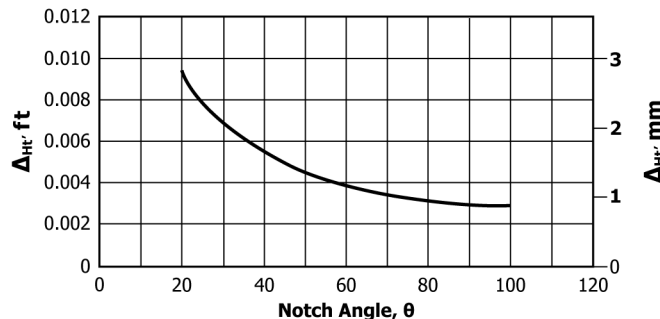

FIG. 5 Head Correction, Δ_{H_t} for Triangular Weirs