



Designation: D5413 – 21

# Standard Test Methods for Measurement of Water Levels in Open-Water Bodies<sup>1</sup>

This standard is issued under the fixed designation D5413; the number immediately following the designation indicates the year of original adoption or, in the case of revision, the year of last revision. A number in parentheses indicates the year of last reapproval. A superscript epsilon ( $\epsilon$ ) indicates an editorial change since the last revision or reapproval.

## 1. Scope

1.1 These test methods cover equipment and procedures used in obtaining water levels of rivers, lakes, and reservoirs or other water bodies. Three types of equipment are available as follows:

Test Method A—Nonrecording water-level measurement devices

Test Method B—Recording water-level measurement devices

Test Method C—Remote-interrogation water-level measurement devices

1.2 The procedures detailed in these test methods are widely used by those responsible for investigations of streams, lakes, reservoirs, and estuaries, for example, the U.S. Agricultural Research Service, the U.S. Army Corp of Engineers, and the U.S. Geological Survey.<sup>2</sup> The referenced ISO standard also furnishes useful information.

1.3 It is the responsibility of the user of these test methods to determine the acceptability of a specific device or procedure to meet operational requirements. Compatibility between sensors, recorders, retrieval equipment, and operational systems is necessary, and data requirements and environmental operating conditions must be considered in equipment selection.

1.4 The values stated in inch-pound units are to be regarded as standard. The values given in parentheses are mathematical conversions to SI units that are provided for information only and are not considered standard.

1.5 *This standard does not purport to address all of the safety concerns, if any, associated with its use. It is the responsibility of the user of this standard to establish appropriate safety, health, and environmental practices and determine the applicability of regulatory limitations prior to use.*

1.6 *This international standard was developed in accordance with internationally recognized principles on standardization established in the Decision on Principles for the Development of International Standards, Guides and Recom-*

*mendations issued by the World Trade Organization Technical Barriers to Trade (TBT) Committee.*

## 2. Referenced Documents

2.1 *ASTM Standards:*<sup>3</sup>

**D1129 Terminology Relating to Water**

**D1941 Test Method for Open Channel Flow Measurement of Water with the Parshall Flume**

**D2777 Practice for Determination of Precision and Bias of Applicable Test Methods of Committee D19 on Water**

**D5242 Test Method for Open-Channel Flow Measurement of Water with Thin-Plate Weirs**

2.2 *ISO Standard:*<sup>4</sup>

**ISO 4373 Measurement of Liquid Flow in Open Channels—Water Level Measuring Devices**

## 3. Terminology

3.1 *Definitions:*

3.1.1 For definitions of terms used in this standard, refer to Terminology **D1129**.

3.2 *Definitions of Terms Specific to This Standard:*

3.2.1 *elevation, n*—the vertical distance from a datum to a point.

3.2.2 *datum, n*—a level plane that represents a zero or some defined elevation.

3.2.3 *gauge, n*—a generic term that includes water level measuring devices.

3.2.4 *gauge datum, n*—a datum whose surface is at the zero elevation of all the gauges at a gauging station; this datum is often at a known elevation referenced to National Geodetic Vertical Datum of 1929 (NGVD).

3.2.5 *gauge height, n*—the height of a water surface above an established or arbitrary datum at a particular gauging station; also termed stage.

3.2.6 *gauging station, n*—a particular site on a stream, canal, lake, or reservoir where systematic observations of hydrologic data are obtained.

<sup>1</sup> These test methods are under the jurisdiction of ASTM Committee **D19** on Water and is the direct responsibility of Subcommittee **D19.07** on Sediments, Geomorphology, and Open-Channel Flow.

Current edition approved Nov. 1, 2021. Published January 2022. Originally approved in 1993. Last previous edition approved in 2013 as D5413 – 93 (2013). DOI: 10.1520/D5413-21.

<sup>2</sup> Sauer, V. B., and Turnipseed, D. P., “Stage Measurement at Gauging Stations,” *Techniques of Water Resources Investigations*, Book 3, Chapter A-7, U.S. Geological Survey, 2010.

<sup>3</sup> For referenced ASTM standards, visit the ASTM website, [www.astm.org](http://www.astm.org), or contact ASTM Customer Service at [service@astm.org](mailto:service@astm.org). For *Annual Book of ASTM Standards* volume information, refer to the standard’s Document Summary page on the ASTM website.

<sup>4</sup> Available from American National Standards Institute (ANSI), 25 W. 43rd St., 4th Floor, New York, NY 10036, <http://www.ansi.org>.

3.2.7 *National Geodetic Vertical Datum of 1929 (NGVD)*, *n*—a datum prior to 1973 known as mean sea level; a spheroidal datum in the conterminous United States and Canada that approximates mean sea level but does not necessarily agree with sea level at a specific location.

**4. Significance and Use**

4.1 These test methods are used to determine the gauge height or elevation of a river or other body of water above a given datum.

4.2 Water level data can serve as an easily recorded parameter, and through use of a stage-discharge relation provide an indirect value of stream discharge, often at a gauging station.

4.3 These test methods can be used in conjunction with other determinations of biological, physical, or chemical properties of waters.

**TEST METHOD A—NONRECORDING WATER-LEVEL MEASUREMENT DEVICES**

**5. Summary of Test Method**

5.1 These test methods are usually applicable to conditions where continuous records of water level or discharge are not required. However, in some situations, daily or twice daily observations from a nonrecording water-level device can provide a satisfactory record of daily water levels or discharge. Water levels obtained by the nonrecording devices described in these test methods can be used to calibrate recording water-level devices described in Test Methods B and C.

5.2 Devices included in these test methods are of two general types: those that are read directly, such as a staff gauge; and those that are read by measurement to the water surface from a fixed point, such as wire-weight, float-tape, electric-tape, point and hook gauges.

5.2.1 Staff, wire-weight, and chain gauges are commonly used as both outside auxiliary and reference gauges. Vertical and inclined-staff, float-tape, electric-tape, hook and point gauges are commonly used as inside auxiliary and reference gauges.

5.3 Documentation of observations must be manually recorded.

**6. Apparatus**

6.1 *Staff Gauges:*

6.1.1 *Vertical Staff Gauges*—Staff gauges are usually graduated porcelain-enameled plates attached to wooden piers or pilings, bridge piers, or other hydraulic structures. They may also be installed on the inside of gauging station stilling wells as inside reference gauges. They are precisely graduated, usually to 0.02 ft or 2 mm, although other markings may be used for specific applications (see Fig. 1).

6.1.2 *Inclined Staff Gauges*—Inclined staff gauges usually consist of markings on heavy timbers, steel beams, or occasionally concrete beams built partially embedded into the natural streambed slope. Since they are essentially flush with the adjoining streambed, floating debris and ice are less likely

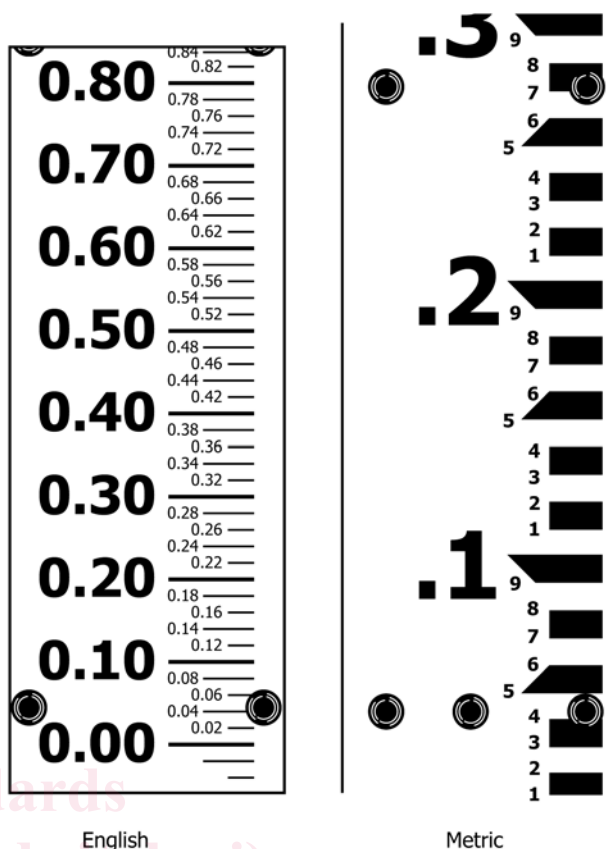

FIG. 1 Staff Gauges

to cause damage than for a vertical staff gauge. Individual graduation and marking of the installed gauges by engineering levels are required due to the variability of bank slope.

6.2 *Wire-Weight Gauge*—An instrument that is mounted on a bridge or other structure above a water body. Water levels are obtained by direct measurement of the distances between the device and the water surface. A wire-weight gauge consists of a drum wound with a single layer of cable, a bronze weight attached to the end of the cable, a graduated disk, a counter, and a check bar, all contained within a protective housing (see Fig. 2). The disk is graduated and is permanently connected to

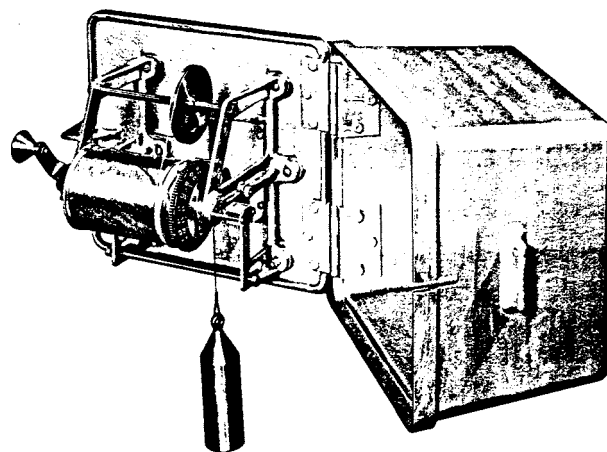

FIG. 2 Type A Wire-Weight Gauge

the counter and the shaft of the drum. The cable is guided to its position on the drum by a threading sheave. The reel is equipped with a pawl and ratchet for holding the weight at any desired elevation. A horizontally mounted check bar is mounted at the lower edge of the instrument. Differential levels are run to the check bar. When the weight is lowered to touch the check bar, readings of the counter are compared to its known elevation as a calibration procedure. The gauge is set so that when the bottom of the weight is at the water surface, the gauge height is indicated by the combined readings of the counter and the graduated disk.

6.3 *Needle Gauges*—Frequently referred to as point or hook gauges. A needle gauge consists of a vertically-mounted pointed metallic, small-diameter rod, which can be lowered until an exact contact is made with the water surface. A vernier or graduated scale is read to indicate a gauge height. A needle-type gauge offers high measurement accuracy, but requires some skill and good visibility (light conditions) in lowering and raising the device to a position where the point just pierces the water surface. These gauges are most commonly used in applications where the water surface is calm.

6.3.1 *Point Gauge*—A form of needle gauge where the tip or point approaches the water surface from above.

6.3.2 *Hook Gauge*—A form of needle gauge made in the shape of a hook, where the tip or point approaches the water surface from below (see Fig. 3). The hook gauge is easier to use in a stilling well application. As the point contacts the water surface, overhead light will reflect from a dimple on the water surface.

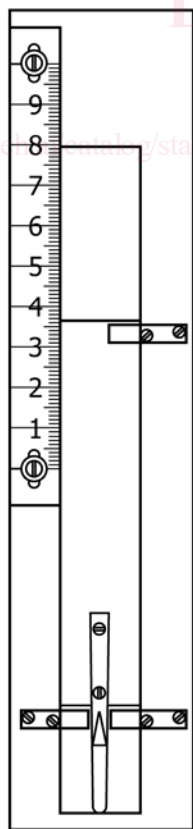

FIG. 3 Hook Gauge

6.4 *Float-Tape Gauge*—Consists of a float attached to a stainless steel graduated tape that passes over a suitable pulley with a counterweight to maintain tension. A pointer or other index is frequently fabricated as an integral part of the pulley assembly (see Fig. 4). Float-tape gauges frequently are combined with water-level recorders in a manner whereby the pulley is the stage drive wheel for the recorder.

6.5 *Electric-Tape Gauge*—Consists of a graduated steel tape and weight attached to a combined tape reel, voltmeter, datum index and electrical circuit, powered by a 4½ to 6 volt battery (see Fig. 5). The gauge frame is mounted on a shelf or bracket over the water surface, usually in a stilling well. The weight is lowered until the weight touches the water surface closing the electrical circuit that is indicated by the voltmeter. The gauge height is read on the tape at the index.

6.6 A reference point is frequently selected on a stable member of a bridge, stilling well, or other structure from which distance vertical measurements to the water surface are made by steel tape and weight. The reference point is a clearly defined location, frequently a file mark or paint mark to ensure that all readings are from the same location.

## 7. Calibration

7.1 Establish a datum. The datum may be a recognized datum such as National Geodetic Vertical Datum of 1929 (NGVD), a datum referenced to a recognized datum such as 580.00 ft NGVD 1929, a local datum, or an arbitrary datum. A datum is usually selected that will give readings of small positive numbers.

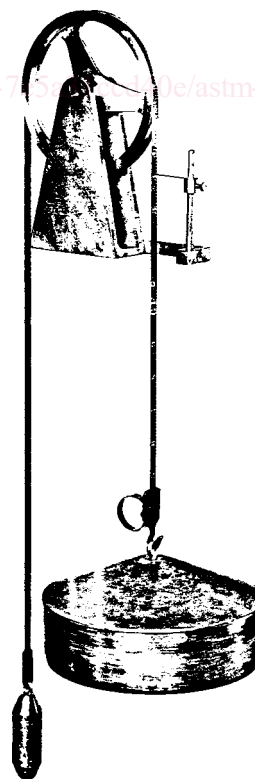

FIG. 4 Float-Type Gauge

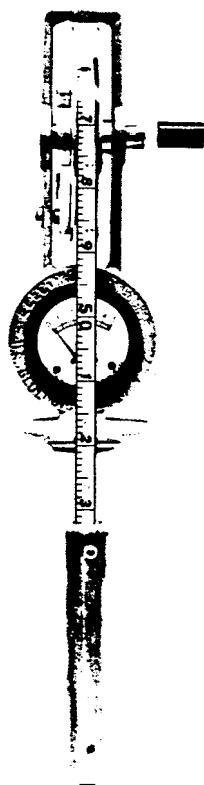

FIG. 5 Electric-Type Gauge

7.2 Establish at least three reference marks (RMs). Reference marks must be located on independent permanent structures that have a good probability of surviving a major flood or other event that may destroy the gauge. Select reference marks close enough to the water-level measuring device that the leveling circuit does not require more than two or three instrument setups to complete elevation verification. If the NGVD datum is used, determine the elevation of the reference marks by differential leveling from the nearest NGVD benchmark.

7.3 Set the gauges to correct datum by differential leveling from the reference marks. Use leveling procedures described in a surveying text or “Levels at Streamflow Gauging Stations.”<sup>5</sup>

7.4 Run levels to gauges from RMs annually for the first 3 to 5 years, then if stability is evident, a level frequency of 3 to 5 years is acceptable. Rerun levels at any time that a gauge has been disturbed or has unresolved gauge reading inconsistencies. Run levels to all RMs, reference points, index points, and to each staff gauge, and to the water surface. Read the water surface at each gauge at the time levels are run. Document differences found and changes made in a permanent record.

## 8. Procedure

8.1 Read direct reading gauges by observing the water surface on the gauge scale. Manually record this value on an appropriate form.

8.2 Gauges that require measurement from a fixed point to the water surface must follow procedures provided by manufacturers of the specific instrument.

8.3 Make a visual inspection of gauges at each reading to detect apparent damage, which could affect accuracy.

## TEST METHOD B—RECORDING WATER-LEVEL MEASUREMENT DEVICES

### 9. Summary of Test Method

9.1 These test methods are applicable where continuous unattended records of water level or discharge are required. Procedures described in Test Method A are usually used to set these recording devices to the correct datum.

9.2 Devices, generically referred to as water-level recorders, or recorders, included in these test methods must be capable of recording stage and the time and date at which the stage occurred.

9.3 Recorders may sense water level by direct mechanical connection, usually by float-counterweight and tape or cable, by gas purge manometer systems (bubble gauges), or by electronic water level sensors (pressure transducer or acoustic devices).

9.4 Recorders may retain data in graphical, analog, digital, or other format.

9.5 Recorders are available that can remain unattended for periods from one week to longer than six months.

### 10. Apparatus

#### 10.1 Types of Sensing Systems:

##### 10.1.1 Direct Reading Systems:

10.1.1.1 *Crest Stage Gauge*—A crest stage gauge is a simple sensing-recording device that is installed near a water body to record the highest water level that occurs between visits of field personnel. A wooden rod is encased in a steel or plastic pipe with holes for water to enter and rise to the outside water level. A recoverable high-water mark is left on the device by particles of ground cork that float to the highest water level (Fig. 6).

10.1.1.2 *Tape Gauge Maximum-Minimum Indicators*—These indicators include magnetic or mechanical accessories that record maximum or minimum travel of float-drive tape gauges or recorder-drive tapes.

##### 10.1.2 Mechanical Sensing Systems:

10.1.2.1 *Float Tape*—Consists of a float that floats on the water surface, usually in a stilling well, and a steel tape or cable which passes over a recorder drive pulley. A weight on the opposite end of the tape maintains tension in the tape or cable. The rise and fall of the water surface is thus directly transmitted to the recorder.

10.1.2.2 *Shaft Encoders*—These devices consist of a float-tape driven shaft and pulley assembly that converts the angular shaft position to an electronic signal compatible with electronic recorders. Analog output potentiometers and several digital format output encoding systems are available.

10.1.3 *Gas-Purge System*—This system is commonly known as a bubble gauge. A gas, usually nitrogen, is fed from a supply tank and pressure regulator through a tube and

<sup>5</sup> Kenney, T. A., “Levels at Streamflow Gauging Stations,” *Techniques of Water Resources Investigations*, Book 3, Chapter A-19, U.S. Geological Survey, 2010.

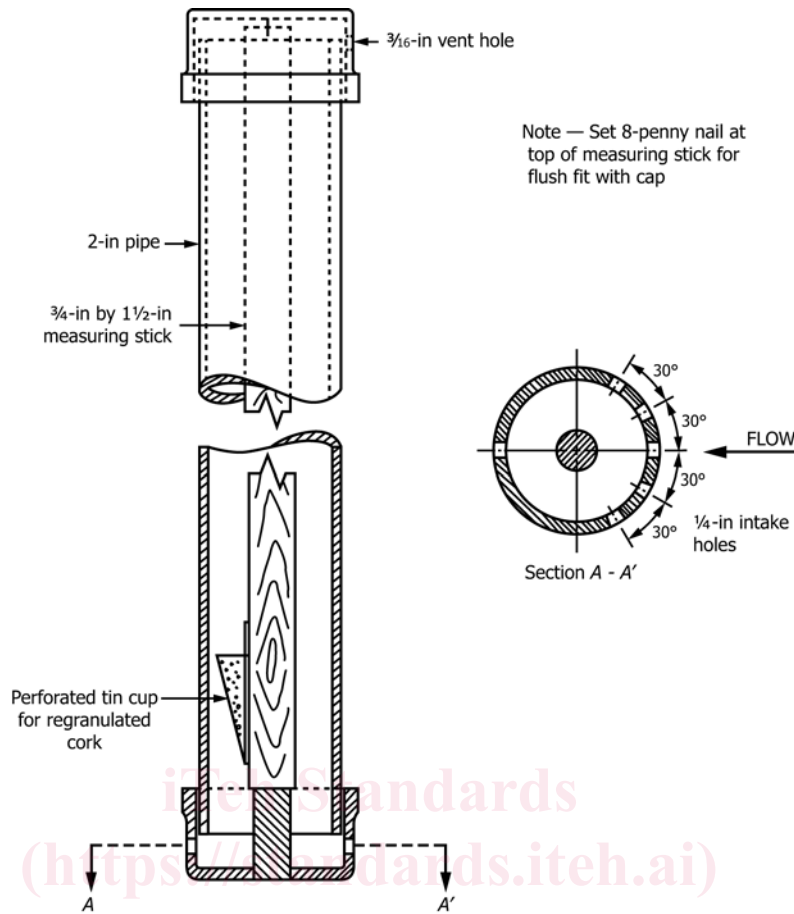

FIG. 6 Crest-Stage Gauge

bubbled freely into the water body through an orifice at a fixed location on or near the bottom of the water body. The gas pressure in the tube is equal to the piezometric head on the bubble orifice corresponding to the water level over the orifice. Several methods of sensing this line pressure and converting it to a recordable format are used (Fig. 7).

10.1.3.1 *Mercury Manometer*—The manometer assembly converts the gas purge line pressure to a shaft rotation for driving a recorder. Mercury is used because its specific gravity is 13.6 times that of water, and thus shortens the length of the

manometer. The theory and application of these devices are given in “Installation and Service Manual for U.S. Geological Survey Manometers.”<sup>6</sup> These devices are being phased out of service because of potential damage to the environment caused by mercury spills.

<sup>6</sup> Craig, J. D., “Installation and Service Manual for U.S. Geological Survey Manometers,” *Techniques of Water Resources Investigations*, Book 8, Chapter A-2, U.S. Geological Survey, 1983.

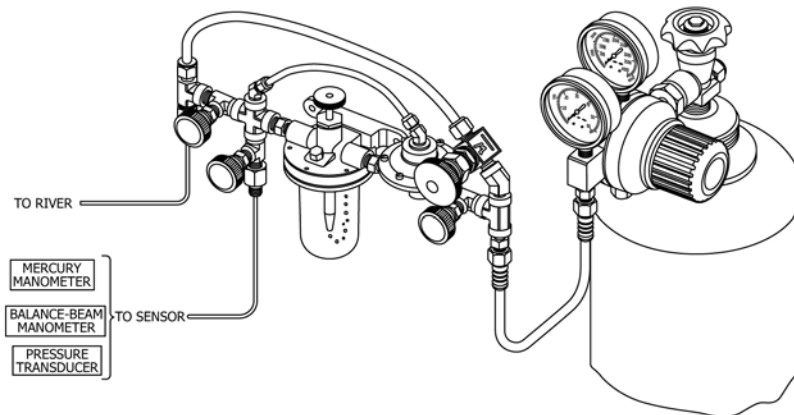

FIG. 7 Gas-Purge System