



Designation: **D1941 – 91 (Reapproved 2013) D1941 – 21**

## Standard Test Method for Open Channel Flow Measurement of Water with the Parshall Flume<sup>1</sup>

This standard is issued under the fixed designation D1941; the number immediately following the designation indicates the year of original adoption or, in the case of revision, the year of last revision. A number in parentheses indicates the year of last reapproval. A superscript epsilon ( $\epsilon$ ) indicates an editorial change since the last revision or reapproval.

### 1. Scope

1.1 This test method covers measurement of the volumetric flowrate of water and wastewater in open channels with the Parshall flume.

1.1.1 Information related to this test method can be found in ISO 1438 and ISO 4359.

1.2 The values stated in inch-pound units are to be regarded as standard. The values given in parentheses are mathematical conversions to SI units that are provided for information only and are not considered standard.

1.3 *This standard does not purport to address all of the safety concerns, if any, associated with its use. It is the responsibility of the user of this standard to establish appropriate safety, health, and environmental practices and determine the applicability of regulatory limitations prior to use.*

1.4 *This international standard was developed in accordance with internationally recognized principles on standardization established in the Decision on Principles for the Development of International Standards, Guides and Recommendations issued by the World Trade Organization Technical Barriers to Trade (TBT) Committee.*

### 2. Referenced Documents

[ASTM D1941-21](#)

<https://standards.iteh.ai/catalog/standards/sist/73afbc04-f53-41bb-9cab-26bbe26f06f4/astm-d1941-21>

2.1 *ASTM Standards:*<sup>2</sup>

[D1129 Terminology Relating to Water](#)

[D2777 Practice for Determination of Precision and Bias of Applicable Test Methods of Committee D19 on Water](#)

[D3858 Test Method for Open-Channel Flow Measurement of Water by Velocity-Area Method](#)

2.2 *ISO Standards:*<sup>3</sup>

[ISO 55555-2:1987 Liquid Flow Measurements in Open Channels—Dilution Methods for Measurement of Steady Flow—Constant Rate Injection Method](#)

[ISO 14381438:2017 Liquid Flow Measurement in Open Channels Using Thin-Plate Weirs and Venturi Flumes](#)

[ISO 43594359:2013 Liquid Flow Measurement in Open Channels—Rectangular Trapezoidal and U-shaped Flumes](#)

### 3. Terminology

3.1 ~~*Definitions—Definitions:* For definitions of terms used in this test method, refer to Terminology [D1129](#).~~

<sup>1</sup> This test method is under the jurisdiction of ASTM Committee [D19](#) on Water and is the direct responsibility of Subcommittee [D19.07](#) on Sediments, Geomorphology, and Open-Channel Flow.

Current edition approved Jan. 1, 2013Dec. 15, 2021. Published January 2013February 2022. Originally approved in 1962. Last previous edition approved in 20072013 as D1941 – 91 (2007)(2013). DOI: [10.1520/D1941-91R13-10.1520/D1941-21](#).

<sup>2</sup> For referenced ASTM standards, visit the ASTM website, [www.astm.org](http://www.astm.org), or contact ASTM Customer Service at [service@astm.org](mailto:service@astm.org). For *Annual Book of ASTM Standards* volume information, refer to the standard's Document Summary page on the ASTM website.

<sup>3</sup> Available from American National Standards Institute (ANSI), 25 W. 43rd St., 4th Floor, New York, NY 10036, <http://www.ansi.org>.

3.1.1 For definitions of terms used in this standard, refer to Terminology [D1129](#).

3.2 *Definitions of Terms Specific to This Standard:*

3.2.1 *free flow*—*flow, n*—a condition where the flowrate is governed by the state of flow at the crest overfall and hence can be determined from a single upstream depth measurement.

3.2.2 *head*—*head, n*—the height of a liquid above a specified point; ~~that is, the flume crest point.~~

3.2.2.1 Discussion—

That is, the flume crest.

3.2.3 *hydraulic jump*—*jump, n*—an abrupt transition from supercritical to subcritical flow, accompanied by considerable turbulence or gravity waves, or both.

3.2.4 *normal depth*—*depth, n*—the uniform depth of flow for a given flowrate in a long open channel of specific shape, roughness, and slope.

3.2.5 *primary instrument*—*instrument, n*—the device (~~in this case, the flume~~) that creates a hydrodynamic condition that can be sensed by the secondary instrument.

3.2.5.1 Discussion—

In this example, the primary instrument is the flume.

3.2.6 *scow float*—*float, n*—an in-stream flat for depth sensing that is usually mounted on a hinged cantilever.

3.2.7 *secondary instrument*—*instrument, n*—~~in this case,~~ a device which measures the depth of flow at an appropriate location in the flume. ~~The secondary instrument may also convert the measured depth to an indicated flow rate.~~

3.2.7.1 Discussion—

The secondary instrument may also convert the measured depth to an indicated flow rate.

3.2.8 *stilling well*—*well, n*—a small reservoir connected through a constricted passage to the main channel, that is, the flume, so that a depth measurement can be made under quiescent conditions.

3.2.9 *subcritical flow*—*flow, n*—open channel flow at a velocity less than the velocity of gravity waves in the same depth of water. ~~Subcritical flow is affected by downstream conditions, since disturbances are able to travel upstream.~~

3.2.9.1 Discussion—

Subcritical flow is affected by downstream conditions, since disturbances are able to travel upstream.

3.2.10 *submerged flow*—*flow, n*—a condition where the water stage downstream of the flume is sufficiently high to affect the flow over the flume crest and ~~hence invalidates~~ the free-flow depth-discharge ~~relation no longer applies and discharge depends on two head measurements.~~ relation.

3.2.10.1 Discussion—

Under this condition, discharge depends on two head measurements.

3.2.11 *supercritical flow*—*flow, n*—open channel flow at a velocity greater than that of gravity waves in the same depth, so disturbances cannot travel upstream, and downstream conditions do not affect the flow.

3.2.12 *throat*—*throat, n*—the constriction in a flume.

#### 4. Summary of Test Method

4.1 Parshall flumes are measuring flumes of specified geometries for which empirical relations of the form

$$Q = C H_a^n \quad (1)$$

have been established so that the flowrate,  $Q$ , can be determined from a single depth measurement,  $H_a$ , in free flow. If the flow is submerged, an addition downstream depth,  $H_b$ , must be measured and suitable adjustments made.

5. Significance and Use

5.1 Flume designs are available for throat sizes of 1 in. (2.54 cm) to 50 ft (15.2 m) which cover maximum flows of 0.2 to 3000 ft<sup>3</sup>/s (0.0057 to 85 m<sup>3</sup>/s) (1) and (2).<sup>4</sup> They can therefore be applied to a wide range of flows, with head losses that are moderate.

5.2 The flume is self-cleansing for moderate solids transport and therefore is suited for wastewater and flows with sediment.

6. Interferences

6.1 The flume is applicable only to open channel flow and is inoperative under full-pipe flow conditions.

6.2 Although the flume has substantial self-cleansing capacity, it can be clogged by debris or affected by accumulation of aquatic growth and cleaning or debris removal may be required.

7. Apparatus

7.1 A Parshall flume measuring system consists of the flume itself (primary) and a depth-measuring device (secondary). The secondary device can range from a simple scale for manual readings to an instrument which continuously senses the depth, converts it to flowrate, and provides a readout or record of instantaneous flowrate or totalized flow, or both.

7.2 The Flume:

7.2.1 Parshall flumes are characterized by throat width; dimensions and flowrates for each size are given in Fig. 1 and Table 1, respectively. The dimensions must be maintained within 2 %, because the flume is an empirical device and corrections for non-standard geometry are only estimates. The inside surface of the flume should be at least as smooth as a good quality concrete finish.

7.2.2 The measurement location for depth  $H_a$  is shown in Fig. 1. In submerged flow a second depth,  $H_b$ , must be measured in the throat as indicated. However, in the 1, 2, and 3-in. (2.54, 5.08, and 7.62-cm) flumes, this measurement is made at  $H_c$  instead, because disturbances have been observed at the  $H_b$  location in these sizes ((1) and (2)). See Fig. 2 for the relation between  $H_b$  and  $H_c$ .

7.3 Stilling Well and Connector:

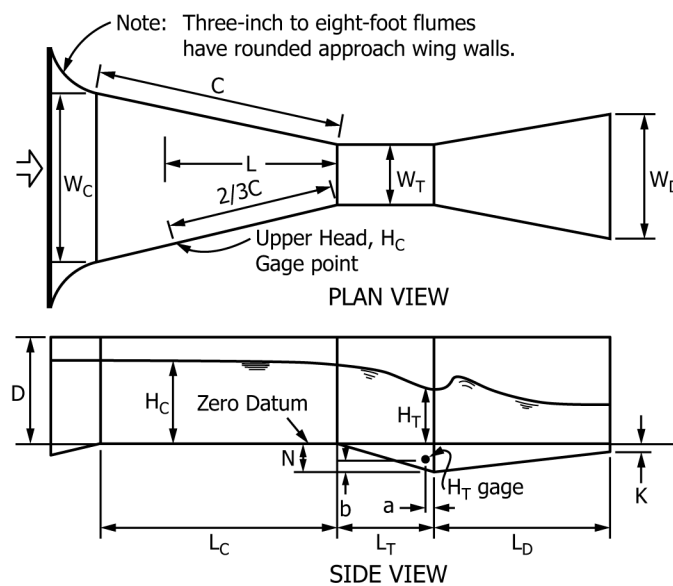
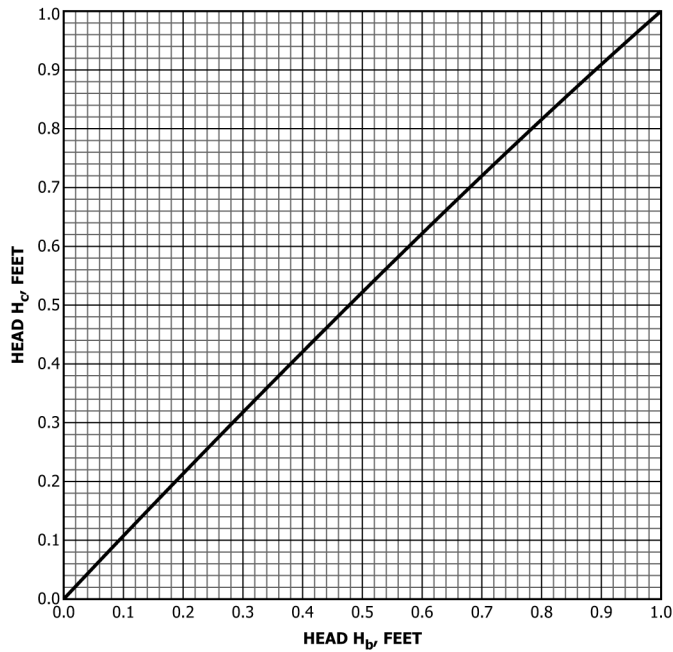

FIG. 1 Parshall Flume

<sup>4</sup> The boldface numbers in parentheses refer to a list of references at the end of this test method.



NOTE 1—1 ft = 30.48 cm

FIG. 2 Relation Between  $H_b$  and  $H_c$  for 1, 2, and 3-in. (2.54, 5.08, and 7.62-cm) flumes (Reference (2))

iTeh Standards

7.3.1 Stilling wells are recommended for accurate depth measurements; they are required when wire- or tape-supported cylindrical floats are used or when the liquid surface is fluctuating.

7.3.2 The lateral area of the stilling well is governed in part by the requirements of the depth sensor. For example, the clearance between a float and the stilling-well wall should be at least 0.1 ft (3 cm) and should be increased to 0.25 ft (7.6 cm) if the well is made of concrete or other rough material, the float diameter itself being determined in part by permissible float lag error (see [H.4.2.12.4.2](#)). Other types of depth sensors may also impose size requirements on the stilling well, and the maximum size may be limited by response lag.

<https://standards.iteh.ai/catalog/standards/sist/73afbc04-f53-41bb-9cab-26bbe26f06f4/astm-d1941-21>

7.3.3 Provision should be made for cleaning and flushing the stilling well to remove accumulated solids. It may be necessary to add a small purge flow of tap water to help keep the well and any connector pipe and the sensor parts clean. This flow should be small enough for any depth increase in the stilling well to be imperceptible.

7.3.4 The opening in the flume sidewall connecting to the stilling well either directly or through a short perpendicular pipe must have a burr-free junction with the wall. The hole or pipe must be small enough to dampen surface disturbances; an area of about 1/1000th of the stilling-well area is considered adequate for this purpose. However, the diameter should not be so small (or the pipe so long) that it is difficult to keep open or a lag is introduced in the response to changing flows (3); hole and pipe diameters of about 1/2 in. (1.3 cm) should be considered a minimum. If changes are made in pipe sizes, they should be done sufficiently removed from the flume wall that no drawdown will occur. The intake dimensions cited in this paragraph should be regarded as suggestions only.

#### 7.4 Depth-Discharge Relations:

7.4.1 *Free Flow*—The values of C and n for use with Eq 1 are given in Table 2, along with approximate limiting flowrates. The maximum submergence ratios,  $H_b/H_a$ , for which free flow will occur are:

- $H_b/H_a < 0.5$ , for 1, 2, and 3-in. (2.54, 5.08, and 7.62-cm) flumes;
- $H_b/H_a < 0.6$ , for 6 and 9-in. (15.24 and 22.86-cm) flumes;
- $H_b/H_a < 0.7$ , for 1 to 8-ft (30.48 to 243.8-cm) flumes;
- $H_b/H_a < 0.8$ , for 10 to 50-ft (304.8 to 1524.0-cm) flumes.

#### 7.4.2 Submerged Flow:

**TABLE 1 Dimensions and Capacities of Standard Parshall Flumes**

NOTE 1—Flume sizes 3 in. through 8 ft have approach aprons rising at 25 % slope and the following entrance roundings: 3 through 9 in., radius = 1.33 ft; 1 through 3 ft, radius = 1.67 ft; 4 through 8 ft, radius = 2.00 ft.

Throat, $W_T$	Widths		Axial lengths, ft			Wall Depth in Con- verging Section, $D$ , ft	Vertical distance be- low crest, ft		Converg- ing wall length $C$ , <sup>A</sup> ft	Gage Points, ft		Free-flow Capacities, ft <sup>3</sup> /s		
	Upstream end, $W_C$ , ft	Down- stream end, $W_D$ , ft	Converg- ing Section, $L_C$	Throat section, $L_T$	Diverging section, $L_D$		Dip at Throat, $N$	Lower end, of flume, $K$		$H_C$ , wall length up- stream of crest <sup>B</sup>	$H_T$		Minimum	Maximum
1 in.	0.549	0.305	1.17	0.250	0.67	0.5–0.75	0.094	0.062	1.19	0.79	0.026	0.042	0.005	0.15
2 in.	0.700	0.443	1.33	0.375	0.83	0.50–0.83	0.141	0.073	1.36	0.91	0.052	0.083	0.01	0.30
3 in.	0.849	0.583	1.50	0.500	1.00	1.00–2.00	0.188	0.083	1.53	1.02	0.083	0.125	0.03	1.90
6 in.	1.30	1.29	2.00	1.00	2.00	2.0	0.375	0.25	2.36	1.36	0.167	0.25	0.05	3.90
9 in.	1.88	1.25	2.83	1.00	1.50	2.5	0.375	0.25	2.88	1.93	0.167	0.25	0.09	8.90
1.0 ft	2.77	2.00	4.41	2.0	3.0	3.0	0.75	0.25	4.50	3.00	0.167	0.25	0.11	16.1
1.5 ft	3.36	2.50	4.66	2.0	3.0	3.0	0.75	0.25	4.75	3.17	0.167	0.25	0.15	24.6
2.0 ft	3.96	3.00	4.91	2.0	3.0	3.0	0.75	0.25	5.00	3.33	0.167	0.25	0.42	33.1
3.0 ft	5.16	4.00	5.40	2.0	3.0	3.0	0.75	0.25	5.50	3.67	0.167	0.25	0.61	50.4
4.0 ft	6.35	5.00	5.88	2.0	3.0	3.0	0.75	0.25	6.00	4.00	0.167	0.25	1.30	67.9
5.0 ft	7.55	6.00	6.38	2.0	3.0	3.0	0.75	0.25	6.50	4.33	0.167	0.25	1.60	85.6
6.0 ft	8.75	7.00	6.86	2.0	3.0	3.0	0.75	0.25	7.0	4.67	0.167	0.25	2.60	103.5
7.0 ft	9.95	8.00	7.35	2.0	3.0	3.0	0.75	0.25	7.5	5.0	0.167	0.25	3.00	121.4
8.0 ft	11.15	9.00	7.84	2.0	3.0	3.0	0.75	0.25	8.0	5.33	0.167	0.25	3.50	139.5
10 ft	15.60	12.00	14.0	3.0	6.0	4.0	1.12	0.50	9.0	6.00	...	...	6	300
12 ft	18.40	14.67	16.0	3.0	8.0	5.0	1.12	0.50	10.0	6.67	...	...	8	520
15 ft	25.0	18.33	25.0	4.0	10.0	6.0	1.50	0.75	11.5	7.67	...	...	8	900
20 ft	30.0	24.00	25.0	6.0	12.0	7.0	2.25	1.00	14.0	9.33	...	...	10	1340
25 ft	35.0	29.33	25.0	6.0	13.0	7.0	2.25	1.00	16.5	11.00	...	...	15	1660
30 ft	40.4	34.67	26.0	6.0	14.0	7.0	2.25	1.00	19.0	12.67	...	...	15	1990
40 ft	50.8	45.33	27.0	6.0	16.0	7.0	2.25	1.00	24.0	16.00	...	...	20	2640
50 ft	60.8	56.67	27.0	6.0	20.0	7.0	2.25	1.00	29.0	19.33	...	...	25	3280

<sup>A</sup> For sizes 1 to 8 ft,  $C = W_T/2 + 4$  ft.

<sup>B</sup>  $H_C$  located  $\frac{2}{3} C$  distance from crest for all sizes; distance is wall length, not axial.

7.4.2.1 Discharge rates for submerged-flow conditions are given for 1, 2, 3, 6, and 9-in. (2.54, 5.08, 7.62, 15.24, and 22.86-cm) flumes in [Table 3](#), [Table 4](#), [Table 5](#), [Table 6](#), and [Table 7](#) ([Table 8](#), [Table 9](#), [Table 10](#), [Table 11](#), and [Table 12](#)), which were compiled from published curves (2).

7.4.2.2 For all larger flumes, that is, 1 to 50 ft (30.48 to 1524 cm) throat widths, flowrates under submerged-flow conditions are given as corrections to be subtracted from the free-flow discharge at the same  $H_a$ . These corrections are found in [Table 13](#), [Table 14](#), [Table 15](#), and [Table 16](#) ([Table 17](#), [Table 14](#), [Table 18](#), and [Table 16](#)), which were compiled from published curves (2).

7.4.2.3 It is recommended that submergence be avoided if possible and that ratios not be allowed to exceed 0.95.

### 7.5 Installation Requirements:

7.5.1 It is highly desirable that the Parshall flume installation be designed for free flow (3). The depth-discharge relations for free flow are more accurate than those for submerged flow, particularly at high submergence ratios. Further, the secondary instrumentation for free flow is simpler and more readily available. Design for free flow requires an estimate of the normal depth of flow in the channel downstream of the flume and the assumption that the resulting surface elevation prevails approximately at the  $H_b$  location. Design examples are available in the References.

7.5.2 The flow entering the flume should be tranquil and uniformly distributed across the channel. For this purpose, *uniform* velocity distribution can be defined as that associated with fully developed flow in a long, straight, moderately smooth channel. As a general guideline, a straight upstream approach length of 10 to 20 times the throat width will meet this entrance condition. The adequacy of the approach flow must be demonstrated on a case-by-case basis using current-meter traverses, experience with similar situations, or analytical approximations.

7.5.3 If the approach flow is supercritical, the installation should be designed so that a hydraulic jump is formed at a distance upstream of at least  $30 H_a$ . If the existence of the hydraulic jump closer to the flume is unavoidable, the adequacy of the entering flow should be demonstrated as in 7.5.2.

**TABLE 2 Free-Flow Values of  $C$  and  $n$  for Parshall Flumes  
(See Eq 1)**

Throat Width		$C^A$			$n$	$Q, \text{min}^B$		$Q, \text{max}^B$	
ft-in.	cm	inch-pound	SI	ft <sup>3</sup> /s		m <sup>3</sup> × 10 <sup>3</sup> /s	ft <sup>3</sup> /s	m <sup>3</sup> /s	
0-1	2.54	0.338	0.0479	1.55	0.01	0.28	0.2	0.0057	
0-2	5.08	0.676	0.0959	1.55	0.02	0.56	0.5	0.014	
0-3	7.62	0.992	0.141	1.55	0.03	0.85	1.1	0.031	
0-6	15.24	2.06	0.264	1.58	0.05	1.42	3.9	0.11	
0-9	22.80	3.07	0.393	1.53	0.09	2.55	8.9	0.25	
1-0	30.48	4.00	0.624	1.522	0.11	3.1	16.1	0.46	
1-6	45.72	6.00	0.887	1.538	0.15	4.2	24.6	0.69	
2-0	60.96	8.00	1.135	1.550	0.42	11.9	38.1	0.93	
3-0	91.44	12.00	1.612	1.566	0.61	17.3	50.4	1.42	
4-0	121.92	16.00	2.062	1.578	1.3	36.8	67.9	1.92	
5-0	152.40	20.00	2.500	1.587	1.6	45.3	85.6	2.42	
6-0	182.88	24.00	2.919	1.595	2.6	73.6	103.5	2.93	
7-0	213.36	28.00	3.337	1.601	3.0	85.0	121.4	3.44	
8-0	243.84	32.00	3.736	1.607	3.5	99.1	139.5	3.95	
10-0	304.8	39.38	4.709	1.6	6	170	200	5.6	
12-0	365.8	46.75	5.590	1.6	8	227	350	9.9	
19-0	457.2	57.81	6.912	1.6	8	227	600	17.0	
20-0	609.6	76.25	9.117	1.6	10	283	1000	28.3	
25-0	762.0	94.69	11.32	1.6	15	425	1200	34.0	
30-0	914.4	113.13	13.53	1.6	15	425	1500	42.5	
40-0	1219.2	150.00	17.94	1.6	20	566	2000	56.6	
50-0	1524.0	186.88	22.35	1.6	25	708	3000	84.9	

<sup>A</sup> Listed values of  $C$  should be used in Eq 1 with  $H_a$  in feet to obtain flowrate in cubic feet per second. Listed values of  $C$  (metric) should be used with  $H_a$  in centimetres to obtain flowrate in litres per second.

<sup>B</sup> From Ref (1).

ASTM D1941-21

7.5.4 The flume should be constructed and installed so that the floor of the converging section is level to within a slope not to exceed 0.01 ft in any dimension, or a re-rating is necessary.

**TABLE 3 Flume, 1-in. (2.54-cm), Submerged—Flowrate, ft<sup>3</sup>/s**

Sub-merged, %	$H_a$ , ft															
	0.05	0.06	0.08	0.10	0.15	0.20	0.25	0.30	0.35	0.40	0.45	0.50	0.55	0.60	0.70	0.80
50	0.0033	0.0044	0.0067	0.0095	0.0180	0.028	0.039	0.052	0.066	0.082	0.097	...	...	...	...	...
55	0.0032	0.0043	0.0066	0.0094	0.0180	0.028	0.038	0.052	0.065	0.081	0.096	...	...	...	...	...
60	0.0032	0.0042	0.0065	0.0093	0.0179	0.027	0.038	0.051	0.064	0.079	0.094	...	...	...	...	...
65	0.0031	0.0041	0.0064	0.0090	0.0173	0.026	0.037	0.050	0.061	0.076	0.091	...	...	...	...	...
70	0.0030	0.0040	0.0062	0.0087	0.0165	0.025	0.035	0.047	0.058	0.072	0.087	...	...	...	...	...
75	...	0.0038	0.0059	0.0083	0.0156	0.024	0.033	0.044	0.055	0.068	0.081	0.096	...	...	...	...
80	...	0.0036	0.0055	0.0077	0.0145	0.022	0.031	0.040	0.051	0.063	0.074	0.088	0.100	...	...	...
85	...	0.0032	0.0050	0.0069	0.0130	0.020	0.028	0.036	0.045	0.056	0.066	0.077	0.090	0.100	...	...
90	...	...	0.0042	0.0060	0.0112	0.017	0.024	0.031	0.038	0.046	0.055	0.064	0.074	0.083	...	...
95	...	...	0.0034	0.0048	0.0089	0.014	0.018	0.024	0.030	0.037	0.042	0.050	0.056	0.062	0.075	0.090

**TABLE 4 Flume, 2-in. (5.08-cm), Submerged—Flowrate, ft<sup>3</sup>/s**

Sub-merged, %	$H_a$ , ft															
	0.06	0.10	0.15	0.20	0.25	0.30	0.35	0.40	0.45	0.50	0.55	0.60	0.70	0.80	0.90	1.00
50	0.0086	0.0189	0.0350	0.0554	0.080	0.103	0.137	0.165	0.200	0.230	0.271	0.314	...	...	...	...
55	0.0086	0.0188	0.0350	0.0550	0.079	0.103	0.136	0.163	0.198	0.229	0.270	0.314	0.382	...	...	...
60	0.0085	0.0185	0.0345	0.0549	0.078	0.102	0.134	0.161	0.194	0.226	0.268	0.312	0.377	...	...	...
65	0.0083	0.0182	0.0340	0.0534	0.077	0.101	0.132	0.158	0.190	0.223	0.263	0.307	0.371	...	...	...
70	0.0080	0.0175	0.0332	0.0520	0.075	0.098	0.129	0.154	0.186	0.216	0.254	0.296	0.361	...	...	...
75	0.0077	0.0164	0.0312	0.0498	0.072	0.093	0.123	0.148	0.179	0.207	0.242	0.282	0.344	...	...	...
80	0.0071	0.0152	0.0289	0.0458	0.067	0.087	0.114	0.139	0.167	0.193	0.228	0.261	0.326	0.396	...	...
85	...	0.0138	0.0258	0.0409	0.060	0.080	0.101	0.126	0.151	0.176	0.203	0.235	0.300	0.358	...	...
90	...	0.0117	0.0212	0.0346	0.049	0.067	0.087	0.104	0.129	0.150	0.177	0.200	0.259	0.315	0.369	...
95	...	0.0088	0.0158	0.0244	0.035	0.047	0.064	0.078	0.092	0.111	0.130	0.150	0.198	0.250	0.300	0.350

**TABLE 5 Flume, 3-in. (7.62-cm), Submerged—Flowrate, ft<sup>3</sup>/s**

Sub-merged, %	$H_a$ , ft																	
	0.12	0.16	0.20	0.25	0.30	0.35	0.40	0.45	0.50	0.55	0.60	0.70	0.80	0.90	1.0	1.2	1.4	1.6
50	0.037	0.057	0.082	0.117	0.156	0.195	0.240	0.287	0.335	0.397	0.450	0.562	0.700	0.841	0.977	1.31	...	...
55	0.037	0.057	0.082	0.117	0.156	0.194	0.239	0.286	0.334	0.394	0.448	0.561	0.696	0.836	0.974	1.31	...	...
60	0.037	0.057	0.082	0.116	0.155	0.192	0.238	0.285	0.333	0.390	0.443	0.559	0.686	0.826	0.967	1.29	...	...
65	0.037	0.057	0.082	0.115	0.154	0.191	0.236	0.282	0.331	0.383	0.436	0.557	0.680	0.817	0.958	1.27	...	...
70	0.036	0.056	0.080	0.113	0.150	0.188	0.230	0.277	0.325	0.374	0.425	0.545	0.665	0.800	0.935	1.25	...	...
75	0.036	0.055	0.077	0.108	0.144	0.182	0.221	0.264	0.312	0.359	0.408	0.520	0.642	0.763	0.900	1.19	1.49	...
80	0.034	0.052	0.073	0.101	0.136	0.171	0.206	0.247	0.293	0.339	0.383	0.488	0.604	0.712	0.841	1.12	1.41	...
85	0.031	0.047	0.066	0.092	0.123	0.153	0.188	0.223	0.263	0.309	0.350	0.439	0.545	0.651	0.758	1.00	1.28	...
90	...	0.041	0.057	0.081	0.104	0.134	0.163	0.192	0.225	0.264	0.304	0.379	0.465	0.562	0.653	0.853	1.09	1.33
95	...	0.033	0.045	0.062	0.081	0.098	0.125	0.148	0.174	0.198	0.228	0.290	0.355	0.422	0.500	0.648	0.815	0.988

## 7.6 Secondary Instrumentation:

7.6.1 A minimal secondary system for continuous monitoring would contain a depth-sensing device and a depth indicator or recorder from which the user could determine flowrates from the depth-discharge relations. Optionally, the secondary system could convert the measured depth to an indicated or recorded flowrate, or both, and totalized flow, and further could transmit the information electrically or pneumatically to a central location.

7.6.2 Continuous depth measurements can be made with several types of sensors including, but not restricted to, the following:

7.6.2.1 Floats, such as, cylindrical (3) and scow types;

7.6.2.2 Pressure sensors, such as, bubble types (3) and (4), diaphragm gages;

7.6.2.3 Acoustic sensors;

7.6.2.4 Electrical sensors, such as, resistance, capacitance, and oscillating probes.