



Designation: ~~C1292—16~~ C1292 – 22

# Standard Test Method for Shear Strength of Continuous Fiber-Reinforced Advanced Ceramics at Ambient Temperatures<sup>1</sup>

This standard is issued under the fixed designation C1292; the number immediately following the designation indicates the year of original adoption or, in the case of revision, the year of last revision. A number in parentheses indicates the year of last reappraisal. A superscript epsilon ( $\epsilon$ ) indicates an editorial change since the last revision or reappraisal.

## 1. Scope

1.1 This test method covers the determination of shear strength of continuous fiber-reinforced ceramic composites (CFCCs) at ambient temperature. The test methods addressed are (1) the compression of a double-notched test specimen to determine interlaminar shear strength, and (2) the Iosipescu test method to determine the shear strength in any one of the material planes of laminated composites. Test specimen fabrication methods, testing modes (load or displacement control), testing rates (load rate or displacement rate), data collection, and reporting procedures are addressed.

1.2 This test method is used for testing advanced ceramic or glass matrix composites with continuous fiber reinforcement having ~~uni-directional (1-D) or bi-directional (2-D)~~ unidirectional (1D) or bidirectional (2D) fiber architecture. This test method does not address composites with ~~(3-D)~~ 3D fiber architecture or discontinuous fiber-reinforced, whisker-reinforced, or particulate-reinforced ceramics.

1.3 The values stated in SI units are to be regarded as the standard and are in accordance with **IEEE/ASTM SI 10**.

1.4 *This standard does not purport to address all of the safety concerns, if any, associated with its use. It is the responsibility of the user of this standard to establish appropriate ~~safety~~ safety, health, and health environmental practices and determine the applicability of regulatory limitations prior to use.* Specific hazard statements are given in **8.1** and **8.2**.

1.5 *This international standard was developed in accordance with internationally recognized principles on standardization established in the Decision on Principles for the Development of International Standards, Guides and Recommendations issued by the World Trade Organization Technical Barriers to Trade (TBT) Committee.*

## 2. Referenced Documents

### 2.1 ASTM Standards:<sup>2</sup>

- [C1145 Terminology of Advanced Ceramics](#)
- [D695 Test Method for Compressive Properties of Rigid Plastics](#)
- [D3846 Test Method for In-Plane Shear Strength of Reinforced Plastics](#)
- [D3878 Terminology for Composite Materials](#)
- [D5379/D5379M Test Method for Shear Properties of Composite Materials by the V-Notched Beam Method](#)
- [E4 Practices for Force Calibration and Verification of Testing Machines](#)
- [E6 Terminology Relating to Methods of Mechanical Testing](#)

<sup>1</sup> This test method is under the jurisdiction of ASTM Committee C28 on Advanced Ceramics and is the direct responsibility of Subcommittee C28.07 on Ceramic Matrix Composites.

Current edition approved Jan. 15, 2016; Feb. 1, 2022. Published February 2016; February 2022. Originally approved in 1995. Last previous edition approved in 2016 as C1292 – 10; C1292 – 16. DOI: 10.1520/C1292-16.10.1520/C1292-22.

<sup>2</sup> For referenced ASTM standards, visit the ASTM website, www.astm.org, or contact ASTM Customer Service at service@astm.org. For *Annual Book of ASTM Standards* volume information, refer to the standard's Document Summary page on the ASTM website.

[E122 Practice for Calculating Sample Size to Estimate, With Specified Precision, the Average for a Characteristic of a Lot or Process](#)

[E177 Practice for Use of the Terms Precision and Bias in ASTM Test Methods](#)

[E337 Test Method for Measuring Humidity with a Psychrometer \(the Measurement of Wet- and Dry-Bulb Temperatures\)](#)

[E691 Practice for Conducting an Interlaboratory Study to Determine the Precision of a Test Method](#)

[IEEE/ASTM SI 10 American National Standard for Use of the International System of Units \(SI\): The Modern Metric System](#)  
[Metric Practice](#)

### 3. Terminology

#### 3.1 Definitions:

3.1.1 The definitions of terms relating to shear strength testing appearing in Terminology [E6](#) apply to the terms used in this test method. The definitions of terms relating to advanced ceramics appearing in Terminology [C1145](#) apply to the terms used in this test method. The definitions of terms relating to fiber-reinforced composites appearing in Terminology [D3878](#) apply to the terms used in this test method. Additional terms used in conjunction with this test method are defined in the following.

3.1.2 *advanced ceramic*—~~engineered high-performance~~ a highly engineered, high-performance, predominately nonmetallic, inorganic, ceramic material having specific functional attributes.

3.1.3 *continuous fiber-reinforced ceramic matrix composite (CFCC)*—a ceramic matrix composite in which the reinforcing phase(s) consists of a continuous fiber, continuous filaments, fibers, yarn, braid, or a knitted or woven fabric.

3.1.4 *shear breaking force (F)*—maximum force required to fracture a shear-loaded test specimen.

3.1.5 *shear strength (F/L<sup>2</sup>)*—maximum shear stress that a material is capable of sustaining. Shear strength is calculated from breaking force in shear and shear area.

### 4. Summary of Test Method

4.1 This test method addresses two methods to determine the shear strength of CFCCs: (1) the compression test method to determine interlaminar shear strength of a double-notched test specimen,<sup>3</sup> and (2) the Iosipescu test method to determine the shear strength in any one of the material planes of laminated CFCCs.<sup>4</sup>

4.1.1 *Shear Test by Compression Loading of Double-Notched Test Specimens*—The interlaminar shear strength of CFCCs, as determined by this method, is measured by compressively loading in compression a double-notched test specimen of uniform width. Failure of the test specimen occurs by shear between two centrally located notches—~~notch tips~~ machined halfway through the thickness and spaced a fixed distance apart on opposing faces. Schematics of the test setup and the test specimen are shown in [Fig. 1](#) and [Fig. 2](#).

4.1.2 *Shear Test By the Iosipescu Method*—The shear strength of one of the different material shear planes of laminated CFCCs may be determined by loading a test specimen in the form of a rectangular flat strip with symmetric centrally located V-notches using a mechanical testing machine and a four-point asymmetric fixture. The loading can be idealized as asymmetric flexure by the shear and bending diagrams in [Fig. 3](#). Failure of the test specimen occurs by shear between the V-notches. Different test specimen configurations are addressed for this test method. Schematics of the test setup and test specimen are shown in [Fig. 4](#) and [Fig. 5](#). The determination of shear properties of polymer matrix composites by the Iosipescu method has been presented in Test Method [D5379/D5379M](#).

### 5. Significance and Use

5.1 Continuous fiber-reinforced ceramic composites ~~are can be~~ candidate materials for structural applications requiring high degrees of wear and corrosion resistance, and damage tolerance at high temperatures.

5.2 Shear tests provide information on the strength and deformation of materials under shear stresses.

<sup>3</sup> Whitney, J., M., "Stress Analysis of the Double Notch Shear Specimen," Proceedings of the American Society for Composites, 4th Technical Conference, Blacksburg Virginia, Oct. 3-5, 1989, Technomic Publishing Co., p. 325.

<sup>4</sup> Iosipescu, N., "New Accurate Procedure for Shear Testing of Metals," *Journal of Materials*, Vol 2, No. 3, Sept-1967, pp. 537-566.

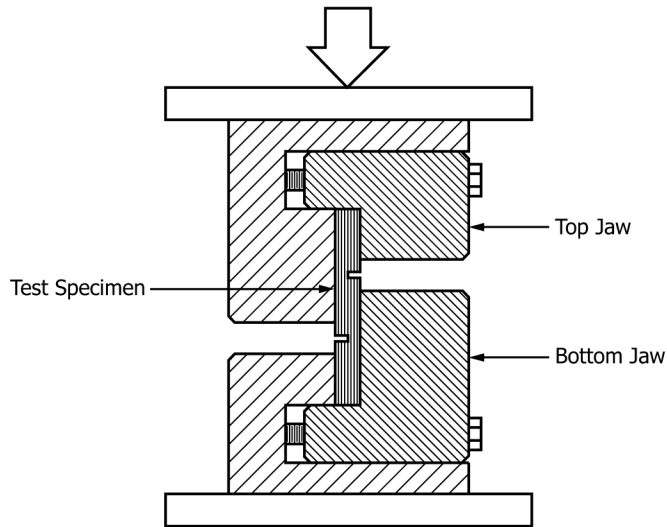
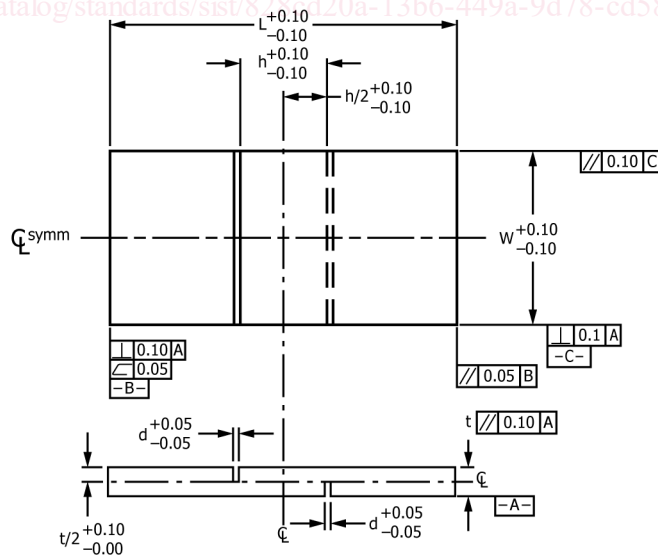
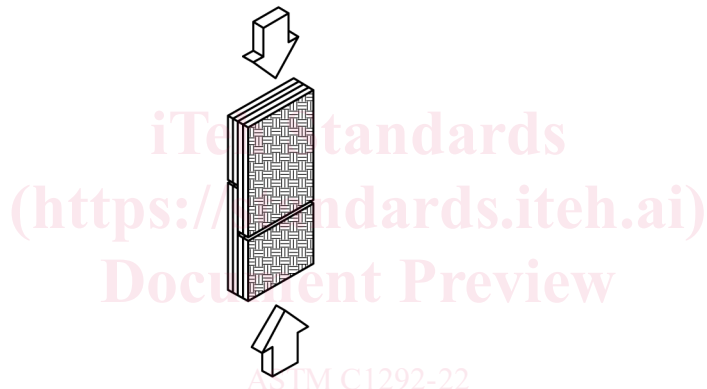
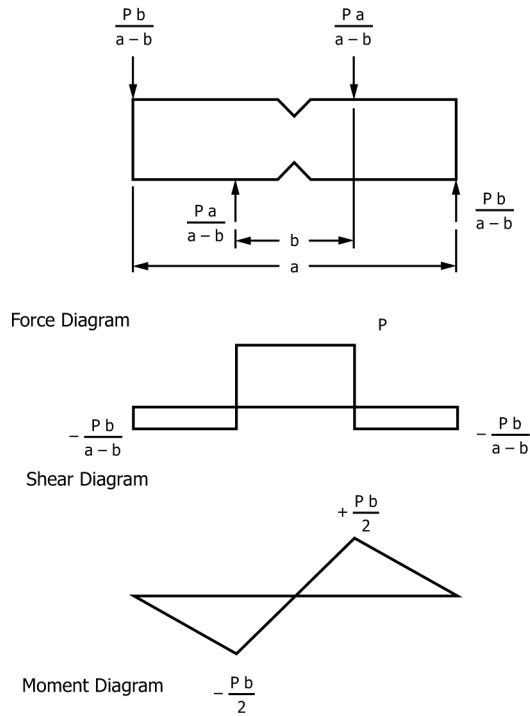

FIG. 1 Schematic of Test Fixture for the Double-Notched Compression Test Specimen



NOTE 1—All tolerances are in millimeters.

FIG. 2 Schematic of Double-Notched Compression Test Specimen



NOTE 1—The forces are depicted as being concentrated, whereas they are actually distributed over an area.

FIG. 3 Idealized Force, Shear, and Moment Diagrams for Asymmetric Four-Point Loading

iteh Standards  
<https://standards.iteh.ai>  
 Document Preview

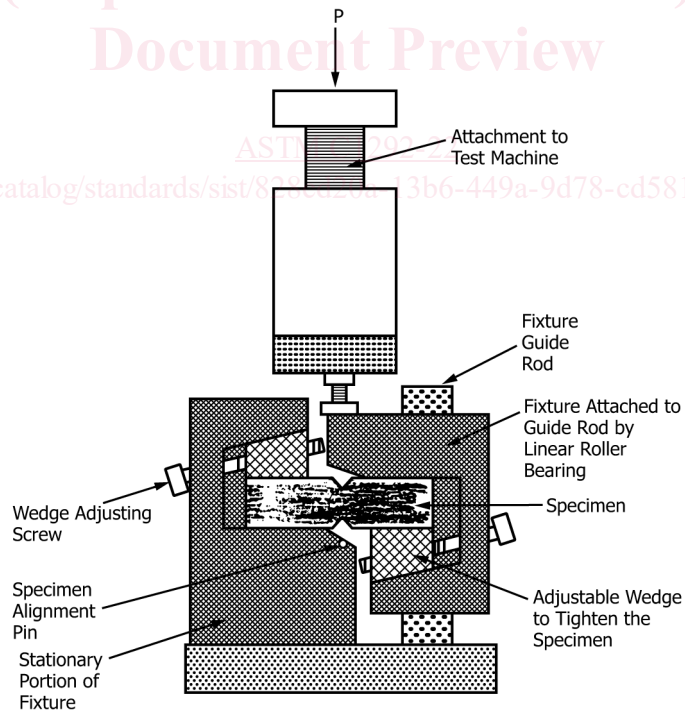
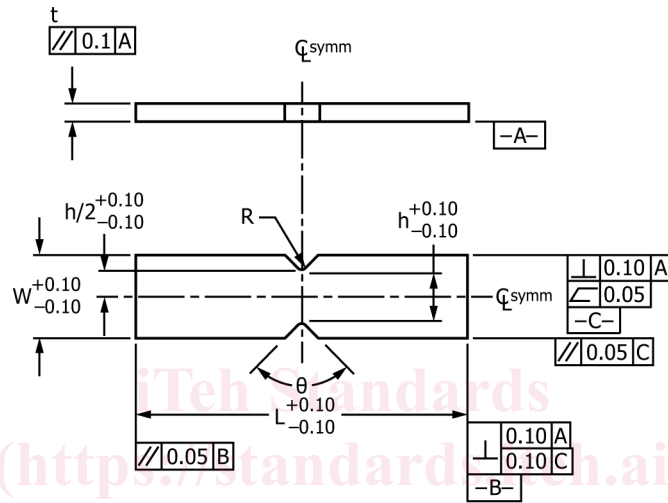
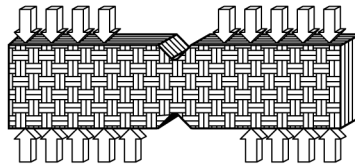

FIG. 4 Schematic of Test Fixture for the Iosipescu Test

5.3 This test method may be used for material development, material comparison, quality assurance, characterization, and design data generation.



NOTE 1—All tolerances are in millimeters.

FIG. 5 Schematic of the Iosipescu Specimen

ASTM C1292-22

<https://standards.iteh.ai/catalog/standards/sist/828cd20a-13b6-449a-9d78-cd58180e1f2f/astm-c1292-22>

5.4 For quality control purposes, results derived from standardized shear test specimens may be considered indicative of the response of the material from which they were taken for given primary processing conditions and post-processing heat treatments.

## 6. Interferences

6.1 Test environment (vacuum, inert gas, ambient air, etc.) including moisture content (for example, relative humidity), may have an influence on the measured shear strength. In particular, the behavior of materials susceptible to slow crack growth fracture will be strongly influenced by test environment and testing rate. Testing to evaluate the maximum strength potential of a material shall be conducted in inert environments or at sufficiently rapid testing rates, or both, so as to minimize slow crack growth effects. Conversely, testing can be conducted in environments and testing modes and rates representative of service conditions to evaluate material performance under those conditions. When testing is conducted in uncontrolled ambient air with the intent of evaluating maximum strength potential, relative humidity and temperature must be monitored and reported. Testing at humidity levels >65 % RH is not recommended and any deviations from this recommendation must be reported.

6.2 Preparation of test specimens, although normally not considered a major concern with CFCCs, can introduce fabrication flaws which may have pronounced effects on the mechanical properties and behavior (for example, shape and level of the resulting force-displacement curve and shear strength). Machining damage introduced during test specimen preparation can be either a random interfering factor in the determination of shear strength of pristine material, or an inherent part of the strength characteristics to be measured. Universal or standardized test methods of surface preparation do not exist. Final machining steps may may or may not negate machining damage introduced during the initial machining. Thus, test specimen fabrication history may play an important role in the measured strength distributions and shall be reported.

6.3 Bending in uniaxially loaded shear tests can cause or promote nonuniform stress distributions that may alter the desired uniform state of stress during the test.

6.4 Fractures that initiate outside the uniformly stressed gauge section of a test specimen may be due to factors such as localized stress concentrations, extraneous stresses introduced by improper loading configurations, or strength-limiting features in the microstructure of the specimen. Such non-gauge section fractures will normally constitute invalid tests.

6.5 For the conduction of the Iosipescu test, thin test specimens (width to thickness ratio of more than ten) may suffer from splitting and instabilities rendering in turn invalid test results.

6.6 For the evaluation of the interlaminar shear strength by the compression of a double-notched test specimen, the distance between the notches in the specimen has an effect on the maximum force and therefore on the shear strength.<sup>5</sup> It has been found that the stress distribution in the test specimen is independent of the distance between the notches when the notches are far apart. However, when the distance between the notches is such that the stress fields around the notches interact, the measured interlaminar shear strength increases. Because of the complexity of the stress field around each notch and its dependence on the properties and homogeneity of the material, it is recommended to conduct a series of tests on test specimens with different spacing between the notches to determine their effect on the measured interlaminar shear strength.

6.7 For the evaluation of the interlaminar shear strength by the compression of a double-notched test specimen, excessive clamping force with the jaws will reduce the stress concentration around the notches and therefore artificially increase the measured interlaminar shear strength. Because the purpose of the jaws is to maintain the specimen in place and to prevent buckling, avoid overtightening the jaws.

6.8 Most test fixtures incorporate an alignment mechanism in the form of a guide rod and a linear roller bearing. Excessive free play or excessive friction in this mechanism may introduce spurious moments that will alter the ideal loading conditions.

## 7. Apparatus

7.1 *Testing Machines*—The testing machine shall be in conformance with Practices E4. The forces used in determining shear strength shall be accurate within  $\pm 1\%$  at any force within the selected force range of the testing machine as defined in Practices E4.

<https://standards.iteh.ai/catalog/standards/sist/828cd20a-13b6-449a-9d78-cd58180e1f2f/astm-c1292-22>

7.2 *Data Acquisition*—~~At the minimum, autographic records of applied force and cross-head displacement versus time shall be obtained. Either analog chart recorders or~~ Either digital data acquisition systems ~~or analog chart recorders~~ may be used for this purpose as recording devices, although a digital record is recommended for ease of later data analysis. ~~Ideally, an analog chart recorder or plotter shall be used in conjunction with the digital data acquisition system to provide an immediate record of the test as a supplement to the digital record.~~ Recording devices must be accurate to  $\pm 1\%$  of full scale and shall have a minimum data acquisition rate of 10 Hz, with a response of 50 Hz deemed more than sufficient.

7.3 *Dimension-Measuring Devices*—Micrometers and other devices used for measuring linear dimensions must be accurate and precise to at least 0.01 mm.

### 7.4 Test Fixtures:

7.4.1 ~~Double-notched~~ *Double-Notched Compression Test Specimen*—The test fixture consists of a stationary element mounted on a base plate, an element that attaches to the crosshead of the testing machine, and two jaws to fix the test specimen in position. A schematic description of the test fixture is shown in Fig. 1.<sup>5</sup> A supporting jig conforming to the geometry of that shown in Fig. 1 of Test Method D3846 or Fig. 4 of Test Method D695 may also be used.

<sup>5</sup> Lara-Curzio, E., “Properties of Continuous Fiber-Reinforced Ceramic Matrix Composites for Gas Turbine Applications,” Chapter 22.22 in *Ceramic Gas Turbine Design and Test Experience: Progress in Ceramic Gas Turbine Development*, Vol. 2, Ed. M. van Roode, M. K. Ferber, and D. W. Richerson. ASME Richerson, Eds., ASME, 2003, pp. 441–491.

**TABLE 1 Recommended Dimensions for Double-Notched Compression Specimen**

Dimension	Description	Value, mm
$L$	Specimen length	30.00
$h$	<del>Distance between notches</del>	<del>6.00</del>
$h$	Distance between notches	6.00
$W$	Specimen width	15.00
$d$	<del>Notch width</del>	<del>0.50</del>
$d$	Notch width	0.50
$t$	Specimen thickness	...

7.4.2 *Iosipescu Test Specimen*—The test fixture shall be a four-point asymmetric flexure fixture shown schematically in Fig. 4.<sup>6</sup> This test fixture consists of a stationary element mounted on a base plate, plate and a movable element capable of vertical translation guided by a stiff post. The movable element attaches to the cross-head, crosshead of the testing machine. Each element clamps half of the test specimen into position with a wedge action grip able to compensate for minor width variations of the test specimen. A span of 13 mm is left unsupported between test fixture halves. An alignment tool is recommended to ensure that the test specimen notch is aligned with the line-of-action of the loading fixture.

## 8. Hazards

8.1 During the conduct of this test method, the possibility of flying fragments of broken test material may be high. The brittle nature of advanced ceramics and the release of strain energy contribute to the potential release of uncontrolled fragments upon fracture. Means for containment and retention of these fragments for later fractographic reconstruction and analysis is highly recommended.

8.2 Exposed fibers at the edges of CFCC test specimens present a hazard due to the sharpness and brittleness of the ceramic fiber. All persons required to handle these materials shall be well informed of these conditions and the proper handling techniques.

## 9. Test Specimens

### 9.1 Test Specimen Geometry:

9.1.1 *Double-Notched Compression Test Specimen*—The test specimens shall conform to the shape and tolerances shown in Fig. 2. The specimen consists of a rectangular plate with notches machined on both sides. The depth of the notches shall be at least equal to one half of the test specimen thickness, and the distance between the notches shall be determined considering the requirements to produce shear failure in the gauge section. Furthermore, because the measured interlaminar shear strength may be dependent on the notch separation, it is recommended to conduct tests with different values of notch separation to determine this dependence. The edges of the test specimens shall be smooth, but not rounded or beveled. Table 1 contains recommended values for the dimensions associated with the test specimen shown in Fig. 2.

9.1.2 *The Iosipescu Test Specimen*—The required test specimen shape and tolerances are shown in Fig. 5, while Table 2 contains recommended values for the test specimen dimensions. If required, the specimen dimensions, particularly the notch angle, notch depth, and notch radius, may be adjusted to meet special material requirements, but any deviation from the recommended values contained in Table 2 shall be reported with the test results, although the standard tolerances shown in Fig. 5 still apply. The shear strength in any one of the principal shear planes of laminated CFCCs, CFCCs may be obtained by orienting the testing plane of the test specimen with the desired composite material plane as indicated in Fig. 6 for example. End-tabs, adhesively bonded to both faces of the test specimen away from the test section, are recommended to avoid local crushing failure and test specimen twisting in the fixture.

9.1.2.1 Due to limitations in material processing, in some instances it may be difficult to produce thick sections to conform with the dimensions and geometry shown in Table 2 and contained in Fig. 5 respectively, respectively; the test specimen geometry may be modified in order to obtain appropriate results. This may be true if the interlaminar shear strength is sought by using the Iosipescu test for example. In this case, adhesively bonded end-tabs may be used, and the depth and angle of the notches must be selected to promote shear failure between the V-notches. Fig. 7 shows an example of this situation.

<sup>6</sup> Available from several commercial test fixture suppliers or testing equipment companies.