



Designation: E2302 – 03a (Reapproved 2022)

Standard Test Method for Measurement of the Luminance Coefficient Under Diffuse Illumination of Pavement Marking Materials Using a Portable Reflectometer¹

This standard is issued under the fixed designation E2302; the number immediately following the designation indicates the year of original adoption or, in the case of revision, the year of last revision. A number in parentheses indicates the year of last reapproval. A superscript epsilon (ϵ) indicates an editorial change since the last revision or reapproval.

1. Scope

1.1 This test method covers measurement of the luminance coefficient under diffuse illumination of horizontal pavement markings, such as traffic stripes and surface symbols, and pavement surfaces, in a particular viewing direction using a portable reflectometer.

NOTE 1—The luminance coefficient under diffuse illumination is a measure of the reflection of horizontal pavement markings and pavement surfaces in a particular viewing direction in daylight or under road lighting. Diffuse illumination approximates daylight illumination from the overcast sky, and road lighting as an average of locations on the pavement surface.

1.2 The co-viewing angle of the reflectometer affects the readings. As specified by the European Committee for Standardization (CEN), the co-viewing angle shall be 2.29° .

1.3 This test method is intended to be used for field measurement of pavement markings and pavement surfaces but may be used to measure the performance of materials on sample panels before placing the marking material in the field.

1.4 *This standard does not purport to address all of the safety concerns, if any, associated with its use. It is the responsibility of the user of this standard to establish appropriate safety, health, and environmental practices and determine the applicability of regulatory limitations prior to use.*

1.5 *This international standard was developed in accordance with internationally recognized principles on standardization established in the Decision on Principles for the Development of International Standards, Guides and Recommendations issued by the World Trade Organization Technical Barriers to Trade (TBT) Committee.*

¹ This test method is under the jurisdiction of ASTM Committee E12 on Color and Appearance and is the direct responsibility of Subcommittee E12.10 on Retroreflection.

Current edition approved Feb. 1, 2022. Published February 2022. Originally approved in 2003. Last previous edition approved in 2016 as E2302 – 03a (2016). DOI: 10.1520/E2302-03AR22.

2. Referenced Documents

2.1 *ASTM Standards:*²

E284 *Terminology of Appearance*

E809 *Practice for Measuring Photometric Characteristics of Retroreflectors*

2.2 *Other Standard:*

CEN EN 1436 *Road Marking Materials—Road Marking Performance for Road Users*³

3. Terminology

3.1 The terminology used in this test method generally agrees with that used in Terminology E284.

3.2 *Definitions:*

3.2.1 *luminance coefficient under diffuse illumination; Q_d, n*—the ratio of luminance, L, in a particular viewing direction, of a projected surface to the illuminance of diffuse illumination, E, at the surface on the plane of the surface, expressed in candelas per square metre per lux ($\text{cd}\cdot\text{m}^{-2}\cdot\text{lx}^{-1}$).

3.2.1.1 *Discussion*—Q_d has a range from zero up to a maximum of $1/\pi =$ approximately $0.318 \text{ cd}\cdot\text{m}^{-2}\cdot\text{lx}^{-1}$. For convenience, the units used commonly are millicandelas per square metre per lux ($\text{mcd}\cdot\text{m}^{-2}\cdot\text{lx}^{-1}$) providing a range from zero up to $1000/\pi =$ approximately $318 \text{ mcd}\cdot\text{m}^{-2}\cdot\text{lx}^{-1}$.

3.2.2 *co-viewing angle, a, n*—the angle between the plane of the pavement marking surface and the observation axis.

3.2.3 *portable reflectometer, n*—a hand-held instrument that can be used in the field or laboratory for measurement of luminance coefficient under diffuse illumination.

² For referenced ASTM standards, visit the ASTM website, www.astm.org, or contact ASTM Customer Service at service@astm.org. For *Annual Book of ASTM Standards* volume information, refer to the standard's Document Summary page on the ASTM website.

³ Available from European Committee for Standardization (CEN), Avenue Marnix 17, B-1000, Brussels, Belgium, <http://www.cen.eu>.

3.2.4 *instrument standard, n*—working standard used to standardize the portable reflectometer.

4. Summary of Test Method

4.1 This test method involves the use of commercial portable reflectometers for determining the luminance coefficient under diffuse illumination in a particular viewing direction of horizontal coatings materials used in pavement markings.

4.2 The co-viewing angle is fixed at 2.29°.

4.3 The reflectometers use an external panel or other instrument standard of known luminance coefficient under diffuse illumination, Q_d.

4.4 The portable reflectometer is placed directly over the pavement marking to be measured, ensuring that the measurement area of the reflectometer fits within the width of the stripe, and the reading displayed by the reflectometer is recorded.

4.5 Readings shall be taken for the direction of traffic. Readings shall be taken for each direction of traffic separately for centerlines.

5. Significance and Use

5.1 The quality of the stripe for visibility in daylight or under road lighting is determined by the luminance coefficient under diffuse illumination, Q_d, and depends on the materials used, age, and wear pattern. These conditions shall be observed and noted by the user.

5.2 Under the same conditions of illumination and viewing, higher levels of Q_d correspond to higher levels of lightness.

5.3 Reflectivity of pavement (road) markings degrade with traffic wear and require periodic measurement to ensure that sufficient line visibility is provided to drivers.

5.4 For a given viewing distance, measurements of Q_d made with a reflectometer having a geometry corresponding to that distance are a good indicator of the visual ranking of material measured.

5.5 specified by CEN, the measurement geometry of the instrument is based on a viewing distance of 30 m and an eye height of 1.2 m.

5.6 It shall be the responsibility of the user to employ an instrument having the specified co-viewing angle.

6. Apparatus

6.1 *Portable Reflectometer:*

6.1.1 The reflectometer shall be portable, with the capability to be placed on various horizontal pavement markings in different locations.

6.1.2 The reflectometer shall be constructed so that placement on the highway pavement markings will preclude any stray light entering the measurement area of the instrument and affecting the reading. This may be done by shielding against stray light, or by subtraction of the stray light reading, or both. Alternatively, the reflectometer shall produce a warning signal when stray light could affect the reading.

6.1.3 For the convenience of the user, a marking shall be placed on the instrument to permit it to be aligned with the

direction of traffic, or the instrument design shall itself indicate the measuring direction in an obvious manner.

6.2 *Illumination System Requirements:*

6.2.1 The illumination system shall provide diffuse illumination, which can be obtained by indirect illumination through a sample gate from a photometric sphere of interior white, matte finish.

6.2.2 The illumination system shall have compensation for the increase of illumination caused by interreflection between a sample surface and the interior surfaces of the illumination system, for instance by means of a reading of the illuminance at a location close to the sample gate.

6.2.3 The diffuse illumination may be approximated by reflection from the interior surface of sphere or other shape or by other means. Enough testing shall be carried out to verify that flux received on the sample is approximately homogeneous. For measurements from all positions in the sample gate and in all directions, using a collection cone of an included angle of 8 degrees the ratio of the smallest to the largest measurement shall be minimum 0.8. The test shall be carried out with the sample gate open, and shall be repeated with the sample gate closed by a reflecting surface of white, matte finish with suitable openings to allow for the measurements.

6.2.3.1 The case of illumination by a sphere with a bottom aperture is shown in Fig. 1. For this arrangement sample gate should not be larger than necessary in view of the illuminated area needed in accordance with 6.4 and should stop at a distance before the sphere surface opposing the observation direction. In order that reflection in the sample surface shall not distort the uniformity of luminance of the interior sphere surface, the remaining part of the sphere, after introducing the bottom aperture, shall be minimum 0.8×D, where D is the diameter of the sphere. In this case, the test of 6.2.3 needs only to be applied with the sample gate open.

6.2.4 The sphere may be approximated by other shapes, but enough testing shall be carried out to verify that interior surfaces have approximately constant luminance. The ratio of the smallest to the largest luminance of interior surfaces shall be minimum 0.8, when measured in different directions through different locations at the sample gate. The test shall be carried out with the sample gate open, and shall be repeated with the sample gate closed by a reflecting surface of white, matte finish with suitable openings to allow for the measurements.

6.3 *Receiver Requirements:*

6.3.1 The receiver shall have sufficient sensitivity and range to accommodate luminance coefficient in diffuse illumination expected in use, typically from 1 to close to the maximum of approximately 318 mcd·m⁻²·lx⁻¹.

6.3.2 The combined spectral distribution of the illumination and the spectral responsivity of the receiver shall match the combined spectral distribution of CIE Illuminant D65 and the V(λ) spectral luminosity function according to the following criterion: For any relevant choice of plano parallel colored absorptive filter mounted in the path of light to the detector, when measuring a white reflective sample or calibration standard, the ratio of the Q_d measured with the filter to the Q_d measured without the filter shall be within 10 % of the

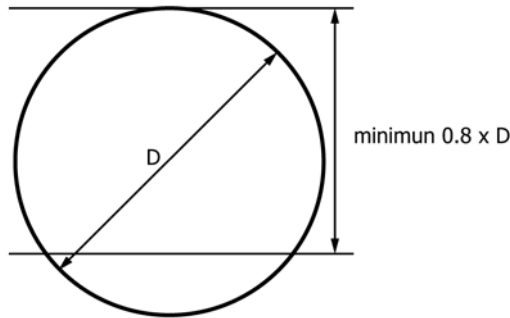

FIG. 1a Part of a sphere

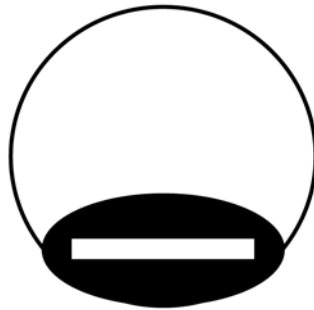

FIG. 1b Bottom aperture closed by a bottom surface with a sample gate

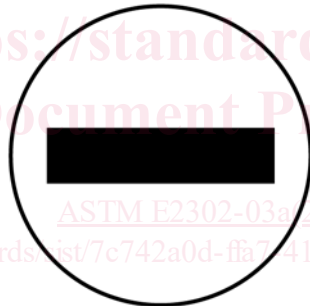

FIG. 1c Bottom surface with a sample gate

FIG. 1 Illumination System for a Portable Reflectometer: a) Part of a Sphere; b) Bottom Aperture Closed by a Bottom Surface with a Sample Gate; c) Bottom Surface with Sample Gate

Illuminant D65 luminous transmittance of the filter. See Fig. 2 for the position of the absorptive filter. Relevant absorptive filters shall include at least a yellow filter of color at about the acceptable limit toward green and a yellow filter of color at about the acceptable limit toward red.

NOTE 2—Absorptive long pass filters with pass wavelengths at about 515 nm and 550 nm are commercially available and correspond to greenish yellow and reddish yellow. Illuminant D65 luminous transmittance values must be derived by measurement of the individual filters, but typical values are given below.

Filter Type and Thickness	1 mm	2 mm	3 mm
515 nm	0.803	0.777	0.758
550 nm	n/a	n/a	0.489

6.3.2.1 If the instrument is intended to be used for materials of other colors, relevant absorptive filters shall include filters of such colors. It is recommended to test also the response to infrared radiation by means of an infrared absorptive filter, and to request that the Qd measured with the filter is small.

NOTE 3—Some combinations of light sources and detectors tend to give response to infrared radiation. An absorptive long pass filter with pass wavelength at about 715 nm is suitable. The Qd measured with the filter inserted should theoretically be zero, but a value from -3 to $3 \text{ mcd}\cdot\text{m}^{-2}\cdot\text{lx}^{-1}$ is acceptable.

6.3.3 The receiver may be either at optical infinity or at a finite distance from the measurement area, and the co-viewing angle shall be $2.29 \pm 0.05^\circ$ as determined from the center of the measurement area. See Fig. 3 for a diagram of the optics geometry. The co-viewing angle can be tested with light through the aperture stop at the detector, using a frame with pinholes and targets as shown in Fig. 4. For a non-collimated instrument, the pinholes shall be at a location corresponding to the center of the measurement field.

NOTE 4—To send light through the aperture stop at the detector involves opening of the reflectometer, which should be done according to instructions by the manufacturer of the reflectometer.

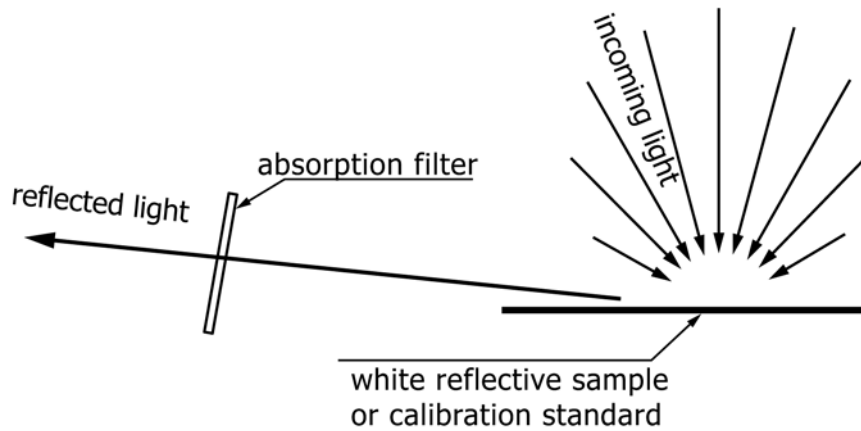

FIG. 2 Use of Absorptive Filter and White Reflective Sample or Calibration Standard to Test the Spectral Responsivity of the Receiver

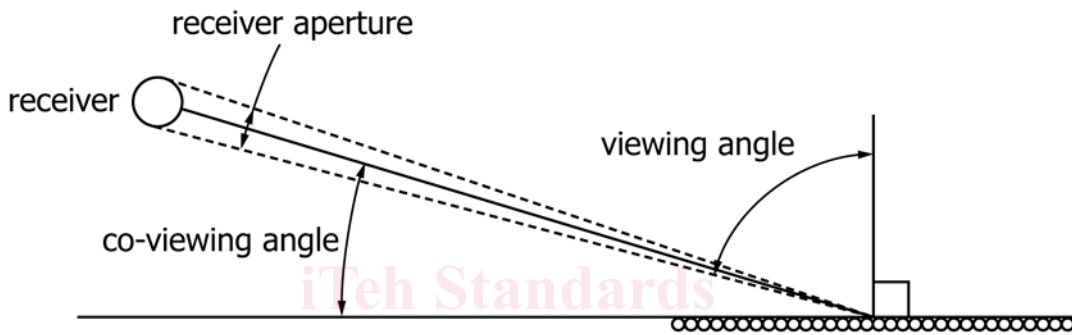

FIG. 3a Angle and aperture for non-collimating portable reflectometer is determined from the center of the sample measurement area.

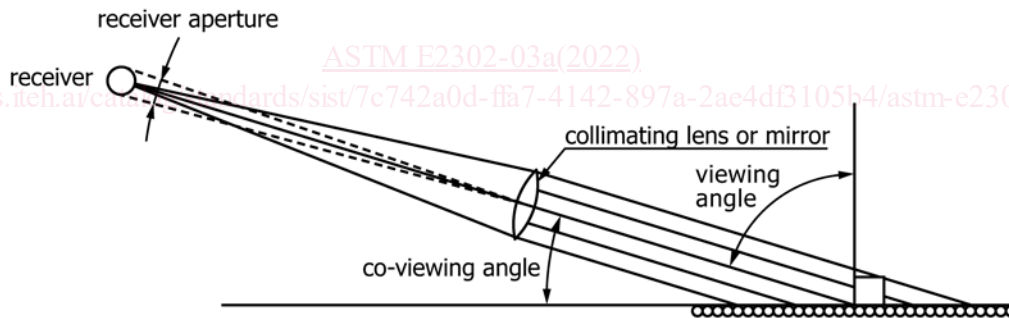

FIG. 3b Angle and aperture for collimating portable reflectometer is equal for all points of the sample measurement area.

FIG. 3 Optics Geometry Diagram for Portable Reflectometer: a) Angle and Aperture for Non-Collimating Portable Reflectometer; b) Angle and Aperture for Collimating Portable Reflectometer

6.3.4 As determined from the center of the measurement area, the aperture of the receiver shall not be larger than a square subtending 20 min of arc (0.33°) in both horizontal and vertical directions. For a collimated instrument, the frame shown in Fig. 4 can also be used to test the aperture angle, when the targets indicate maximum dimensions.

NOTE 5—The maximum receiver aperture dimensions are in agreement with CEN EN 1436.

6.3.5 The combined stability of the output of the light source and the receiver shall be such that readings will not

change more than $\pm 1\%$ after 10 s when the reflectometer is in contact with the pavement marking and ready to measure.

6.3.6 The linearity of the reflectometer photometric scale over the range of readings expected shall be within 2%. Correction factors may be used to ensure a linear response. A method for determining linearity is found in Annex A2 of Practice E809.

6.3.7 The reflectometer shall have a zero-adjust control, or an auto-zero function.

6.4 Measurement Geometry:

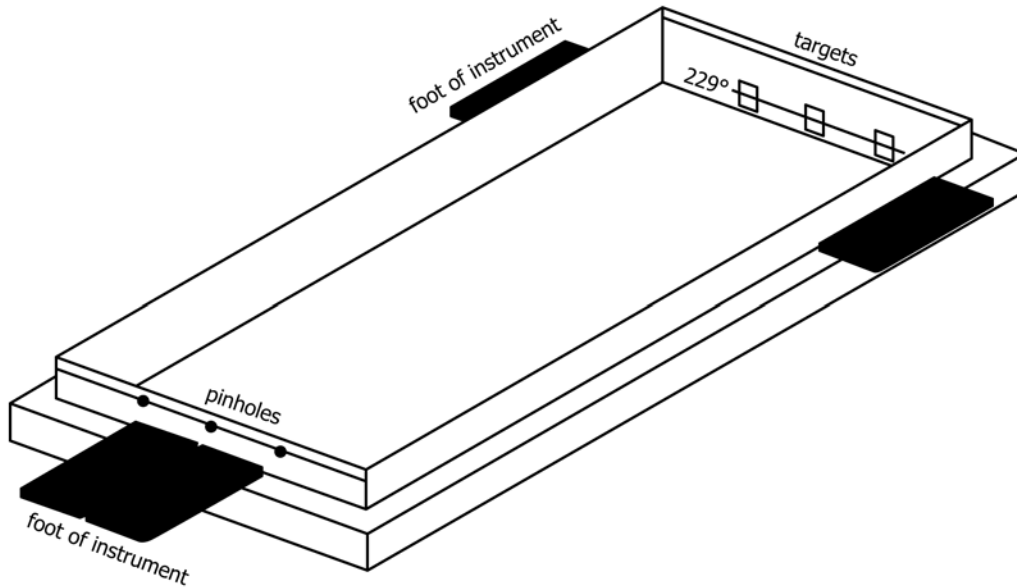

FIG. 4 Frame with Pinholes and Targets for Alternative Testing of the Co-viewing Angle and the Aperture for Only the Collimated Instruments

6.4.1 The detected area shall either be fully included within the illuminated area (called arrangement A) or the illuminated area shall be fully included within the detected area (called arrangement B).

NOTE 6—Arrangement A is advantageous to arrangement B in the sense that it leads to less variation of the measured Qd value with small tilts of the reflectometer that are unavoidable in practical field measurements.

6.4.2 The smaller of the two areas, detected or illuminated area, is the measurement area and shall be at least 50 cm². See Fig. 5 for a method of testing this area.

NOTE 7—The plate mentioned in Fig. 5 needs in most cases to be a glass plate with a diffuse upper surface, so that the area can be studied from the underside.

6.4.3 The larger of the two areas, illuminated or detected area, shall be large enough and have spatially uniform characteristics (either illumination or sensitivity) such that Qd values measured on a non-glossy reflective surface shall vary at most ±10 %, when the height position between surface and reflectometer H is changed from 0 mm to -1 mm, 1 mm or 2 mm. This may be performed in the dark. See Fig. 6 for a method of testing the variation.

NOTE 8—Shifts in height positions and tilts of a reflectometer are unavoidable in practical field measurements due to surface texture, particles on the surface, vertical curve of the pavement marking or profile. A reflectometer must have some reserve for practical conditions. Profiled pavement markings require even larger reserves, when profiles are higher than 2 mm, to be able to measure reliably the Qd values of such pavement markings.

7. Standardization

7.1 The reflectometer shall be standardized using an instrument standard consisting of a separate panel or other instrument standard with a known and reproducible luminance coefficient under diffuse illumination measured at the same geometry as used in the portable reflectometer. The instrument standard shall be standardized with diffuse illumination from an indirectly illuminated photometric sphere of sufficient dimensions, with the datum mark indicated on the standard. The instrument standard shall have a standardization value of the luminance coefficient under diffuse illumination, Qd, within the range of expected pavement markings. The standardization values shall be maintained by checking against other standards, or by standardization sufficiently often to ensure that no large uncertainties can occur. See Fig. 7 for a method of providing diffuse illumination on panels.

7.2 Subsequent to this standardization, an internal or secondary reference surface or standard may be used to maintain the standardization of the instrument during brief periods of transport to the test site area.

7.3 Note that transporting the instrument from an air conditioned area to the test site may result in fogging of mirrors or glass surfaces (if any) in the instrument. If there is any doubt concerning the calibration or the readings are not constant, allow the instrument to reach ambient conditions and recalibrate with the instrument standard.