



Designation: ~~E1876–15~~ E1876 – 21

Standard Test Method for Dynamic Young's Modulus, Shear Modulus, and Poisson's Ratio by Impulse Excitation of Vibration¹

This standard is issued under the fixed designation E1876; the number immediately following the designation indicates the year of original adoption or, in the case of revision, the year of last revision. A number in parentheses indicates the year of last reappraisal. A superscript epsilon (ϵ) indicates an editorial change since the last revision or reappraisal.

1. ~~Scope~~ Scope*

1.1 This test method covers determination of the dynamic elastic properties of elastic materials at ambient temperatures. Specimens of these materials possess specific mechanical resonant frequencies that are determined by the elastic modulus, mass, and geometry of the test specimen. The dynamic elastic properties of a material can therefore be computed if the geometry, mass, and mechanical resonant frequencies of a suitable (rectangular or cylindrical geometry) test specimen of that material can be measured. Dynamic Young's modulus is determined using the resonant frequency in either the flexural or longitudinal mode of vibration. The dynamic shear modulus, or modulus of rigidity, is found using torsional resonant vibrations. Dynamic Young's modulus and dynamic shear modulus are used to compute Poisson's ratio.

1.2 Although not specifically described herein, this test method can also be performed at cryogenic and high temperatures with suitable equipment modifications and appropriate modifications to the calculations to compensate for thermal expansion.

1.3 There are material specific ASTM standards that cover the determination of resonance frequencies and elastic properties of specific materials by sonic resonance or by impulse excitation of vibration. Test Methods [C215](#), [C623](#), [C747](#), [C848](#), [C1198](#), and [C1259](#) may differ from this test method in several areas (for example; sample size, dimensional tolerances, sample preparation). The testing of these materials shall be done in compliance with these material specific standards. Where possible, the procedures, sample specifications and calculations are consistent with these test methods.

1.4 The values stated in SI units are to be regarded as standard. No other units of measurement are included in this standard.

1.5 *This standard does not purport to address all of the safety concerns, if any, associated with its use. It is the responsibility of the user of this standard to establish appropriate ~~safety~~ safety, health, and health environmental practices and determine the applicability of regulatory limitations prior to use.*

1.6 *This international standard was developed in accordance with internationally recognized principles on standardization established in the Decision on Principles for the Development of International Standards, Guides and Recommendations issued by the World Trade Organization Technical Barriers to Trade (TBT) Committee.*

2. Referenced Documents

2.1 *ASTM Standards:*²

[C215](#) Test Method for Fundamental Transverse, Longitudinal, and Torsional Resonant Frequencies of Concrete Specimens

¹ This test method is under the jurisdiction of ASTM Committee [E28](#) on Mechanical Testing and is the direct responsibility of Subcommittee [E28.04](#) on Uniaxial Testing. Current edition approved ~~Dec. 15, 2015~~ Nov. 1, 2021. Published ~~March 2016~~ February 2022. Originally approved in 1997. Last previous edition approved in ~~2009~~ 2015 as ~~E1876–09~~ E1876 – 15. DOI: ~~10.1520/E1876-15~~ 10.1520/E1876-21.

² For referenced ASTM standards, visit the ASTM website, www.astm.org, or contact ASTM Customer Service at service@astm.org. For *Annual Book of ASTM Standards* volume information, refer to the standard's Document Summary page on the ASTM website.

*A Summary of Changes section appears at the end of this standard

- [C372 Test Method for Linear Thermal Expansion of Porcelain Enamel and Glaze Frits and Fired Ceramic Whiteware Products by Dilatometer Method](#)
- [C623 Test Method for Young’s Modulus, Shear Modulus, and Poisson’s Ratio for Glass and Glass-Ceramics by Resonance](#)
- [C747 Test Method for Moduli of Elasticity and Fundamental Frequencies of Carbon and Graphite Materials by Sonic Resonance](#)
- [C848 Test Method for Young’s Modulus, Shear Modulus, and Poisson’s Ratio For Ceramic Whitewares by Resonance](#)
- [C1161 Test Method for Flexural Strength of Advanced Ceramics at Ambient Temperature](#)
- [C1198 Test Method for Dynamic Young’s Modulus, Shear Modulus, and Poisson’s Ratio for Advanced Ceramics by Sonic Resonance](#)
- [C1259 Test Method for Dynamic Young’s Modulus, Shear Modulus, and Poisson’s Ratio for Advanced Ceramics by Impulse Excitation of Vibration](#)
- [E6 Terminology Relating to Methods of Mechanical Testing](#)
- [E177 Practice for Use of the Terms Precision and Bias in ASTM Test Methods](#)

3. Terminology

3.1 Definitions:

3.1.1 The definitions of terms relating to mechanical testing appearing in Terminology [E6](#) and [C1198](#) should be considered as applying to the terms used in this test method.

3.1.2 *dynamic elastic modulus, n*—the elastic modulus, either Young’s modulus or shear modulus, that is measured in a dynamic mechanical measurement.

3.1.3 *dynamic mechanical measurement, n*—a technique in which either the modulus or damping, or both, of a substance under oscillatory applied force or displacement is measured as a function of temperature, frequency, or time, or combination thereof.

3.1.4 *elastic limit* [FL⁻²], *n*—the greatest stress that a material is capable of sustaining without permanent strain remaining upon complete release of the stress. [E6](#)

3.1.5 *modulus of elasticity* [FL⁻²], *n*—the ratio of stress to corresponding strain below the proportional limit.

3.1.5.1 Discussion—

The stress-strain relationships of many materials do not conform to Hooke’s law throughout the elastic range, but deviate therefrom even at stresses well below the elastic limit. For such materials, the slope of either the tangent to the stress-strain curve at the origin or at a low stress, the secant drawn from the origin to any specified point on the stress-strain curve, or the chord connecting any two specified points on the stress-strain curve is usually taken to be the “modulus of elasticity.” In these cases, the modulus should be designated as the “tangent modulus,” the “secant modulus,” or the “chord modulus,” and the point or points on the stress-strain curve described. Thus, for materials where the stress-strain relationship is curvilinear rather than linear, one of the four following terms may be used:

- (a) *initial tangent modulus* [FL⁻²], *n*—the slope of the stress-strain curve at the origin.
- (b) *tangent modulus* [FL⁻²], *n*—the slope of the stress-strain curve at any specified stress or strain.
- (c) *secant modulus* [FL⁻²], *n*—the slope of the secant drawn from the origin to any specified point on the stress-strain curve.
- (d) *chord modulus* [FL⁻²], *n*—the slope of the chord drawn between any two specified points on the stress-strain curve below the elastic limit of the material.

3.1.5.2 Discussion—

Modulus of elasticity, like stress, is expressed in force per unit of area (pounds per square inch, etc.).

3.1.6 *Poisson’s ratio, μ, n*—the negative of the ratio of transverse strain to the corresponding axial strain resulting from an axial stress below the proportional limit of the material.

3.1.6.1 Discussion—

Poisson’s ratio may be negative for some materials, for example, a tensile transverse strain will result from a tensile axial strain.

3.1.6.2 Discussion—

Poisson’s ratio will have more than one value if the material is not isotropic. [E6](#)

3.1.7 *proportional limit* [FL⁻²], *n*—the greatest stress that a material is capable of sustaining without deviation from proportionality of stress to strain (Hooke’s law). [E6](#)

3.1.7.1 Discussion—

Many experiments have shown that values observed for the proportional limit vary greatly with the sensitivity and accuracy of the

testing equipment, eccentricity of loading, the scale to which the stress-strain diagram is plotted, and other factors. When determination of proportional limit is required, the procedure and the sensitivity of the test equipment should be specified.

3.1.8 *shear modulus, G* [FL⁻²], *n*—the ratio of shear stress to corresponding shear strain below the proportional limit, also called *torsional modulus* and *modulus of rigidity*.

3.1.8.1 *Discussion*—

The value of the shear modulus may depend on the direction in which it is measured if the material is not isotropic. Wood, many plastics and certain metals are markedly anisotropic. Deviations from isotropy should be suspected if the shear modulus differs from that determined by substituting independently measured values of Young's modulus, *E*, and Poisson's ratio, μ , in the relation:

$$G = \frac{E}{2(1+\mu)}$$

3.1.8.2 *Discussion*—

In general, it is advisable in reporting values of shear modulus to state the range of stress over which it is measured. **E6**

3.1.9 *Young's modulus, E* [FL⁻²], *n*—the ratio of tensile or compressive stress to corresponding strain below the proportional limit of the material. **E6**

3.2 *Definitions of Terms Specific to This Standard:*

3.2.1 *anti-nodes, n*—two or more locations in an unconstrained slender rod or bar in resonance that have local maximum displacements.

3.2.1.1 *Discussion*—

For the fundamental flexure resonance, the anti-nodes are located at the two ends and the center of the specimen.

3.2.2 *elastic, adj*—the property of a material such that an application of stress within the elastic limit of that material making up the body being stressed will cause an instantaneous and uniform deformation, which will be eliminated upon removal of the stress, with the body returning instantly to its original size and shape without energy loss. Most elastic materials conform to this definition well enough to make this resonance test valid.

3.2.3 *flexural vibrations, n*—the vibrations that occur when the oscillations in a slender rod or bar are in a plane normal to the length dimension.

<https://standards.iteh.ai/catalog/standards/sist/d0309392-86df-49c3-a8a4-dab52e4d5978/astm-e1876-21>

3.2.4 *homogeneous, adj*—the condition of a specimen such that the composition and density are uniform, so that any smaller specimen taken from the original is representative of the whole.

3.2.4.1 *Discussion*—

Practically, as long as the geometrical dimensions of the test specimen are large with respect to the size of individual grains, crystals, components, pores, or microcracks, the body can be considered homogeneous.

3.2.5 *in-plane flexure, n*—for rectangular parallelepiped geometries, a flexure mode in which the direction of displacement is in the major plane of the test specimen.

3.2.6 *isotropic, adj*—the condition of a specimen such that the values of the elastic properties are the same in all directions in the material.

3.2.6.1 *Discussion*—

Materials are considered isotropic on a macroscopic scale, if they are homogeneous and there is a random distribution and orientation of phases, crystallites, components, pores, or microcracks.

3.2.7 *longitudinal vibrations, n*—the vibrations that occur when the oscillations in a slender rod or bar are parallel to the length of the rod or bar.

3.2.8 *nodes, n*—one or more locations of a slender rod or bar in resonance that have a constant zero displacement.

3.2.8.1 *Discussion*—

For the fundamental flexural resonance, the nodes are located at 0.224 *L* from each end, where *L* is the length of the specimen.

3.2.9 *out-of-plane flexure, n*—for rectangular parallelepiped geometries, a flexure mode in which the direction of displacement is perpendicular to the major plane of the test specimen.

3.2.10 *resonant frequency, n*—naturally occurring frequencies of a body driven into flexural, torsional, or longitudinal vibration that are determined by the elastic modulus, mass, and dimensions of the body.

3.2.10.1 *Discussion*—

The lowest resonant frequency in a given vibrational mode is the fundamental resonant frequency of that mode.

3.2.11 *slender rod or bar, n*—in dynamic elastic property testing, a specimen whose ratio of length to minimum cross-sectional dimension is at least five and preferably in the range from 20 to 25.

3.2.12 *torsional vibrations, n*—the vibrations that occur when the oscillations in each cross-sectional plane of a slender rod or bar are such that the plane twists around the length dimension axis.

3.3 *Symbols:*

- A = plate constant; used in Eq A1.1
- D = diameter of rod or diameter of disk
- D_e = effective diameter of the bar; defined in Eq 10 and Eq 11
- E = dynamic Young's modulus; defined in Eq 1 and Eq 4, and Eq A1.4
- E_1 = first natural calculation of the dynamic Young's modulus, used in Eq A1.2
- E_2 = second natural calculation of the dynamic Young's modulus, used in Eq A1.3
- G = dynamic shear modulus, defined in Eq 12, Eq 14, and Eq A1.5
- K = correction factor for the fundamental longitudinal mode to account for the finite diameter-to-length ratio and Poisson's Ratio, defined in Eq 8
- K_i = geometric factor for the resonant frequency of order i , see Table A1.2 and Table A1.3
- L = specimen length
- M_T = dynamic elastic modulus at temperature T (either the dynamic Young's modulus E , or the dynamic shear modulus G)
- M_0 = dynamic elastic modulus at room temperature (either the dynamic Young's modulus E or the dynamic shear modulus G)
- M_0 = dynamic elastic modulus at room temperature (either the dynamic Young's modulus E or the dynamic shear modulus G)
- R = correction factor for the geometry of the bar, defined in Eq 13
- T_1 = correction factor for fundamental flexural mode to account for finite thickness of bar and Poisson's ratio; defined in Eq 2
- T_1' = correction factor for fundamental flexural mode to account for finite diameter of rod, Poisson's ratio; defined in Eq 4 and Eq 6
- T_1'' = correction factor for fundamental flexural mode to account for finite diameter of rod, Poisson's ratio; defined in Eq 5.
- b = specimen width
- f = frequency
- f_0 = resonant frequency at room temperature in furnace or cryogenic chamber
- f_1 = first natural resonant frequency; used in Eq A1.2
- f_2 = second natural frequency; used in Eq A1.3
- f_f = fundamental resonant frequency of bar in flexure; used in Eq 1
- f_l = fundamental longitudinal resonant frequency of a slender bar; used in Eq 7 and Eq 9
- f_T = resonant frequency measured in the furnace or cryogenic chamber at temperature T , used in Eq 16
- f_t = fundamental resonant frequency of bar in torsion; used in Eq 12 and Eq 14
- m = specimen mass
- n = the order of the resonance ($n=1,2,3,\dots$)
- r = radius of the disk, used in Eq A1.1
- t = specimen, disk or bar, thickness
- T_1 = correction factor for fundamental flexural mode to account for finite thickness of the bar and Poisson's ratio; defined in Eq 2
- T_1'' = correction factor for fundamental flexural mode to account for finite thickness of the rod and Poisson's ratio; defined in Eq 4
- ΔT = temperature difference between the test temperature T and room temperature, used in Eq 16
- ΔT_1 = temperature difference between the test temperature T and room temperature Eq 16
- α = average linear thermal expansion coefficient (mm/mm/°C) from room temperature to test temperature; used in Eq 16

μ = Poisson's ratio

ρ = density of the disk; used in Eq A1.1

4. Summary of Test Method

4.1 This test method measures the fundamental resonant frequency of test specimens of suitable geometry by exciting them mechanically by a singular elastic strike with an impulse tool. A transducer (for example, contact accelerometer or non-contacting microphone) senses the resulting mechanical vibrations of the specimen and transforms them into electric signals. Specimen supports, impulse locations, and signal pick-up points are selected to induce and measure specific modes of the transient vibrations. The signals are analyzed, and the fundamental resonant frequency is isolated and measured by the signal analyzer, which provides a numerical reading that is (or is proportional to) either the frequency or the period of the specimen vibration. The appropriate fundamental resonant frequencies, dimensions, and mass of the specimen are used to calculate dynamic Young's modulus, dynamic shear modulus, and Poisson's ratio.

5. Significance and Use

5.1 This test method may be used for material development, characterization, design data generation, and quality control purposes.

5.2 This test method is specifically appropriate for determining the dynamic elastic modulus of materials that are elastic, homogeneous, and isotropic **(1)**.³

5.3 This test method addresses the room temperature determination of dynamic elastic moduli of elasticity of slender bars (rectangular cross section) rods (cylindrical), and flat disks. Flat plates may also be measured similarly, but the required equations for determining the moduli are not presented.

5.4 This dynamic test method has several advantages and differences from static loading techniques and from resonant techniques requiring continuous excitation.

5.4.1 The test method is nondestructive in nature and can be used for specimens prepared for other tests. The specimens are subjected to minute strains; hence, the moduli are measured at or near the origin of the stress-strain curve, with the minimum possibility of fracture.

5.4.2 The impulse excitation test uses an impact tool and simple supports for the test specimen. There is no requirement for complex support systems that require elaborate setup or alignment.

5.5 This technique can be used to measure resonant frequencies alone for the purposes of quality control and acceptance of test specimens of both regular and complex shapes. A range of acceptable resonant frequencies is determined for a specimen with a particular geometry and mass. The technique is particularly suitable for testing specimens with complex geometries (other than parallelepipeds, cylinders/rods, or disks) that would not be suitable for testing by other procedures. Any specimen with a frequency response falling outside the prescribed frequency range is rejected. The actual dynamic elastic modulus of each specimen need not be determined as long as the limits of the selected frequency range are known to include the resonant frequency that the specimen must possess if its geometry and mass are within specified tolerances.

5.6 If a thermal treatment or an environmental exposure affects the elastic response of the test specimen, this test method may be suitable for the determination of specific effects of thermal history, environment exposure, and so forth. Specimen descriptions should include any specific thermal treatments or environmental exposures that the specimens have received.

6. Interferences

6.1 The relationships between resonant frequency and dynamic elastic modulus presented herein are specifically applicable to homogeneous, elastic, isotropic materials.

6.1.1 This method of determining the moduli is applicable to composite and inhomogeneous materials only with careful consideration of the effect of inhomogeneities and anisotropy. The character (volume fraction, size, morphology, distribution,

³ The boldface numbers in parentheses refer to the list of references at the end of this standard.

orientation, elastic properties, and interfacial bonding) of the reinforcement and inhomogeneities in the specimens will have a direct effect on the elastic properties of the specimen as a whole. These effects must be considered in interpreting the test results for composites and inhomogeneous materials.

6.1.2 The procedure involves measuring transient elastic vibrations. Materials with very high damping capacity may be difficult to measure with this technique if the vibration damps out before the frequency counter can measure the signal (commonly within three to five cycles).

6.1.3 If specific surface treatments (coatings, machining, grinding, etching, and so forth) change the elastic properties of the near-surface material, there will be accentuated effects on the properties measured by this flexural method, as compared to static/bulk measurements by tensile or compression testing.

6.1.4 This test method is not satisfactory for specimens that have major discontinuities, such as large cracks (internal or surface) or voids.

6.2 This test method for determining moduli is limited to specimens with regular geometries (rectangular parallelepiped, cylinders, and disks) for which analytical equations are available to relate geometry, mass, and modulus to the resonant vibration frequencies. This test method is not appropriate for determining the elastic properties of materials that cannot be fabricated into such geometries.

6.2.1 The analytical equations assume parallel and concentric dimensions for the regular geometries of the specimen. Deviations from the specified tolerances for the dimensions of the specimens will change the resonant frequencies and introduce error into the calculations.

6.2.2 Edge treatments such as chamfers or radii are not considered in the analytical equations. Edge chamfers change the resonant frequency of the test bars and introduce error into the calculations of the dynamic elastic modulus. It is recommended that specimens for this test method not have chamfered or rounded edges.

6.2.3 For specimens with as-fabricated and rough or uneven surfaces, variations in dimension can have a significant effect in the calculations. For example, in the calculation of dynamic elastic modulus, the modulus value is inversely proportional to the cube of the thickness. Uniform specimen dimensions and precise measurements are essential for accurate results.

6.3 This test method assumes that the specimen is vibrating freely, with no significant restraint or impediment. Specimen supports should be designed and located properly in accordance with the instructions so the specimen can vibrate freely in the desired mode. In using direct contact transducers, the transducer should be positioned away from anti-nodes and with minimal force to avoid interference with free vibration.

6.4 Proper location to the impulse point and transducer is important in introducing and measuring the desired vibration mode. The locations of the impulse point and transducer should not be changed in multiple readings; changes in position may develop and detect alternate vibration modes. In the same manner, the force used in impacting should be consistent in multiple readings.

6.5 If the frequency readings are not repeatable for a specific set of impulse and transducer locations on a specimen, it may be because several different modes of vibration are being developed and detected in the test. The geometry of the test bar and desired vibration mode should be evaluated and used to identify the nodes and anti-nodes of the desired vibrations. More consistent measurements may be obtained if the impulse point and transducer locations are shifted to induce and measure the single desired mode of vibration.

7. Apparatus

7.1 Apparatus suitable for accurately detecting, analyzing, and measuring the fundamental resonant frequency or period of a vibrating free-free beam is used. The test apparatus is shown in Fig. 1. It consists of an impulser, a suitable pickup transducer to convert the mechanical vibration into an electrical signal, an electronic system (consisting of a signal conditioner/amplifier, a signal analyzer, and a frequency readout device), and a support system. Commercial instrumentation is available that measures the frequency or period of the vibrating specimen.

7.2 *Impulser*—The exciting impulse is imparted by lightly striking the specimen with a suitable implement. This implement should have most of its mass concentrated at the point of impact and have mass sufficient to induce a measurable mechanical vibration,

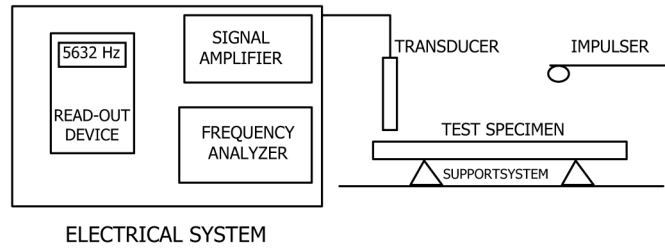

FIG. 1 Block Diagram of Typical Test Apparatus

but not so large as to displace or damage the specimen physically. In practice, the size and geometry of the impulser depends on the size and weight of the specimen and the force needed to produce vibration. For commonly tested geometries (small bars, rods, and disks) an example of such an impulser is a steel sphere 0.5 cm in diameter glued to the end of a flexible 10-cm long polymer rod. (See Fig. 2.) An alternate impulser is a solid metal, ceramic, or polymer sphere (0.1 to 1.0 cm in diameter) dropped on the specimen through a guide tube to ensure proper impulse position.

7.3 *Signal Pickup*—Signal detection may be by means of transducers in direct contact with the specimen or by noncontact transducers. Contact transducers are commonly accelerometers using piezoelectric or strain gage methods to measure the vibration. Non contact transducers are commonly acoustic microphones, but they may also use laser, magnetic, or capacitance methods to measure the vibration. The frequency range of the transducer shall be sufficient to measure the expected frequencies of the specimens of interest. A suitable range would be from 100 Hz to 50 kHz for most advanced ceramic test specimens. (Smaller and stiffer specimens vibrate at higher frequencies.) The frequency response of the transducer across the frequency range of interest shall have a bandwidth of at least 10 % of the maximum measured frequency before -3 dB power loss occurs.

7.4 *Electronic System*—The electronic system consists of a signal conditioner/amplifier, signal analyzer, and a frequency readout device. The system should have accuracy and precision sufficient to measure the frequencies of interest to an accuracy of 0.1 %. The signal conditioner/amplifier should be suitable to power the transducer and provide an appropriate amplified signal to the signal analyzer. The signal analysis system consists of a frequency counting device and a readout device. Appropriate devices are frequency counter systems with storage capability or digital storage oscilloscopes with a frequency counter module. With the digital storage oscilloscope, a Fast Fourier Transform signal analysis system may be useful for analyzing more complex waveforms and identifying the fundamental resonant frequency.

7.5 *Support System*— The support shall isolate the specimen from extraneous vibration without restricting the desired mode of specimen vibration. Appropriate materials should be stable at the test temperatures. Support materials may be either soft or rigid for ambient conditions. An example of a soft material is a compliant elastomeric material, such as a polyurethane foam strip. Such foam strips should have simple flat surfaces for the specimen to rest on. Rigid materials, such as metal or ceramic, should have sharp knife edges or cylindrical surfaces on which the specimen should rest. The rigid supports should rest on isolation pads to prevent ambient vibrations from being picked up by the transducer. Wire suspension may also be used. Specimens shall be supported along node lines appropriate for the desired vibration in the locations described in Section 8.

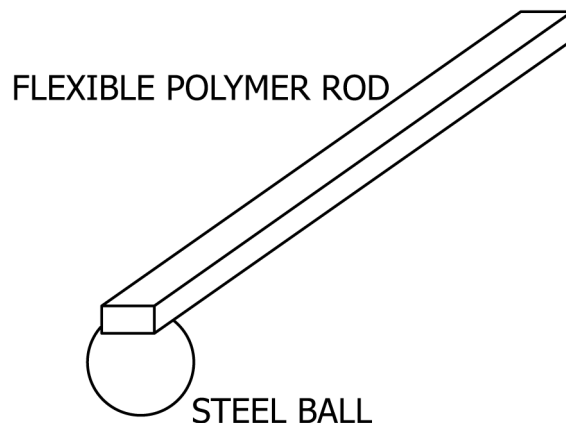

FIG. 2 Diagram of Typical Impulser for Small Specimens

8. Test Specimen

8.1 ~~The specimens shall be prepared~~ Prepare the specimens so that they are either rectangular or circular in cross section. Either geometry may be used to measure both dynamic Young's modulus and dynamic shear modulus. ~~Although the equations for computing shear modulus with a cylindrical specimen are both simpler and more accurate than those used with a rectangular bar, experimental difficulties in obtaining torsional resonant frequencies for a cylindrical specimen usually preclude its use for determining dynamic shear modulus.~~

NOTE 1—Although the equations for computing shear modulus with a cylindrical specimen are both simpler and more accurate than those used with a rectangular bar, experimental difficulties in obtaining torsional resonant frequencies for a cylindrical specimen usually preclude its use for determining dynamic shear modulus.

8.2 ~~Resonant frequencies for a given specimen are functions of the specimen dimensions as well as its mass and moduli; dimensions should therefore be selected with this relationship in mind. The selection of size shall be made~~ Select the size so that, for an estimated dynamic elastic modulus, the resonant frequencies measured will fall within the range of frequency response of the transducers and electronics used. For a slender ~~rod, test specimen,~~ the ratio of length to minimum cross-sectional dimension shall have a value of at least five (5). However, a ratio of approximately 20 ~~≈ 25 is preferred to 25~~ should be used for ease in calculation. For dynamic shear modulus measurements of rectangular ~~bars, test specimens,~~ a ratio of width to thickness ~~of should be five (5) or greater is recommended for minimizing to minimize~~ experimental difficulties.

NOTE 2—Resonant frequencies for a given specimen are functions of the specimen dimensions as well as its mass and moduli.

8.3 All surfaces on the rectangular specimen shall be flat. Opposite surfaces across the length, thickness, and width shall be parallel to within ~~0.1 %.~~ 0.1 %. The cylindrical specimen shall be round and constant in diameter to within ~~0.1 %.~~ 0.1 %.

8.4 ~~Specimen mass shall be determined~~ Measure the specimen mass to within ~~0.1 %.~~ 0.1 %.

8.5 ~~Specimen length shall be measured to within 0.1 %. The thickness and width of the rectangular specimen shall be measured to within 0.1 % at three locations and an average determined. The diameter of the cylindrical specimen shall be measured to within 0.1 % at three locations and an average determined.~~

8.5 **Table 1** illustrates how uncertainties in the measured parameters influence the calculated dynamic elastic modulus. It shows that calculations are most sensitive to error in the measurement of the thickness. Measure the specimen length to within 0.1 %. Measure the thickness and width of the rectangular specimen to within 0.1 % at three locations and determine an average. Measure the diameter of the cylindrical specimen to within 0.1 % at three locations and determine an average. Take special care when measuring the thickness of samples with a thickness of specimen dimensions that are less than 3 mm.

NOTE 3— The accuracy requirements of 8.4 and 8.5 set practical requirements for the minimum specimen dimensions. For example, the accuracy of a typical laboratory micrometer is $a_m = 0.003$ mm; meeting the requirement of 8.5 requires that the minimum width, thickness, or diameter of the test specimen be 3 mm. The accuracy of a typical precision laboratory balance is 0.001 g; meeting the requirement of 8.4 requires that the minimum mass of the test specimen be 1 g. Given these minimum dimensions and mass, meeting the requirements of 8.4 and 8.5 requires that the minimum length of a metal alloy test specimen with density of 0.008 g/mm^3 be 13.9 mm. A test specimen of a typical ceramic, with lower density, will be correspondingly longer

NOTE 4—Table 1 illustrates how uncertainties in the measured parameters influence the calculated dynamic elastic modulus. It shows that calculations are most sensitive to uncertainty in the measurement of the thickness, diameter, and length.

TABLE 1 Effects of Variable Error Uncertainty on Dynamic Elastic Modulus Calculation Uncertainty

Variable	Measurement Error Uncertainty	Variable Exponent in Dynamic Elastic Modulus Equation	Calculation Error Uncertainty
Frequency (f)	0.1 %	f^2	0.2 %
Length (L)	0.1 %	L^3	0.3 %
Mass (m)	0.1 %	m	0.1 %
Width (b)	0.1 %	b^{-1}	0.1 %
Thickness (t)	0.1 %	t^{-3}	0.3 %
Diameter (D)	0.1 %	D^{-4}	0.4 %

9. Procedure

9.1 Activate all electrical equipment, and allow it to stabilize according to the manufacturer’s recommendations.

9.2 Use a test specimen established as a verification/calibration standard to verify the equipment response and accuracy.

9.3 *Fundamental Flexural Resonant Frequency (Out-of-Plane Flexure):*

9.3.1 Place the specimen on the supports located at the fundamental nodal points (0.224 L from each end; see Fig. 3).

9.3.2 Determine the direction of maximum sensitivity for the transducer. Orient the transducer so that it will detect the desired vibration.

9.3.2.1 *Direct-Contact Transducers*—Place the transducer in contact with the test specimen to pick up the desired vibration. If the transducer is placed at an anti-node (location of maximum displacement), it may mass load the specimen and modify the natural vibration. The transducer should be placed only as far from the nodal points as necessary to obtain a reading (see Fig. 3). This location will minimize the damping effect from the contacting transducer. The transducer contact force should be consistent, with good response and minimal interference with the free vibration of the specimen.

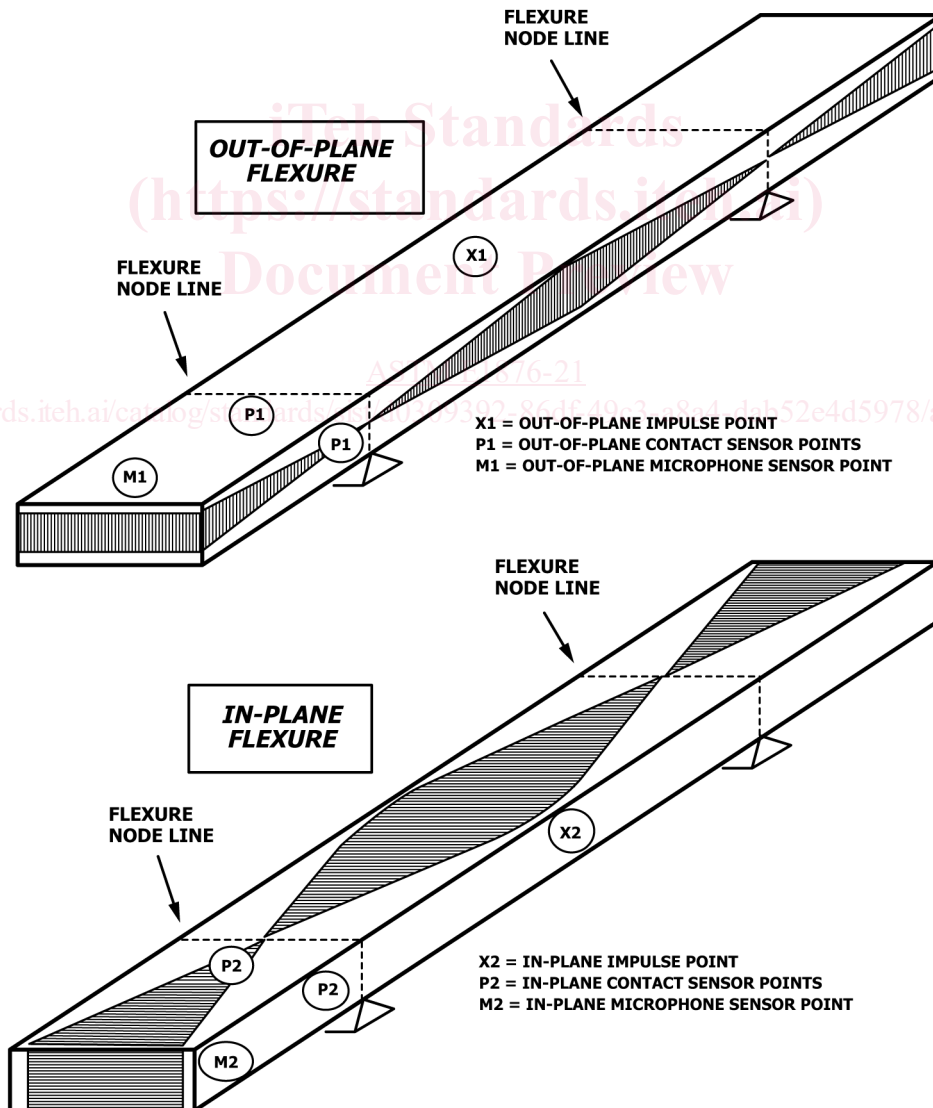

FIG. 3 Rectangular Specimens Tested for In-Plane and Out-of-Plane Flexure

9.3.2.2 *Non-Contact Transducers*—Place the non-contact transducer over an anti-node point and close enough to the test specimen to pick up the desired vibration, but not so close as to interfere with the free vibration (see Fig. 3).

9.3.3 Strike the specimen lightly and elastically, either at the center of the specimen or at the opposite end of the specimen from the detecting transducer (see Fig. 3).

9.3.4 Record the resultant reading, and repeat the test until five consecutive readings are obtained that lie within 1 % of each other. Use the average of these five readings to determine the fundamental resonant frequency in flexure.

9.4 *Fundamental Flexural Resonant Frequency (In-Plane Flexure):*

9.4.1 This procedure is the same as 9.3, except that the direction of vibration is in the major plane of the specimen. This measurement may be performed in two ways. In one case, move the transducer and impuser 90° around the long axis of the test specimen to introduce and detect vibrations in the major plane (see Fig. 3). In the alternate method, rotate the test bar 90° around its long axis and reposition it on the specimen supports. Transpose the width and thickness dimensions in the calculations. For homogeneous, isotropic materials, the calculated moduli should be the same as the moduli calculated from the out-of-plane frequency. The comparison of in-plane and out-of-plane frequency measurements can thus be used as a cross check of experimental methods and calculations.

9.5 *Fundamental Torsional Resonant Frequency:*

9.5.1 Support the specimen at the midpoint of its length and width (the torsional nodal planes) (see Fig. 4).

9.5.2 Locate the transducer at one quadrant of the specimen, preferably at approximately 0.224 L from one end and toward the edge. This location is a nodal point of flexural vibration and will minimize the possibility of detecting a spurious flexural mode (see Fig. 4).

9.5.3 Strike the specimen on the quadrant diagonally opposite the transducer, again at 0.224 L from the end and near the edge. Striking at a flexural nodal point will minimize the possibility of exciting a flexural mode of vibration (see Fig. 4).

9.5.4 Record the resultant reading, and repeat the test until five consecutive readings are obtained that lie within 1 % of each other. Use the average of these five readings to determine the fundamental resonant frequency in torsion.

<https://standards.iteh.ai/catalog/standards/sist/d0309392-86df-49c3-a8a4-dab52e4d5978/astm-e1876-21>

9.6 *Fundamental Longitudinal Resonant Frequency:*

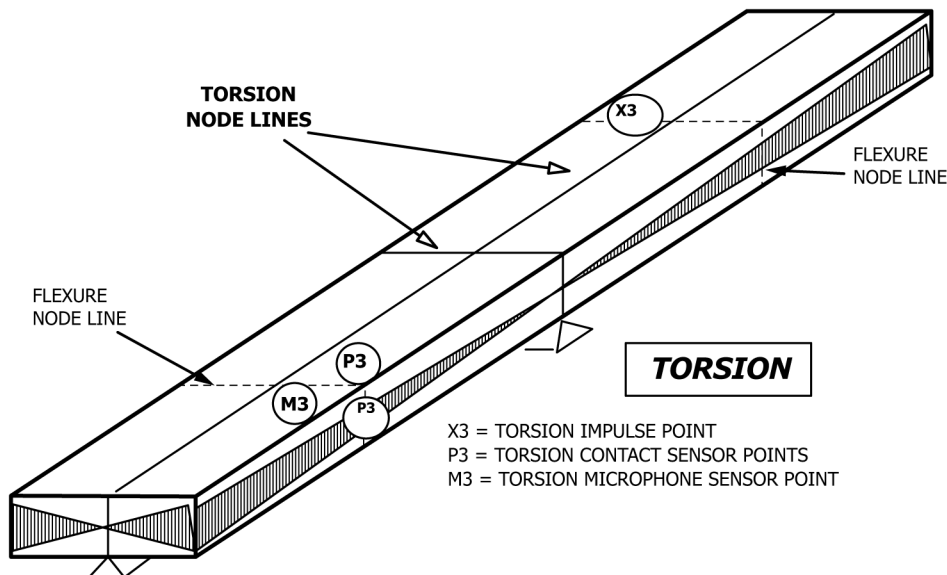

FIG. 4 Rectangular Specimen Tested for Torsional Vibration

9.6.1 Support the specimen at the midpoint of its length and width (the same as for torsion), or brace the specimen at its mid length, the fundamental longitudinal nodal position.

9.6.2 Locate the detecting transducer at the center of one of the end faces of the specimen.

9.6.3 Strike the end face of the specimen opposite to the face where the transducer is located.

9.6.4 Record the resultant reading, and repeat the test, until five consecutive readings are obtained that lie within 1 % of each other. Use the average of these five readings to determine the fundamental longitudinal resonant frequency.

10. Calculation

10.1 Dynamic Young's Modulus (1,2):

10.1.1 For the fundamental flexure resonant frequency of a rectangular bar (2),

$$E = 0.9465 \left(\frac{mf_f^2}{b} \right) \left(\frac{L^3}{t^3} \right) T_1 \quad (1)$$

where:

E = Dynamic Young's modulus, Pa,

m = mass of the bar, g (see Note 1);

\bar{m} = mass of the bar, g (see Note 5),

b = width of the bar, mm (see Note 1),

\bar{b} = width of the bar, mm (see Note 5),

L = length of the bar, mm (see Note 1),

\bar{L} = length of the bar, mm (see Note 5),

t = thickness of the bar, mm (see Note 1),

\bar{t} = thickness of the bar, mm (see Note 5),

f_f = fundamental resonant frequency of bar in flexure, Hz, and

T_1 = correction factor for fundamental flexural mode to account for finite thickness of bar, Poisson's ratio, and so forth.

$$T_1 = 1 + 6.585 (1 + 0.0752 \mu + 0.8109 \mu^2) \left(\frac{t}{L} \right)^2 - 0.868 \left(\frac{t}{L} \right)^4 \quad (2)$$

$$- \left[\frac{8.340 (1 + 0.2023 \mu + 2.173 \mu^2) \left(\frac{t}{L} \right)^4}{1.000 + 6.338 (1 + 0.1408 \mu + 1.536 \mu^2) \left(\frac{t}{L} \right)^2} \right]$$

where:

μ = Poisson's ratio.

NOTE 5—In the dynamic elastic modulus equations, the mass and length terms are given in units of grams and millimetres. However, the defined equations can also be used with mass and length terms in units of kilograms and metres with no changes in terms or exponents.

10.1.1.1 If $L/t \geq 20$, T_1 can be simplified to the following:

$$T_1 = \left[1.000 + 6.585 \left(\frac{t}{L} \right)^2 \right] \quad (3)$$

and E can be calculated directly.

10.1.1.2 If $L/t < 20$ and Poisson's ratio is known, then T_1 can be calculated directly from Eq 2 and then used to calculate E .

10.1.1.3 If $L/t < 20$ and Poisson's ratio is not known, assume an initial Poisson's ratio to begin the computations. Use an iterative process to determine a value of Poisson's ratio, based on experimental dynamic Young's modulus and dynamic shear modulus. The iterative process is flowcharted in Fig. 5 and described in (1) through (5),

(1) Determine the fundamental flexural and torsional resonant frequency of the rectangular test specimen, as described in Section 9. Using Eq 12, calculate the dynamic shear modulus of the test specimen for the fundamental torsional resonant frequency.