



Designation: C829 – 81 (Reapproved 2022)

Standard Practices for Measurement of Liquidus Temperature of Glass by the Gradient Furnace Method¹

This standard is issued under the fixed designation C829; the number immediately following the designation indicates the year of original adoption or, in the case of revision, the year of last revision. A number in parentheses indicates the year of last reapproval. A superscript epsilon (ϵ) indicates an editorial change since the last revision or reapproval.

1. Scope

1.1 These practices cover procedures for determining the liquidus temperature (**Note 1**) of a glass (**Note 1**) by establishing the boundary temperature for the first crystalline compound, when the glass specimen is held at a specified temperature gradient over its entire length for a period of time necessary to obtain thermal equilibrium between the crystalline and glassy phases.

NOTE 1—These terms are defined in Terminology C162.

1.2 Two methods are included, differing in the type of sample, apparatus, procedure for positioning the sample, and measurement of temperature gradient in the furnace. Both methods have comparable precision. Method B is preferred for very fluid glasses because it minimizes thermal and mechanical mixing effects.

1.2.1 *Method A* employs a trough-type platinum container (tray) in which finely screened glass particles are fused into a thin lath configuration defined by the trough.

1.2.2 *Method B* employs a perforated platinum tray on which larger screened particles are positioned one per hole on the plate and are therefore melted separately from each other.²

1.3 *This standard does not purport to address all of the safety concerns, if any, associated with its use. It is the responsibility of the user of this standard to establish appropriate safety, health, and environmental practices and determine the applicability of regulatory limitations prior to use.*

1.4 *This international standard was developed in accordance with internationally recognized principles on standardization established in the Decision on Principles for the Development of International Standards, Guides and Recommendations issued by the World Trade Organization Technical Barriers to Trade (TBT) Committee.*

¹ These practices are under the jurisdiction of ASTM Committee C14 on Glass and Glass Products and are the direct responsibility of Subcommittee C14.04 on Physical and Mechanical Properties.

Current edition approved Feb. 1, 2022. Published March 2022. Originally approved in 1976. Last previous edition approved in 2015 as C829 – 81 (2015). DOI: 10.1520/C0829-81R22.

² From *NBS Research Paper RP2096*, Vol 44, May 1950, by O. H. Grauer and E. H. Hamilton, with modification and improvement by K. J. Gajewski, Ford Motor Co., Glass Research and Development Office (work unpublished).

2. Referenced Documents

2.1 *ASTM Standards*:³

C162 *Terminology of Glass and Glass Products*

2.2 *Other Document*:

NIST Certificate for Liquidus Temperature, SRM 773⁴

3. Significance and Use

3.1 These practices are useful for determining the maximum temperature at which crystallization will form in a glass, and a minimum temperature at which a glass can be held, for extended periods of time, without crystal formation and growth.

4. Apparatus

4.1 The apparatus for determining the liquidus temperature shall consist essentially of an electrically heated gradient furnace, a device for controlling the furnace temperature, temperature measuring equipment, and other items listed.

4.1.1 *Furnace*:

4.1.1.1 *Method A*—Horizontal temperature gradient, electrically heated furnace, tube type, as illustrated in Figs. 1-3 and described in A1.1.

4.1.1.2 *Method B*—An alternative furnace detail employing pregrooved Al₂O₃ cores and dual windings, as illustrated in Figs. 4 and 5, and described in A1.2.

4.1.1.3 Equivalent temperature gradient conditions may also be obtained with furnaces having multiple windings equipped with separate power and control, or a tapped winding shunted with suitable resistances. *For high precision, temperature gradients in excess of 10 °C/cm should be avoided.*

4.1.2 *Furnace Temperature Control*:

4.1.2.1 *Method A*—A suitable temperature controller shall be provided to maintain a fixed axial temperature distribution over the length of the furnace.

4.1.2.2 *Method B*—A rheostat shall be used to supply power to the outer winding. A separate rheostat and controller shall be

³ For referenced ASTM standards, visit the ASTM website, www.astm.org, or contact ASTM Customer Service at service@astm.org. For *Annual Book of ASTM Standards* volume information, refer to the standard's Document Summary page on the ASTM website.

⁴ Available from National Institute of Standards and Technology (NIST), 100 Bureau Dr., Stop 1070, Gaithersburg, MD 20899-1070, http://www.nist.gov.

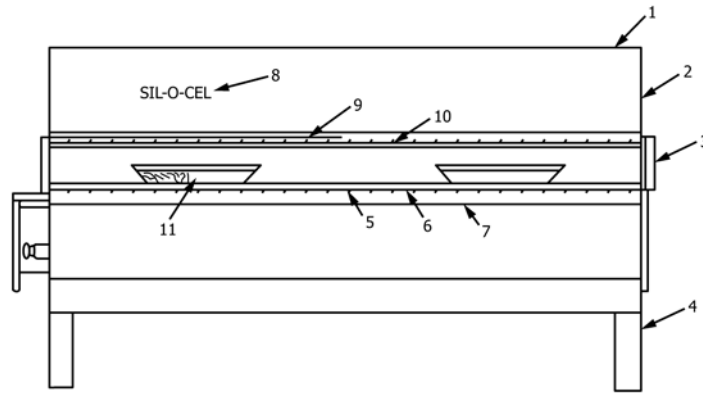

NOTE 1—See A1.1 for further description.

- | | |
|--------------------------------------|--|
| 1. Outer shell (stainless steel) | 7. Outer protection tube |
| 2. End plate (Transite) ⁴ | 8. Sil-O-Cel ⁵ insulation |
| 3. End plate (quartz) | 9. Control thermocouple (platinum/rhodium) |
| 4. Stand | 10. Heating element wire |
| 5. Inner protection tube | 11. Specimen tray |
| 6. Heating element tube | |

FIG. 1 Liquidus Furnace (Method A)

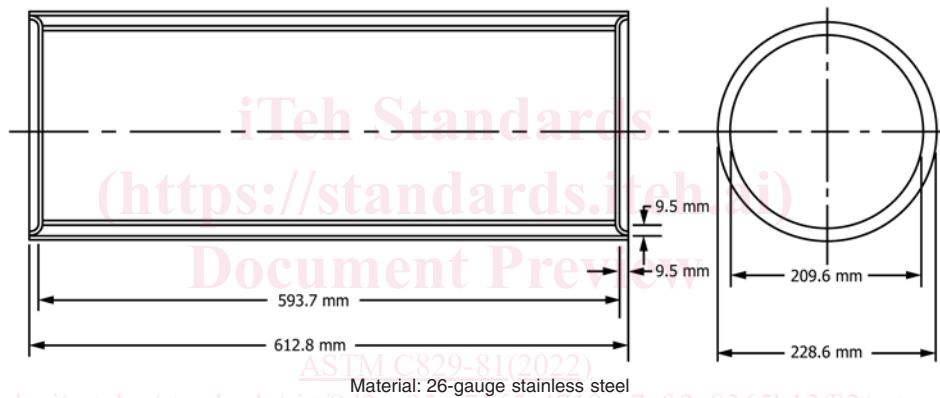

Material: 26-gauge stainless steel

FIG. 2 Liquidus Furnace Shell (Method A)

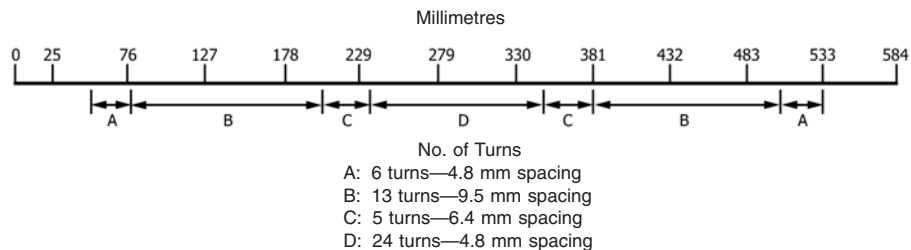
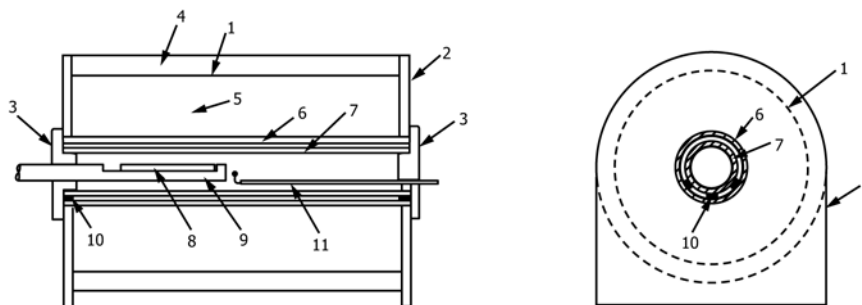

FIG. 3 Recommended Liquidus Furnace Winding (Method A)

used for the inner core winding. The basic furnace temperature level is achieved by controlling power to both inner and outer core windings. The slope of the gradient is achieved by adjusting power input to the outer core winding only. The established temperature gradient is then maintained by controlling power to the inner core winding only.

4.1.3 *Temperature-Measuring Equipment*—Furnace temperatures shall be measured with calibrated Type R or S thermocouples in conjunction with a calibrated potentiometer, or other comparable instrumentation, capable of measurements

within 0.5 °C. In addition to control thermocouples, Method A requires an unshielded supported thermocouple for insertion into the furnace chamber to determine temperature gradients, and Method B requires five thermocouples mounted in the specimen support fixture as shown in Fig. 6. An alternative method is to attach (spot weld) the thermocouples to a fixed platinum or platinum alloy plate which supports the tray or perforated plate. A solid-state digital thermometer capable of the measurement accuracy specified may be used for temperature measurement.



NOTE 1—See A1.2 for further description.

- | | |
|---|----------------------------------|
| 1. Stainless steel shell | 7. Inner heating element tube |
| 2. End plates (Transite ⁴) | 8. Perforated platinum tray |
| 3. End seals (Fiberfrax ⁹) | 9. Mullite tube of riding device |
| 4. Insulating cover (Fiberfrax ⁶) | 10. Alumina spacers |
| 5. Refractory or Sil-O-Cel insulation | 11. Controlling thermocouple |
| 6. Outer heating element tube | |

FIG. 4 Liquidus Furnace (Method B)

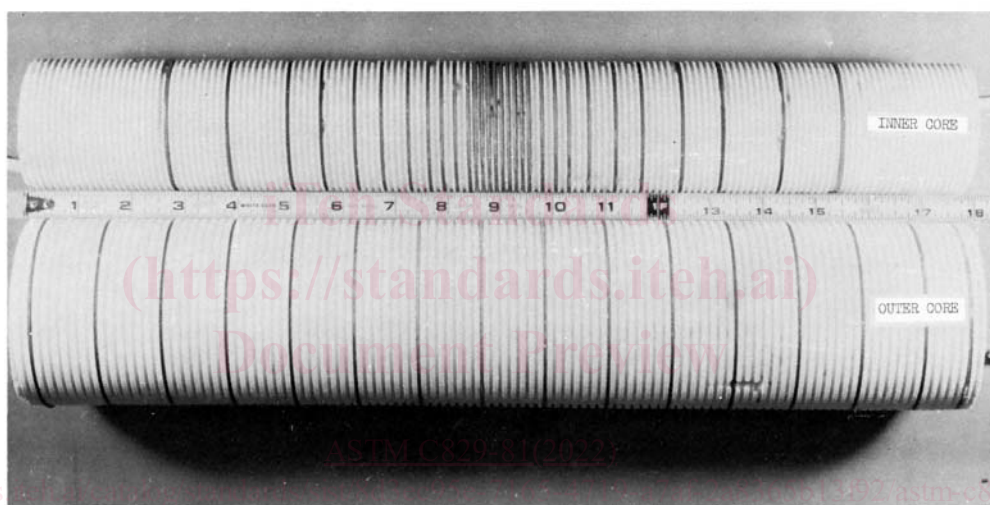
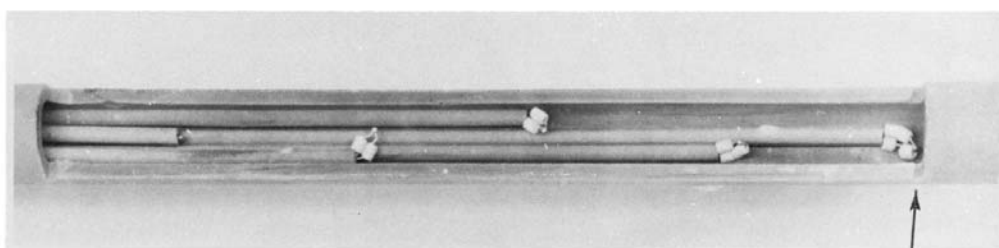

FIG. 5 Liquidus Furnace Heating Cores (Method B)



NOTE 1—Hottest thermocouple positioned at forward edge of cut-away section of mullite tube.

FIG. 6 Specimen Support Fixture (Method B)

4.1.4 *Microscope*—A microscope capable of resolution of at least 5 μm at 100× is required. A petrographic microscope is preferred for ease of crystal identification under polarized light.

4.1.5 *Additional Equipment for Method A:*

4.1.5.1 Laboratory stand to support thermocouple horizontally (see Fig. 7).

4.1.5.2 Trough-type platinum boats (see Fig. 8 and Annex A2).

4.1.5.3 Reshaping die for trough-type boats (see Fig. 8).

4.1.5.4 Stainless steel mortar and pestle. (*The stainless steel must be magnetic.*)

4.1.5.5 Sieve, U.S. Standard, No. 20 (850 μm) with receiver pan.

4.1.5.6 Small horseshoe magnet.

4.1.5.7 Glass vials with covers.

4.1.5.8 Graduated measuring rod.

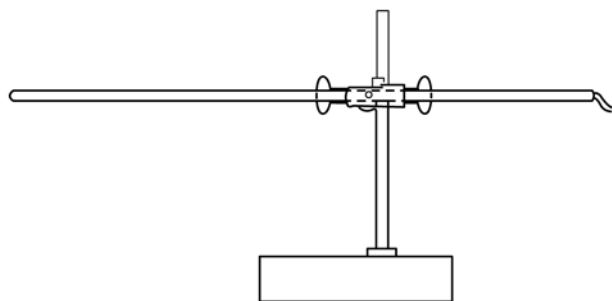

FIG. 7 Thermocouple and Support (Method A)

4.1.5.9 Stainless steel tongs.

4.1.5.10 Other minor items as described in the text.

4.1.6 *Additional Equipment for Method B:*

4.1.6.1 Riding device for simultaneously holding and positioning multiple thermocouples and a perforated platinum tray. This device is provided with leveling screws, a means for lateral adjustment, and a positive stop for precisely locating the boat and thermocouples within the furnace. The device shown in Fig. 9 meets these requirements.

4.1.6.2 Perforated platinum trays (see Fig. 10 and Annex A2).

4.1.6.3 Stainless steel mortar and pestle.

4.1.6.4 Sieves, U.S. Standard, No. 8 (2.36 mm) and No. 12 (1.70 mm) with receiver pan.

4.1.6.5 Glass vials with covers.

4.1.6.6 Stainless steel pointed tongs.

4.1.6.7 Other minor items as shown in illustrations and described in the text.

5. Preparation of Test Specimens

5.1 Select a mass of glass of approximately 70 g. Break the sample into pieces of a size that will fit into the mortar. Clean the sample with acetone, rinse with distilled water, and dry. Clean the mortar and pestle, sieve, and magnet in the same manner (Note 2). Crush the sample, using the mortar and pestle, by using a hammer or other suitable means.

NOTE 2—From this point on, contact with bare hands or other source of contamination must be avoided.

5.2 *Method A*—Pour the crushed sample onto a No. 20 (850 μ m) sieve. Retain the material not passing the sieve and repeat the crushing procedure until all the glass has been reduced to a size to pass through the sieve into the receiver pan. With the test specimen still in the pan, move the magnet throughout the specimen to remove magnetic fragments that may have been introduced during crushing. If not to be tested immediately, place the specimen in a covered glass vial or other suitable container.

5.3 *Method B*—Pour the crushed sample onto a No. 8 (2.36 mm) sieve fitted over a No. 12 (1.70 mm) sieve and receiver pan. Retain only that part of the sample not passing through the No. 12 sieve. That glass retained on the No. 8 sieve may be recrushed if necessary to increase the No. 12 sieve sample size. Discard the fines passing through to the receiver pan. If not to be tested immediately, place the specimen in a covered glass vial or other suitable container.

6. Procedure

6.1 *Method A*—Fill to one-half to three-quarters full two specimen trays that are free of cracks, pits, or adhering glass with the crushed glass specimen. Distribute evenly over the length of each tray. Place the filled trays in the furnace, one on either side of the maximum temperature point, and locate so that their centers are at the predetermined gradient temperature level corresponding to the liquidus temperature, if known. Record the location of the trays in the furnace. Either the single- or the double-core furnace may be used. Modify the double-core furnace design to accommodate two samples by providing two riding devices and means for insertion from both ends of the furnace.

6.2 *Method B*—Use one or two perforated specimen trays that are free of cracks, pits, or adhering glass. Using the pointed stainless steel tongs or tweezers, select chips of the sample from the No. 12 (1.70 mm) sieve and place one in each of the drilled holes in each tray. Position a tray in the cut-away section of the mullite tube on the riding device with the double row of holes forward (toward the hot end), and the forward end of the tray indexed precisely over the most forward of the five thermocouples against the forward edge of the cut-away section, as shown in Fig. 4. An alternative method is to move the furnace into position around a fixed tray. One sample in one tray supported by one riding device may be tested in the double-core furnace. Two samples may be tested simultaneously by modifying the furnace design to provide for insertion from both ends. Carefully feed the riding device containing the tray into the furnace until the prepositioned stop plate is contacted. Close the end opening of the furnace around the riding device with suitable insulation.

6.3 *Treatment Time*—Leave the specimens in the furnace until equilibrium between the crystal and glassy phases is established. The time required is a function of the glass composition. Twenty-four hours is sufficient for many glasses, but some glasses may take days to reach equilibrium. Complete crystallization of the specimen indicates insufficient temperature in heat treatment. Total lack of crystallization indicates insufficient time or excess temperature.

6.4 *Temperature Gradient*—Determine the temperature gradients over the lengths of the specimens at the end of the heating period just prior to removal from the furnace.

6.4.1 *Single-Core Furnace*—Establish a temperature profile over the length of each tray by using a traveling unshielded Type R or S thermocouple supported horizontally as near the top of the trays as practical and centered over their widths. Start the probe at the hotter end of each tray, toward the center of the furnace, and make successive temperature readings along the tray length at 1/2-in. (12.7 mm) intervals. Allow the thermocouple temperature to stabilize in each position as indicated by constancy of temperature over a period of time. Record the temperature of each thermocouple position to the nearest 1 °C as related to tray position, and plot as in Fig. 11.

6.4.2 *Double-Core Furnace*—Obtain the temperature profile as related to tray position from readings of the five Type R or S thermocouples mounted in fixed positions in the riding device.

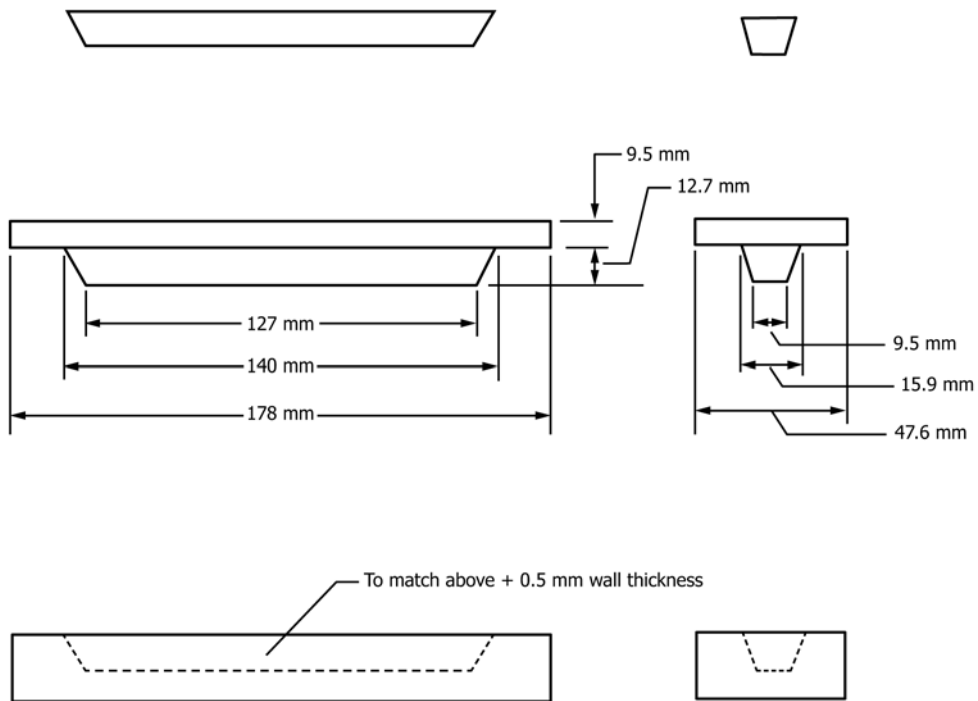

FIG. 8 Platinum Tray and Reforming Die (Method A)

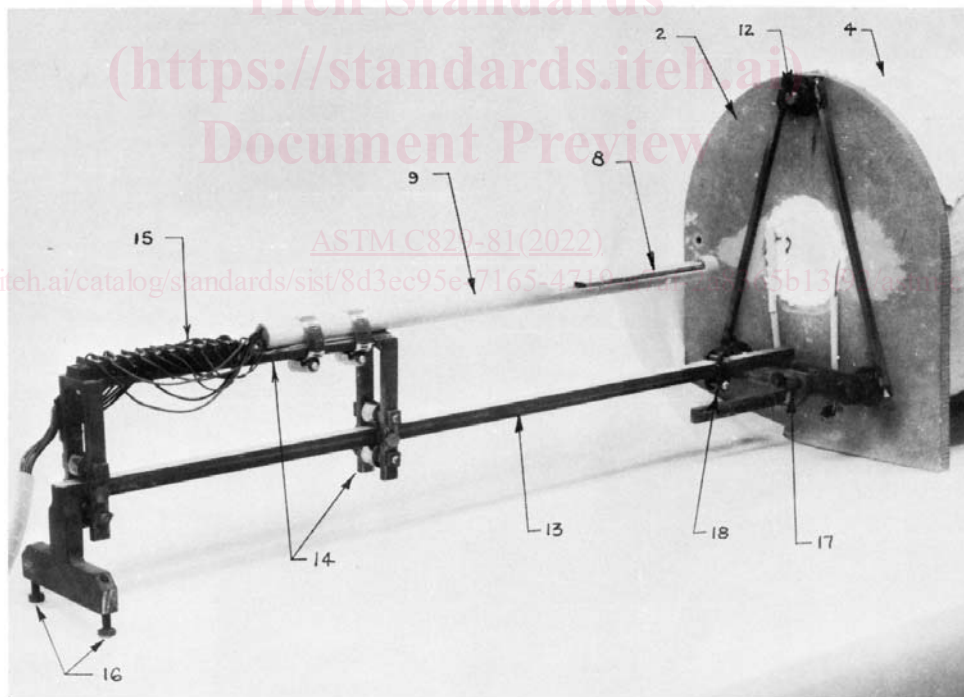

FIG. 9 Riding Device (Method B)

NOTE 1—See A1.2 and Fig. 4 for legend.

6.5 Method A:

6.5.1 Remove the specimens from the furnace, free from the trays, cool, and examine under a microscope for evidence of crystallization. If the single-core furnace has been used for the heat treatment, grasp the trays with smooth-faced forceps and drag outside the furnace onto a heat-resistant flat surface. If the

double-core furnace has been used, retract the riding device from the furnace, remove the tray, and place it on the heat-resistant flat surface. Immediately upon removal and before the glass specimen hardens, bend the sidewalls of the tray slightly inward at 1-in. (25.4 mm) intervals along its length. After the specimen has solidified, but is still quite hot,