



Designation: D6671/D6671M – 22

Standard Test Method for Mixed Mode I-Mode II Interlaminar Fracture Toughness of Unidirectional Fiber Reinforced Polymer Matrix Composites¹

This standard is issued under the fixed designation D6671/D6671M; the number immediately following the designation indicates the year of original adoption or, in the case of revision, the year of last revision. A number in parentheses indicates the year of last reapproval. A superscript epsilon (ϵ) indicates an editorial change since the last revision or reapproval.

1. Scope

1.1 This test method covers the determination of interlaminar fracture toughness, G_c , of continuous fiber-reinforced composite materials at various Mode I to Mode II loading ratios using the Mixed-Mode Bending (MMB) Test.

1.2 This test method is limited to use with composites consisting of unidirectional carbon fiber tape laminates with brittle and tough single-phase polymer matrices. This test method is further limited to the determination of fracture toughness as it initiates from a delamination insert. This limited scope reflects the experience gained in round robin testing. This test method may prove useful for other types of toughness values and for other classes of composite materials; however, certain interferences have been noted (see Section 6). This test method has been successfully used to test the toughness of both glass fiber composites and adhesive joints.

1.3 *Units*—The values stated in either SI units or inch-pound units are to be regarded separately as standard. The values stated in each system are not necessarily exact equivalents; therefore, to ensure conformance with the standard, each system shall be used independently of the other, and values from the two systems shall not be combined.

1.4 *This standard does not purport to address all of the safety concerns, if any, associated with its use. It is the responsibility of the user of this standard to establish appropriate safety, health, and environmental practices and determine the applicability of regulatory limitations prior to use.*

1.5 *This international standard was developed in accordance with internationally recognized principles on standardization established in the Decision on Principles for the Development of International Standards, Guides and Recommendations issued by the World Trade Organization Technical Barriers to Trade (TBT) Committee.*

¹ This test method is under the jurisdiction of ASTM Committee D30 on Composite Materials and is the direct responsibility of Subcommittee D30.06 on Interlaminar Properties.

Current edition approved Feb. 1, 2022. Published March 2022. Originally approved in 2001. Last previous edition approved in 2019 as D6671/D6671M – 19. DOI: 10.1520/D6671_D6671M-22.

2. Referenced Documents

2.1 ASTM Standards:²

- D883 Terminology Relating to Plastics
- D2651 Guide for Preparation of Metal Surfaces for Adhesive Bonding
- D2734 Test Methods for Void Content of Reinforced Plastics
- D3171 Test Methods for Constituent Content of Composite Materials
- D3878 Terminology for Composite Materials
- D5229/D5229M Test Method for Moisture Absorption Properties and Equilibrium Conditioning of Polymer Matrix Composite Materials
- D5528 Test Method for Mode I Interlaminar Fracture Toughness of Unidirectional Fiber-Reinforced Polymer Matrix Composites
- E4 Practices for Force Calibration and Verification of Testing Machines
- E6 Terminology Relating to Methods of Mechanical Testing
- E122 Practice for Calculating Sample Size to Estimate, With Specified Precision, the Average for a Characteristic of a Lot or Process
- E177 Practice for Use of the Terms Precision and Bias in ASTM Test Methods
- E456 Terminology Relating to Quality and Statistics

3. Terminology

3.1 Terminology D3878 defines terms relating to high-modulus fibers and their composites. Terminology D883 defines terms relating to plastics. Terminology E6 defines terms relating to mechanical testing. Terminology E456 and Practice E177 define terms relating to statistics. In the event of conflict between terms, Terminology D3878 shall have precedence over the other terminology standards.

NOTE 1—If the term represents a physical quantity, its analytical dimensions are stated immediately following the term (or letter symbol) in fundamental dimension form, using the following ASTM standard symbology for fundamental dimensions, shown within square brackets: $[M]$ for mass, $[L]$ for length, $[T]$ for time, $[u]$ for thermodynamic temperature,

² For referenced ASTM standards, visit the ASTM website, www.astm.org, or contact ASTM Customer Service at service@astm.org. For *Annual Book of ASTM Standards* volume information, refer to the standard's Document Summary page on the ASTM website.

and [nd] for non-dimensional quantities. Use of these symbols is restricted to analytical dimensions when used with square brackets, as the symbols may have other definitions when used without the brackets.

3.2 Definitions of Terms Specific to This Standard:

3.2.1 *crack opening mode (Mode I)*, n —fracture mode in which the delamination faces open away from each other and no relative crack face sliding occurs.

3.2.2 *crack sliding mode (Mode II)*, n —fracture mode in which the delamination faces slide over each other in the direction of delamination growth and no relative crack face opening occurs.

3.2.3 *mixed-mode fracture toughness*, G_c [M/T^2], n —the critical value of strain energy release rate, G , for delamination growth in mixed-mode.

3.2.4 *mixed-mode ratio*, G_I/G_{II} [nd], n —the ratio of Mode I strain energy release rate to Mode II strain energy release rate.

3.2.5 *mode mixture*, G_{II}/G [nd], n —fraction of Mode II to total strain energy release rate.

3.2.5.1 *Discussion*—The mixed-mode ratio, G_I/G_{II} , is at times referred to instead of the mode mixture.

3.2.6 *Mode I strain energy release rate*, G_I [M/T^2], n —the loss of strain energy associated with Mode I deformation in the test specimen per unit of specimen width for an infinitesimal increase in delamination length, da , for a delamination growing under a constant displacement.

3.2.7 *Mode II strain energy release rate*, G_{II} [M/T^2], n —the loss of strain energy associated with Mode II deformation in the test specimen per unit of specimen width for an infinitesimal increase in delamination length, da , for a delamination growing under a constant displacement.

3.2.8 *strain energy release rate*, G [M/T^2], n —the loss of strain energy, dU , in the test specimen per unit of specimen width for an infinitesimal increase in delamination length, da , for a delamination growing under a constant displacement; in mathematical form,

$$G = -\frac{1}{b} \frac{dU}{da} \quad (1)$$

where:

- a = delamination length, mm [in.],
- b = width of specimen, mm [in.],
- G = total strain energy release rate, kJ/m^2 [in.-lbf/in.²], and
- U = total elastic strain energy in the test specimen, N-mm [in.-lbf].

3.3 Symbols:

- a = delamination length, mm [in.]
- a_0 = initial delamination length, mm [in.]
- a_{1-25} = propagation delamination lengths, mm [in.]
- b = width of specimen, mm [in.]
- b_{cal} = width of calibration specimen, mm [in.]
- c = lever length of the MMB test apparatus, mm [in.]
- c_g = lever length to center of gravity, mm [in.]
- C = compliance, δ/P , mm/N [in./lbf]

- C_{cal} = calibration specimen compliance, δ/P , mm/N [in./lbf]
- C_{sys} = system compliance, δ/P , mm/N [in./lbf]
- CV = coefficient of variation, %
- E_{11} = longitudinal modulus of elasticity measured in tension, MPa [psi]
- E_{22} = transverse modulus of elasticity, MPa [psi]
- E_{cal} = modulus of calibration bar, MPa [psi]
- E_{If} = modulus of elasticity in the fiber direction measured in flexure, MPa [psi]
- G = total strain energy release rate, kJ/m^2 [in.-lbf/in.²]
- G_{13} = shear modulus out of plane, MPa [psi]
- G_{12} = shear modulus in plane, MPa [psi]
- G_I = opening (Mode I) component of strain energy release rate, kJ/m^2 [in.-lbf/in.²]
- G_{II} = shear (Mode II) component of strain energy release rate, kJ/m^2 [in.-lbf/in.²]
- G_{II}/G = mode mixture
- G_c = total mixed-mode fracture toughness, kJ/m^2 [in.-lbf/in.²]
- G_c^{est} = estimated value of total mixed-mode fracture toughness, kJ/m^2 [in.-lbf/in.²]
- h = half thickness of test specimen, mm [in.]
- L = half-span length of the MMB test apparatus, mm [in.]
- m = slope of the load displacement curve, N/mm [lbf/in.]
- m_{cal} = slope of the load displacement curve from calibration test, N/mm [lbf/in.]
- n = number of specimens
- P = applied load, N [lbf]
- $P_{5\%/max}$ = critical load at 5%/max point of loading curve, N [lbf]
- P_{est} = estimated value of critical load, N [lbf]
- P_g = weight of lever and attached apparatus, N [lbf]
- P_{nl} = critical load at nonlinear point of loading curve, N [lbf]
- P_{tab} = expected load on the loading tab, N [lbf]
- P_{vis} = critical load when delamination is observed to grow, N [lbf]
- S_{n-1} = standard deviation
- t = thickness of calibration bar, mm [in.]
- U = strain energy, N-mm [in.-lbf]
- V = fiber volume fraction, %
- xi = measured or derived property for an individual specimen from the sample population
- \bar{x} = sample mean (average)
- α = mode mixture transformation parameter for setting lever length
- β = non-dimensional crack length correction for mode mixture
- χ = crack length correction parameter,

$$\chi = \sqrt{\frac{E_{11}}{11G_{13}} \left\{ 3 - 2 \left(\frac{\Gamma}{1+\Gamma} \right)^2 \right\}}$$

- δ = load point deflection, mm [in.]
- δ_{est} = estimated load point deflection, mm [in.]
- δ_{max} = maximum allowable load point of deflection, mm [in.]
- Γ = transverse modulus correction parameter,

$$\Gamma = 1.18 \frac{\sqrt{E_{11}E_{22}}}{G_{13}}$$

4. Summary of Test Method

4.1 The Mixed-Mode Bending (MMB) test apparatus shown in Fig. 1 is used to load split laminate specimens to determine the delamination fracture toughness at various ratios of Mode I to Mode II loading. The composite test specimen, shown in Fig. 2, consists of a rectangular, uniform thickness, unidirectional laminated composite specimen, containing a nonadhesive insert at the midplane which serves as a delamination initiator. Loading forces are applied to the MMB specimen via tabs that are applied near the ends of the delaminated section of the specimen and through rollers that bear against the specimen in the nondelaminated region. The base of the MMB apparatus holds the specimen stationary while the MMB lever loads the specimen. The base attaches to the bottom specimen tab and also bears on the specimen near the far end with a roller. The lever attaches to the top tab and bears down on the specimen halfway between the base roller and the tabs. The lever roller acts as a fulcrum so by pushing down on the lever arm opposite the tab, the tab is pulled up. The length of the lever arm, *c*, can be changed to vary the ratio of the load pulling on the tab to the load bearing through the roller, thus changing the mode mixture of the test. The load shall be applied to the lever such that the load remains vertical during the loading process. To reduce geometric nonlinear effects as a result of lever rotation, the lever shall be loaded such that the height of loading is slightly above the pivot point where the lever attaches to the test specimen (1, 2).³

4.2 A record of the applied load versus opening displacement is recorded on an *x-y* recorder, or equivalent real-time plotting device or stored digitally and post-processed. The interlaminar fracture toughness, *G_c*, and mode mixture, *G_{II}/G_I*, are calculated from critical loads read from the load displacement curve.

5. Significance and Use

5.1 Susceptibility to delamination is one of the major weaknesses of many advanced laminated composite structures. Knowledge of the interlaminar fracture resistance of composites is useful for product development and material selection.

³ The boldface numbers in parentheses refer to the list of references at the end of this standard.

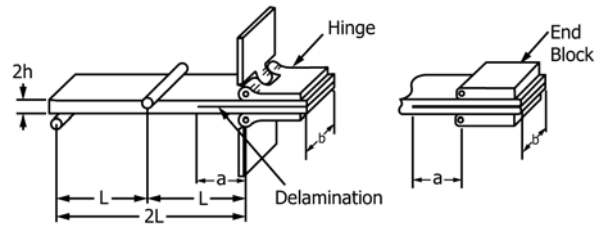

FIG. 2 MMB Test Variables

Since delaminations can be subjected to and extended by loadings with a wide range of mode mixtures, it is important that the composite toughness be measured at various mode mixtures. The toughness contour, in which fracture toughness is plotted as a function of mode mixtures (see Fig. 3), is useful for establishing failure criterion used in damage tolerance analyses of composite structures made from these materials.

5.2 This test method can serve the following purposes:

5.2.1 To establish quantitatively the effects of fiber surface treatment, local variations in fiber volume fraction, and processing and environmental variables on *G_c* of a particular composite material at various mode mixtures,

5.2.2 To compare quantitatively the relative values of *G_c* versus mode mixture for composite materials with different constituents, and

5.2.3 To develop delamination failure criteria for composite damage tolerance and durability analyses.

5.3 This method can be used to determine the following delamination toughness values:

5.3.1 *Delamination Initiation*—Two values of delamination initiation shall be reported: (1) at the point of deviation from linearity in the load-displacement curve (NL) and (2) at the point at which the compliance has increased by 5 % or the load has reached a maximum value (5%/max) depending on which occurs first along the load deflection curve (see Fig. 4). Each definition of delamination initiation is associated with its own value of *G_c* and *G_{II}/G_I* calculated from the load at the corresponding critical point. The 5%/Max *G_c* value is typically the most reproducible of the three *G_c* values. The NL value is, however, the more conservative number. When the option of collecting propagation values is taken (see 5.3.2), a third initiation value may be reported at the point at which the delamination is first visually observed to grow on the edge of the specimen. The VIS point often falls between the NL and the 5%/Max points.

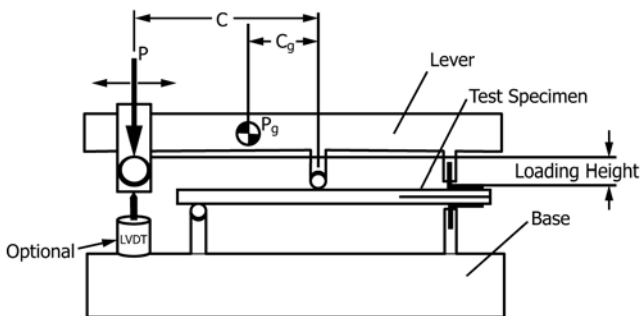

FIG. 1 MMB Apparatus

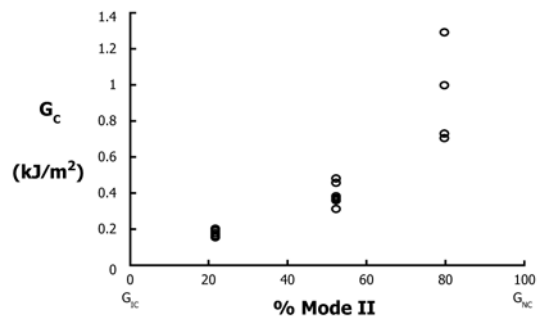

FIG. 3 Mixed-Mode Summary Graph

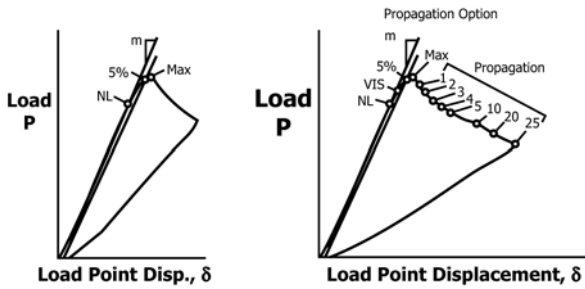

FIG. 4 Load-Displacement Curves

5.3.2 Propagation Option—In the MMB test, the delamination will grow from the insert in either a stable or an unstable manner depending on the mode mixture being tested. As an option, propagation toughness values may be collected when delaminations grow in a stable manner. Propagation toughness values are not attainable when the delamination grows in an unstable manner. Propagation toughness values may be heavily influenced by fiber bridging which is an artifact of the zero-degree-type test specimen (3-5). Since they are often believed to be artificial, propagation values must be clearly marked as such when they are reported. One use of propagation values is to check for problems with the delamination insert. Normally, delamination toughness values rise from the initiation values as the delamination propagates and fiber bridging develops. When toughness values decrease as the delamination grows, a poor delamination insert is often the cause. The delamination may be too thick or deformed in such a way that a resin pocket forms at the end of the insert. For accurate initiation values, a properly implanted and inspected delamination insert is critical (see 8.2).

5.3.3 Precracked Toughness—Under rare circumstances, toughness may decrease from the initiation values as the delamination propagates (see 5.3.2). If this occurs, the delamination should be checked to ensure that it complies with the insert recommendations found in 8.2. Only after verifying that the decreasing toughness was not due to a poor insert, should precracking be considered as an option. With precracking, a delamination is first extended from the insert in Mode I, Mode II, or mixed mode. The specimen is then reloaded at the desired mode mixture to obtain a toughness value.

6. Interferences

6.1 Linear elastic behavior is assumed in the calculation of G_c used in this test method. This assumption is valid when the zone of damage or nonlinear deformation at the delamination front, or both, is small relative to the smallest specimen dimension, which is typically the specimen thickness for the MMB test.

6.2 The application to other materials, layups, and architectures is the same as described in Test Method D5528.

6.3 The nonlinear (NL) initiation value of toughness is normally the more conservative value, but a few materials have exhibited lower propagation toughness values, particularly in the high Mode II regime. In the high Mode II regime, the delamination growth is often unstable, precluding propagation toughness values from being determined. The use of initiation

toughness values could result in nonconservative growth predictions in these select materials. The use of longer initial delaminations increases the tendency for stable delamination growth.

7. Apparatus

7.1 The mixed-mode bending fixture, as seen in Fig. 5, uses a lever to load the MMB specimen. Using one applied load at the end of the lever, a downward load is applied to the specimen center creating Mode II, while an upward force is applied to the split end of the laminate creating Mode I. Machine drawings for an example of MMB apparatus may be found in Appendix X2, but other designs that perform the necessary functions are acceptable. The half-span length of the MMB Apparatus L (see Fig. 2) shall be 50 mm [2 in.]. To keep geometric nonlinear effects small, the loading height (the height of the loading point above the hinge point attaching the lever to the test specimen, as shown in Fig. 1) shall be 0.3 L, and the applied load shall remain vertical as the apparatus is loaded. The load application to the lever and to the test specimen should allow sliding with minimal friction. In the pictured apparatus, this is accomplished with roller bearings, but equivalent means are acceptable.

7.2 **Testing Machine**—A properly calibrated test machine shall be used which can be operated in a displacement control mode with a constant displacement rate in the range of 0.5 to 5.0 mm/min [0.02 to 0.20 in./min]. The testing machine shall conform to the requirements of Practices E4. The testing

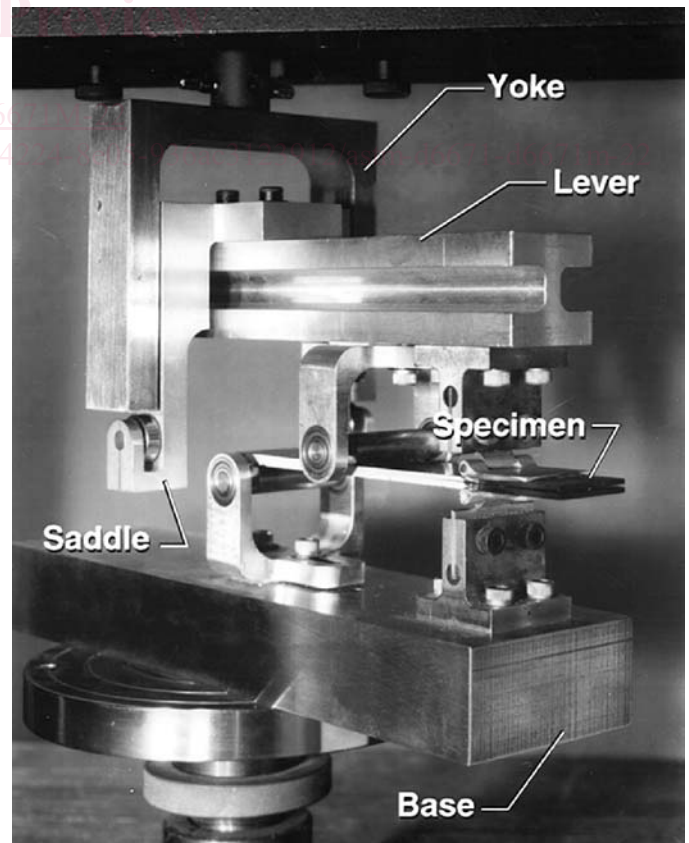

FIG. 5 Mixed-Mode Bending Fixture

machine shall be equipped with a clevis which can be attached to the loading yoke of the MMB apparatus and an anvil on which the base of the MMB apparatus can be placed.

7.3 Load Indicator—The testing machine load-sensing device shall be capable of indicating the total load carried by the test specimen. This device shall be essentially free from inertia lag at the specified rate of testing and shall indicate the load with an accuracy over the load range(s) of interest of within $\pm 1\%$ of the indicated value.

7.4 Load Point Displacement Indicator—The load point displacement may be taken from the crosshead separation of the load frame or from an external gauge attached to the MMB apparatus. If the crosshead separation is used as the measurement of load point displacement, correction must be made for the compliance of the loading system, C_{sys} which includes the compliance of the load frame and the MMB apparatus. The compliance of the loading system must be measured at each lever length c to be used during testing (see 11.5). The C_{sys} will be used in the equation for specimen modulus to correct for the load system compliance.

7.4.1 The load point displacement may be obtained from a properly calibrated external gauge or transducer attached to the MMB apparatus such as the linearly variable displacement transducer (LVDT) shown in Fig. 1. The displacement indicator shall indicate the load point displacement with an accuracy of within $\pm 1\%$ of the indicated value once the delamination occurs. If the load point displacement is taken from an external gauge or transducer, the C_{sys} value should be set to zero in the specimen modulus equation (Eq 10).

7.5 Load Versus Load Point Displacement Record—An $x-y$ plotter, or similar device, shall be used to make a permanent record during the test of load versus opening displacement at the point of load application. Alternatively, the data may be stored digitally and postprocessed.

7.6 Optical Microscope (Only for Propagation Option)—A traveling optical microscope with a magnification no greater than 70 \times , or an equivalent magnifying device, shall be positioned on one side of the specimen to observe the delamination front as it extends along one edge during the test visually. This device shall be capable of pinpointing the delamination front with an accuracy of at least ± 0.5 mm [± 0.02 in.]. A mirror may be used to determine any discrepancy visually in delamination onset from one side of the specimen to the other. Other methods, such as crack length gauges bonded to a specimen edge, may be used to monitor delamination length provided their accuracy is as good as the optical microscope so that delamination length may be measured to the accuracy specified above.

7.7 The micrometer(s) shall use a suitable size diameter ball-interface on irregular surfaces such as the bag side of a laminate and a flat anvil interface on machined edges or very smooth tooled surfaces. The accuracy of the instruments shall be suitable for reading to within 1% of the sample width and thickness. For typical specimen geometries, an instrument with an accuracy of ± 0.025 mm [0.001 in.] is desirable for thickness and width measurements.

8. Sampling and Test Specimens

8.1 Test laminates must contain an even number of plies, and shall be unidirectional, with delamination growth occurring in the 0° direction.

8.2 A nonadhesive insert shall be inserted at the midplane of the laminate during layup to form an initiation site for the delamination (see Fig. 6 and Fig. 7). The film thickness shall be no greater than $13\ \mu\text{m}$ [0.0005 in.]. Specimens should not be precracked. By not precracking, an initiation value free of fiber bridging may be obtained (see 5.3.2). A polymer film is recommended for the insert to avoid problems with folding or crimping at the cut end of the insert as was observed for aluminum foil inserts during round robin testing of DCB specimen, Test Method D5528 (6). For epoxy matrix composites cured at relatively low temperatures, 177°C [350°F] or less, a thin film made of polytetrafluoroethylene (PTFE) is recommended. For composites with polyimide, bismaleimide, or thermoplastic matrices that are manufactured at relatively high temperatures, greater than 177°C [350°F], a thin polyimide film is recommended. For materials outside the scope of this standard, different film materials may be required. If a polyimide film is used, the film shall be painted or sprayed with a mold release agent before it is inserted in the laminate. (Mold release agents containing silicone may contaminate the laminate by migration through the individual layers. It is often helpful to coat the film at least once and then bake the film before placing the film on the composite. This will help to prevent silicone migration within the composite.)

8.3 Specimen Dimensions:

8.3.1 As indicated in Fig. 6 and Fig. 7, the overall length of the specimen is not critical but will normally be around 137 mm [5.5 in.]. The width of the specimen shall be between 20 to 25 mm [0.8 to 1.0 in.], inclusive.

NOTE 2—Round robin testing on narrow and wide DCB specimens, Test Method D5528, yielded similar results. Since the MMB specimen is similar, the width of the MMB specimen is not considered a critical parameter.

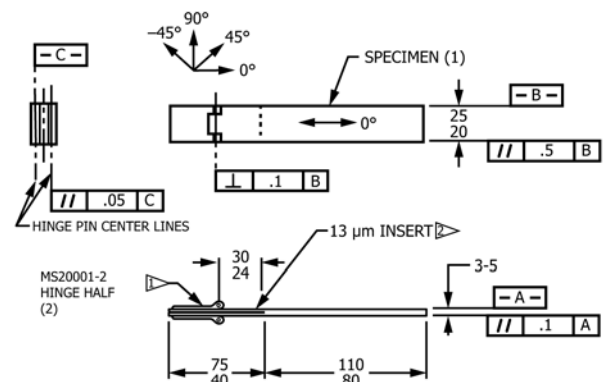

- NOTES:
- SOLID END BLOCKS OF SAME DIMENSIONS ARE AN ACCEPTABLE ALTERNATIVE TO PIANO HINGES.
 - SEE SECTION 8.2 FOR SUGGESTED INSERT MATERIALS.
 - ALL DIMENSIONS IN MILLIMETERS.
 - BOND HINGES/END BLOCKS USING APPROPRIATE STRUCTURAL ADHESIVE.
 - DRAWING INTERPRETATION PER ANSI Y14.5-1982 AND ANSI/ASME B46.1-1986.
 - PLY ORIENTATION TOLERANCE TO 5° RELATIVE TO -B-.

FIG. 6 Specimen—MMB Test (SI Units)

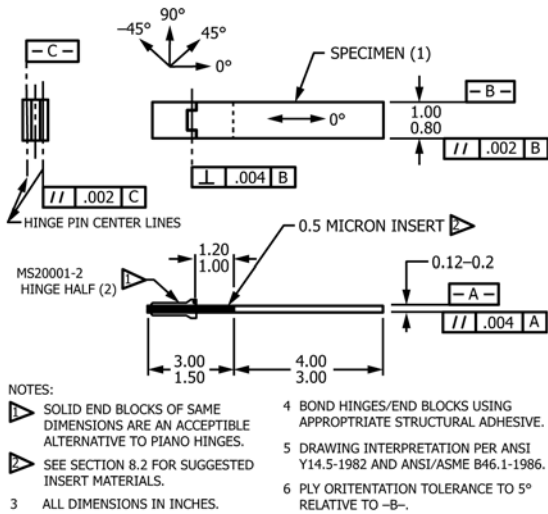

FIG. 7 Specimen—MMB Test (Inch-Pound Units)

8.3.2 Panels shall be manufactured, and specimens cut from the panels as shown in Fig. 6 and Fig. 7. The insert length is approximately 50 mm [2 in.] which corresponds to an initial delamination length of approximately 25 mm [1 in.] plus the extra length required to apply the tabs. The end of the insert should be accurately located and marked on the panel before cutting specimens.

8.4 The laminate thickness shall normally be between 3 and 5 mm [0.12 and 0.2 in.]. The variation in thickness for any given specimen shall not exceed 0.1 mm [0.004 in.]. The thickness of the specimen may need to be increased to avoid large applied displacements and therefore geometric nonlinear errors as described in 13.2. Eq 2 and 3 can be used to select a specimen thickness to achieve a permissible amount of applied displacement.

$$\delta_{est} = \frac{P_{est}}{8bE_{11}h^3L^2} \left[\begin{array}{l} 4(3c - L)^2(a + h\chi)^3 \\ + (c + L)^2(2L^3 + 3(a + 0.42h\chi)^3) \end{array} \right] \quad (2)$$

$$P_{est} = \sqrt{\frac{\frac{4}{3}G_c^{est}b^2E_{11}h^3L^2}{(3c - L)^2(a + h\chi)^2 + \frac{3}{4}(c + L)^2(a + 0.42h\chi)^2}} \quad (3)$$

where:

- a = delamination length, mm [in.],
- b = width of specimen, mm [in.],
- c = lever length of the MMB test apparatus, mm [in.],
- E_{11} = longitudinal modulus of elasticity measured in tension, MPa [psi],
- E_{22} = transverse modulus of elasticity, MPa [psi],
- G_{13} = shear modulus out of plane, MPa [psi],
- G_c^{est} = estimated value of total mixed-mode fracture toughness, kJ/m² [in.-lbf/in.²],
- h = half thickness of test specimen, mm [in.],

- L = half-span length of the MMB test apparatus, mm [in.],
- P_{est} = estimated value of critical load, N [lbf],
- χ = crack length correction parameter,
- δ_{est} = estimated load point of deflection, mm [in.], and
- Γ = transverse modulus correction parameter.

8.5 It is recommended that void content and fiber volume be reported. Void content may be determined using the equations of Test Methods D2734. The fiber volume fraction may be determined using a digestion process per Test Methods D3171.

8.6 *Sampling*—Test at least five specimens per test condition unless valid results can be gained through the use of fewer specimens, such as in the case of a designed experiment. For statistically significant data, the procedures outlined in Practice E122 should be consulted. The method of sampling shall be reported.

8.7 *Load Introduction*—Load shall be introduced through applied tabs. The tabs may be made from piano hinges as shown in Fig. 6 and Fig. 7, or end blocks. The tabs shall be applied such that the initial delamination length, measured from the load line to the end of the insert, is $0.45L < a < L - 3h$. The tabs shall be at least as wide as the specimen (20 to 25 mm [0.8 to 1.0 in.]). The tabs shall be made of a metal with modulus greater than 60 000 MPa, and shall be capable of sustaining the applied load without incurring damage across the width. The tabs may be adhesively bonded or mechanically applied. The load transfer region should not extend more than 3 mm [0.1 in.] past the center of the loading axis toward the delamination tip to reduce specimen stiffening effects. To reduce geometric nonlinearity, the center of the loading axis shall also be within 4 mm [0.15 in.] of the midplane of the specimen leg. An estimate of the load to be carried by the tab in the MMB test can be calculated from estimated values of modulus, E_{11} and toughness, G_c , using the following equation:

$$P_{tab} = \frac{4c}{a} \sqrt{\frac{b^2h^3E_{11}G_c^{est}}{117c^2 - 54cL + 21L^2}} \quad (4)$$

where:

P_{tab} = expected load on the loading tab, N [lbf].

8.7.1 *Bonded Tabs*—The bonding surfaces of the tabs and the specimen shall be properly cleaned before bonding to ensure load transfer without debonding of the tabs from the specimen during the test. If debonding occurs, the specimen should not be reused if there is physical evidence that a delamination initiated when the bond failed, or if an increased compliance is observed upon reloading.

8.7.1.1 *Surface Preparations of the Specimen*—The bonding surface of the specimen may be lightly grit blasted or scrubbed with sandpaper, then wiped clean with a volatile solvent, such as acetone or methylethylketone (MEK), to remove any contamination.

8.7.1.2 *Surface Preparation of the Loading Tabs*—The loading tabs may be cleaned as in 8.7.1.1. If this procedure results in a bond failure between the specimen and the tabs, it may be necessary to apply a more sophisticated cleaning procedure based on degreasing and chemical etching. Consult Guide

D2651 for the surface preparation procedure that is most appropriate for the particular metal used for the tabs.

8.7.1.3 *Bonding*—Bonding of the tabs to the specimen shall be performed immediately after surface preparation. Room temperature cure adhesives are recommended. In some cases, a “superglue,” such as cyanoacrylate, has been found to be sufficient. The adhesive may benefit from a postcure if the specimens are dried after the tabs are mounted. To control bondline thickness, glass beads may be added to the adhesive or other forms of bondline control may be used when needed. The loading tabs shall be aligned parallel with the specimen and with each other and held in position with clamps while the adhesive cures.

8.7.2 *Mechanically Attached Tabs*—Tabs must be attached so that load is uniformly transferred across the width of the specimen in the gauge region (7). The specimen must not be clamped in any way that would tend to bend the specimen across the width.

9. Calibration

9.1 The accuracy of all measuring equipment shall have certified calibrations that are current at the time of use of the equipment.

10. Conditioning

10.1 *Standard Conditioning Procedure*—Condition per Procedure C of Test Method **D5229/D5229M** unless a different environment is specified as part of the experiment. Store and test specimens at Standard Laboratory Atmosphere of 23 ± 3 °C [73 ± 5 °F] and 50 ± 10 % relative humidity.

10.2 *Drying*—If interlaminar fracture toughness data are desired for laminates in a dry condition, use Procedure D of Test Method **D5229/D5229M**.

NOTE 3—The term “moisture,” as used in Test Method **D5229/D5229M** includes not only the vapor of a liquid and its condensate, but the liquid itself in large quantities, as for immersion.

10.3 If no explicit conditioning process is performed the specimen conditioning process shall be reported as “unconditioned” and the moisture content as “unknown.”

11. Procedure

11.1 Measure the width and thickness of each specimen to the nearest 0.025 mm [0.001 in.] at the midpoint and at 25 mm [1 in.] from either end. The variation in thickness along the length of the specimen shall not exceed 0.1 mm [0.004 in.]. The average values of the width and thickness measurements shall be recorded.

11.2 (*Propagation Option Only*)—Mark the end of the delamination insert. Do not try to locate the end of the insert by opening the specimen. If it is difficult to locate the end of the insert from observation of the specimen edge, or from the original mark on the panel, try the following: (1) rub the edge of the specimen in the local area near the insert with a soft lead pencil, or (2) polish the edge of the specimen.

11.3 (*Propagation Option Only*)—Coat both edges of the specimen just ahead of the insert with a thin layer of water-soluble typewriter correction fluid, or equivalent, to aid in

visual detection of delamination onset. Mark the end of the insert on either edge with a thin vertical line. Also mark every 1 mm [$1/16$ in.] for the first 5 mm [$1/4$ in.] past the end of the insert and every 5 mm [$1/4$ in.] thereafter up to 25 mm [1 in.].

11.4 Set the length of the lever, c , of the MMB apparatus to produce the desired mode mixture, G_{II}/G . The following equation gives the correct lever length (8).

$$c = \frac{12\beta^2 + 3\alpha + 8\beta\sqrt{3\alpha}}{36\beta^2 - 3\alpha}L \quad (5)$$

where:

α = mode mixture transformation parameter for setting lever length, and

β = non-dimensional crack length correction for mode mixture.

The mode mixture transformation parameter for setting lever length, α , and non-dimensional crack length correction for mode mixture, β , are given in Eq 6 and Eq 7, respectively (8):

$$\alpha = \frac{1 - \frac{G_{II}}{G}}{\frac{G_{II}}{G}} = \frac{G}{G_{II}} - 1 \quad (6)$$

$$\beta = \frac{a + \chi h}{a + 0.42\chi h} \quad (7)$$

11.5 Measure the compliance of the loading system C_{sys} , if crosshead displacement is to be used for the load point displacement and the compliance of the loading system has not previously been determined for the current lever length setting.

11.5.1 Use a calibration specimen in the MMB apparatus instead of the MMB test specimen. The calibration specimen should be a rectangular bar made from a homogeneous material with a known modulus value. The calibration specimen shall have tabs applied to one end similar to a MMB specimen and should be at least as stiff as a steel bar with $I = 450 \text{ mm}^4$ [0.001 in.⁴]. Calculate the compliance of the calibration specimen using the following equation.

$$C_{cal} = \frac{2L(c+L)^2}{E_{cal}b_{cal}t^3} \quad (8)$$

where:

b_{cal} = width of calibration specimen, mm [in.],

C_{cal} = compliance of calibration specimen, δ/P , mm/N [in./lbf],

E_{cal} = modulus of the calibration bar (published value), MPa [psi], and

t = thickness of the calibration specimen, mm [in.].

11.5.2 Load the MMB apparatus with calibration specimen inserted and record the load-displacement response. Load the calibration specimen to approximately 75 % of the estimated load given by Eq 3 for the delamination tests to be performed. All input to Eq 3 should be for the test specimen and not the calibration specimen. The delamination length should be the initial delamination length (a_o).

11.5.3 Measure the slope of the loading curve, m_{cal} . Calculate the compliance of the MMB test system using the following equation: