



Standard Specification for Joints for Drain and Sewer Plastic Pipes Using Flexible Elastomeric Seals¹

This standard is issued under the fixed designation D3212; the number immediately following the designation indicates the year of original adoption or, in the case of revision, the year of last revision. A number in parentheses indicates the year of last reapproval. A superscript epsilon (ϵ) indicates an editorial change since the last revision or reapproval.

This standard has been approved for use by agencies of the U.S. Department of Defense.

1. Scope*

1.1 This specification covers joints for plastic pipe systems intended for drain, and gravity sewerage pipe at internal or external pressures less than 25-ft head using flexible watertight elastomeric seals. This specification is intended to cover the test requirements, test methods, and acceptable materials. The test methods described for the joints are not intended to be routine quality control tests but to be reliability or performance requirements.

1.2 The text of this specification references notes, footnotes, and appendixes which provide explanatory material. These notes and footnotes (excluding those in tables and figures) shall not be considered as requirements of the specification.

1.3 The following safety hazards caveat pertains only to the test method portion, paragraph 7.5, of this specification: *This standard does not purport to address all of the safety concerns, if any, associated with its use. It is the responsibility of the user of this standard to establish appropriate safety, health, and environmental practices and determine the applicability of regulatory limitations prior to use.*

1.4 *This international standard was developed in accordance with internationally recognized principles on standardization established in the Decision on Principles for the Development of International Standards, Guides and Recommendations issued by the World Trade Organization Technical Barriers to Trade (TBT) Committee.*

2. Referenced Documents

2.1 *ASTM Standards:*²

D2122 Test Method for Determining Dimensions of Thermoplastic Pipe and Fittings

¹ This specification is under the jurisdiction of ASTM Committee F17 on Plastic Piping Systems and is the direct responsibility of Subcommittee F17.20 on Joining. Current edition approved Dec. 1, 2021. Published March 2022. Originally approved in 1973. Last previous edition approved in 2020 as D3212 – 20 DOI: 10.1520/D3212-21.

² For referenced ASTM standards, visit the ASTM website, www.astm.org, or contact ASTM Customer Service at service@astm.org. For *Annual Book of ASTM Standards* volume information, refer to the standard's Document Summary page on the ASTM website.

F477 Specification for Elastomeric Seals (Gaskets) for Joining Plastic Pipe

F913 Specification for Thermoplastic Elastomeric Seals (Gaskets) for Joining Plastic Pipe

3. Types

3.1 This specification covers two types of joints based on effecting watertightness through compression of an elastomeric seal or ring:

3.1.1 *Push-on Joint*—A joint in which an elastomeric ring gasket is compressed in the annular space between a bell end or socket and a spigot end of pipe.

3.1.2 *Mechanical Joint*—A joint made using mechanical means or devices to develop a pressure seal.

4. Materials

4.1 Material used for elastomeric seal in push-on joints shall meet the requirements of either Specification F477 or F913.

4.2 *Lubricant*, if required, shall be suitable for lubricating the parts of the joints in the assembly. The lubricant shall have no deteriorating effects on the gasket and pipe materials.

5. General Requirements

5.1 Joints shall not leak when subjected to the internal and external hydrostatic tests of Section 7 for a period of 10 min.

5.2 All surfaces of the joint upon or against which the gasket bears shall be smooth and free of cracks, fractures, or imperfections.

5.3 *Drawings*—The manufacturer shall furnish drawings of the joint and gasket if requested by the purchaser.

5.4 The gasket shall be the sole element depended upon to make the joint flexible and watertight. The gasket shall be a continuous elastomeric ring.

5.5 In mechanical joints, the pipe spigot shall have a wall thickness sufficient to withstand, without deformation or collapse, the compressive force exerted when the fitting is tightened.

5.6 Some joint designs provide for the angular deflection of a pipe joint, without reducing watertightness. Where greater

*A Summary of Changes section appears at the end of this standard

deflections are required than permitted by the joint design, suitable fittings must be provided.

5.7 The joint components shall be of such design that they will withstand the forces caused by the compression of the gasket when joined without cracking or fracturing when tested in accordance with the requirements of the pipe manufacturer.

6. Dimensions and Tolerances

6.1 Dimensions of the joint components shall be in accordance with the manufacturer’s standard design dimensions and tolerances. Such dimensions shall be gaged at sufficiently frequent intervals to assure dimensional control and satisfactory joint assembly. The method for measuring these dimensions shall be in accordance with Test Method D2122.

6.2 Gasket dimensions shall be in accordance with the manufacturer’s standard design dimensions and tolerances. The gasket shall be of such size and shape as to provide an adequate compressive force against the spigot and socket after assembly, to effect a positive seal under all combinations of joint and gasket tolerances, when tested in accordance with Section 7.

7. Joint Qualification Requirements

7.1 Assemble a piece of pipe into a bell or fitting as shown in Fig. 1. The gasket shall be lubricated as instructed by the manufacturer. Use water in the absence of other lubricants. Seal the openings, using either solvent cement caps as shown in Fig. 1, or mechanical sealing devices, such as mechanical caps with compression seals or an internal seal placed on each side of the joint. The sealing devices shall be restrained to prevent movement relative to the bell or spigot. If internal seals are to be used, they shall be an appropriate material and size in order to not influence how the joint would seal in the field or when deflected in accordance with 7.3 and 7.4.

7.2 Perform the pressure and vacuum tests as described in 7.5 on two properly joined pipes in straight alignment.

7.3 Deflect the joint to the maximum angular misalignment specified by the manufacturer. With the joint deflected, perform pressure and vacuum tests described in 7.5.

7.4 Using the test fixture shown in Fig. 2, commence measuring deflection when the load contacts the top of the pipe. Apply further load until the point of load application has moved downward 5 % of the pipe outside diameter. Hold this position and perform the tests described in 7.5.

NOTE 1—The 5 % deflection criterion, which was arbitrarily selected for testing convenience, should not be considered as a limitation with respect to in-use deflection.

7.5 Test Methods:

NOTE 2—It is acceptable to perform the vacuum and pressure tests in any order. As an option to seat the gasket, or in referee testing if agreed by all parties, the sequence of tests may be pressure, vacuum, pressure for each condition in 7.2, 7.3, and 7.4.

7.5.1 *Internal Pressure Test*—Fill the assembly with water. External restraints should be provided in the test equipment to prevent separation of the gasket joint under pressure. Apply a pressure of 74 kPa (10.8 psi) (gauge) (25-ft head) for 10 min. Visible leaks in the gasket joint constitute a failure.

7.5.2 *Vacuum Test*—Fill the assembly with air only. Apply a vacuum of 74 kPa (22 in. Hg). Close the valve and remove the vacuum line. Allow the assembly to stand for 10 min to check for leaks before testing. The internal pressure shall not change more than 3 kPa (1 in. Hg). Perform the test required, noting the internal pressure after the test condition is attained and again 10 min later. The internal pressure shall not change more than 17 kPa (5 in. Hg) during this second 10-min period or it constitutes a failure.

8. Retest and Rejection

8.1 If the results of any test(s) do not meet the requirements of this specification, the test(s) shall be conducted again only by agreement between the purchaser and the seller. Under such agreement, minimum requirements shall not be lowered, nor tests omitted, substituted, changed, or modified, nor shall specification limits be changed. If upon retest, failure occurs, the quantity of product represented by the test(s) does not meet the requirements of this specification.

9. Keywords

9.1 compression-type; elastomeric; joints; push-on joints; seals

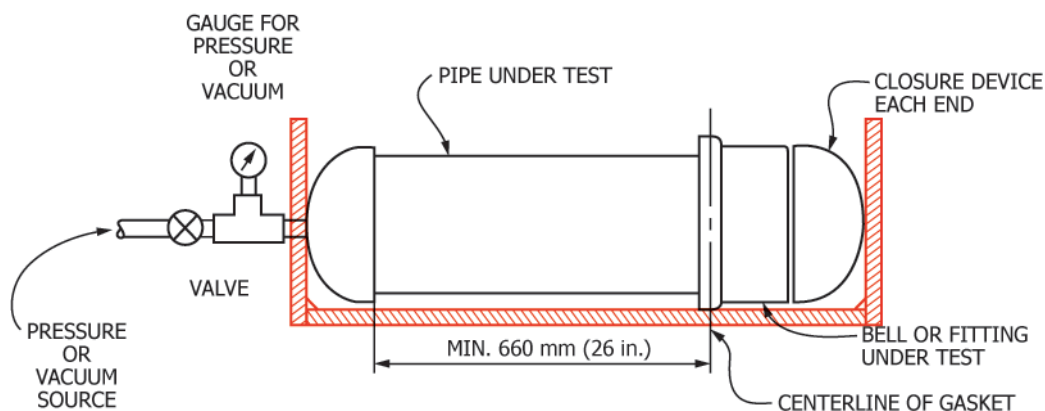

FIG. 1 Test Specimen