



Designation: ~~F2961~~—~~15~~ F2961 – 22

Standard Test Method for Characterizing Gripping Performance of Gloves Using a Torque Meter¹

This standard is issued under the fixed designation F2961; the number immediately following the designation indicates the year of original adoption or, in the case of revision, the year of last revision. A number in parentheses indicates the year of last reappraisal. A superscript epsilon (ϵ) indicates an editorial change since the last revision or reappraisal.

1. Scope

1.1 This test method is used for evaluating how gloves affect an individual wearer's ability to grip onto a hard surface object.

1.1.1 This test method establishes procedures for measuring the maximum torque that can be attained by an individual's bare hand as compared to the maximum torque that is attained by the same individual wearing a glove. The torque is applied to a ~~vertically-mounted~~ vertically mounted pole attached to a torque meter.

1.2 This test method is suitable for evaluating gloves and other forms of hand protection that require the wearer to maintain a secure hold on objects.

1.3 This test method does not address all effects of wearing gloves on hand functions. Other test methods include those for evaluating the effect of wearing gloves on dexterity, tactility, and other aspects of functional performance.

1.4 It is the responsibility of the test laboratory to obtain the necessary and appropriate approval(s) required by their institution for conducting tests using human subjects.

1.5 The values stated in SI units are to be regarded as standard. No other units of measurement are included in this standard.

1.6 *This standard does not purport to address all of the safety concerns, if any, associated with its use. It is the responsibility of the user of this standard to establish appropriate ~~safety~~ safety, health, and health ~~environmental~~ practices and determine the applicability of regulatory limitations prior to use.*

1.7 *This international standard was developed in accordance with internationally recognized principles on standardization established in the Decision on Principles for the Development of International Standards, Guides and Recommendations issued by the World Trade Organization Technical Barriers to Trade (TBT) Committee.*

2. Referenced Documents

2.1 ASTM Standards:²

~~D1776~~ D1776/D1776M Practice for Conditioning and Testing Textiles

E177 Practice for Use of the Terms Precision and Bias in ASTM Test Methods

E691 Practice for Conducting an Interlaboratory Study to Determine the Precision of a Test Method

¹ This test method is under the jurisdiction of ASTM Committee F23 on Personal Protective Clothing and Equipment and is the direct responsibility of Subcommittee F23.60 on Human Factors.

Current edition approved Feb. 1, 2015Feb. 1, 2022. Published ~~March 2015~~March 2022. Originally approved in 2014. Last previous edition approved in ~~2014~~2015 as F2961—14:F2961 – 15. DOI: ~~10.1520/F2961-15~~10.1520/F2961-22.

² For referenced ASTM standards, visit the ASTM website, www.astm.org, or contact ASTM Customer Service at service@astm.org. For *Annual Book of ASTM Standards* volume information, refer to the standard's Document Summary page on the ASTM website.

F1494 Terminology Relating to Protective Clothing

2.2 *NFPA Standards:*³

NFPA 1971 Standard on Protective Ensembles for Structural Fire Fighting and Proximity Fire Fighting

3. Terminology

3.1 For definitions of other protective clothing-related terms used in this test method, refer to Terminology **F1494**.

4. Summary of Test Method

4.1 The maximum torque applied to a vertically oriented cylindrical rod is measured without gloves and then later while wearing gloves. The bare hand maximum torque is compared to the gloved hand maximum torque in terms of a percentage. This percentage is useful in determining if a glove enhances or decreases an individual's ability to grip a hard object.

5. Significance and Use

5.1 This test method is intended to provide a quantitative measurement of wearing gloves on an individual's ability to grip a solid object and twist in a defined direction. The gripping performance may be different if twisted in the opposing direction or if pushing or pulling on a solid object while gripping.

5.2 This method was originally developed to help understand how materials and construction of firefighting gloves affected grip. Methods available at the time showed very little statistical difference between a wide range of gloves, including many NFPA 1971 compliant firefighting gloves and also non-compliant gloves used in other applications. This method was shown to have less subject-to-subject variability and a greater range of measured grip than previous tests.⁴

5.3 It is possible to apply this test method to other types of gloves, other than structural firefighting protective gloves. Evaluate the relevance of this test method by examining the particular application of the gloves for end user gripping capability. In addition, understand how this test method ranks gloves in comparison with end user perceptions.

5.4 This test method does not discriminate all glove effects on wearer hand function, nor does it apply to all glove types and applications. Consider additional evaluations or tests representative of the glove use applications performed to determine the overall impact of gloves on wearer hand functions.

6. Apparatus

6.1 *Testing Apparatus*—The device used to characterize the gripping performance of gloves consists of a torque meter with adjustable rod holder and a smooth acrylic cylindrical rod (**Fig. 1**). The rod is secured tightly in the adjustable rod holder attached to the torque meter.

6.2 Use a torque meter capable of meeting the following requirements:

6.2.1 Measuring 0 to 10.0 ± 0.5 N·m (88.5 ± 4.5 lb-in.).

6.2.1.1 A torque meter with a higher measuring range is allowed provided it still has an accuracy of ±0.5 N·m (±4.5 lb-in.).

6.2.2 Able to be fastened in place or heavy enough to be immobile during testing.

6.2.3 Able to measure torque in either a clockwise or counter-clockwise direction.

6.2.4 Fitting with an adjustable rod holder fixed to the upper surface of the meter.

6.2.4.1 The rod holder has four metal pins protruding upwards from the surface. Use 10 mm diameter pins that protrude 30 mm from the surface of the holder.

³ Available from National Fire Protection Association (NFPA), 1 Batterymarch Park, Quincy, MA 02169-7471, <http://www.nfpa.org>.

⁴ Ross, Barker, Watkins, and Deaton, "Methods for Measuring the Grip Performance of Structural Firefighting Gloves," *Performance of Protective Clothing and Equipment: Emerging Issues and Technologies*, ASTM STP 1544, Vol 9, A. Shepherd Ed., ASTM International, West Conshohocken, PA, 2012.



FIG. 1 Acrylic Rod Attached to a Torque Meter

(1) Cover the metal pins with a rubber material that is between 2.5 and 3.0 mm thick.

6.3 Use transparent cast acrylic rod meeting the following requirements:

6.4 Measures 600 mm (24 in.) in length and has a diameter of 41.5 mm (1.625 in.).

6.4.1 Has a surface roughness value of $0.10 \pm 0.05 \mu\text{m}$ ($4 \pm 2 \mu\text{in.}$) and is free of visual scratches and blemishes.

6.4.2 Use an acrylic rod with four grooves cut into the bottom of the rod. Grooves should match the size of the pins with rubber covering.

6.4.2.1 Fig. 2 shows an example of a rod cut with grooves at the bottom.

7. Sampling, Test Specimens, and Test Units

7.1 Use a minimum of three glove specimens for testing each model or type of glove.

7.1.1 Use right-handed glove specimens for right-hand dominant test subjects and left-handed glove specimens for left-hand dominant test subjects.

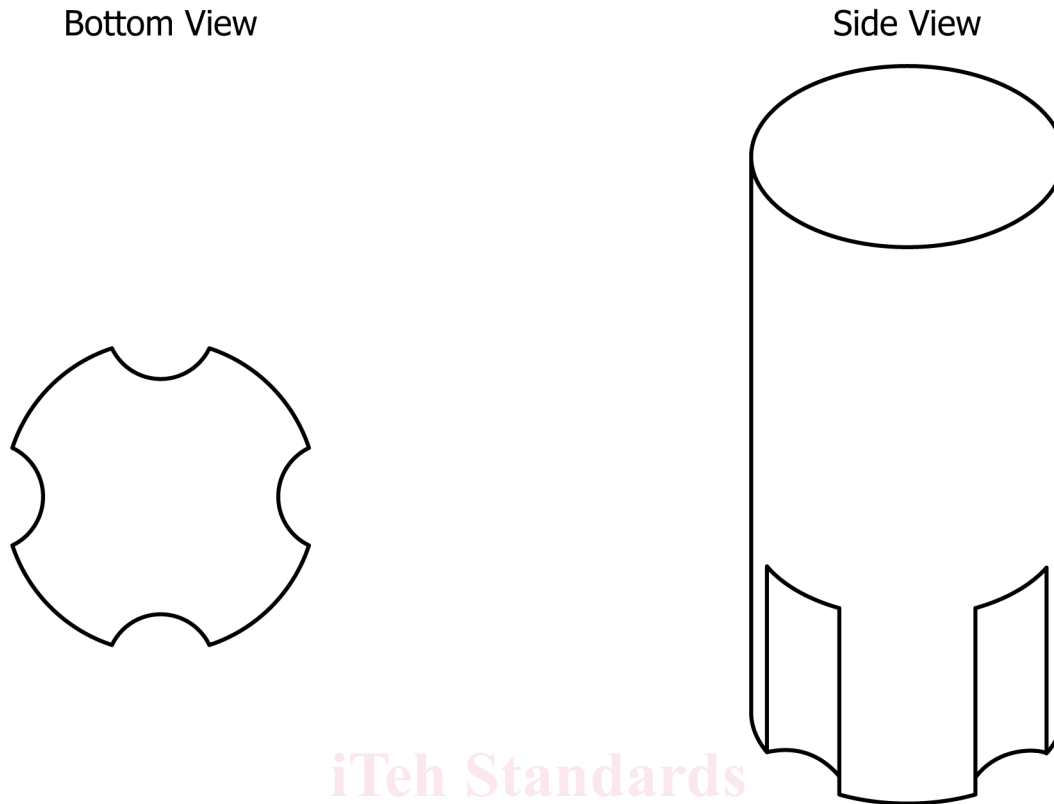

FIG. 2 Diagram of Rod Cut with Grooves at the Bottom

7.1.2 Each glove specimen shall be tested by a different human subject.

7.2 Each glove specimen shall be tested in a new, ~~as-distributed,~~ as-distributed condition.

7.2.1 Do not use glove specimens that are treated, broken-in, or conditioned in any manner other than specified in this test method prior to their evaluation unless otherwise specified.

8. Conditioning

8.1 Condition all glove specimens at a temperature of $21 \pm 3^{\circ}\text{C}$ ($70 \pm 5^{\circ}\text{F}$), and a relative humidity of $65 \pm 5\%$, until equilibrium is ~~reached,~~ reached as determined in accordance with Practice ~~D1776~~ D1776/D1776M, or for at least 24 h.

9. Procedure

9.1 Use a minimum of three test subjects with similar hand sizes.

9.1.1 Only use test subjects that obtain a bare hand average maximum torque applied value T_B greater than 4.5 N·m but less than ~~9.0 N·m,~~ 1.0 N·m below the maximum measurement capacity of the torque meter.

9.1.2 Fit the dominant hand of each test subject with a new glove, appropriately sized, in accordance with the manufacturer's recommendations for the selection and fit of available glove sizes.

9.1.2.1 For test subjects that are ambidextrous, subjects self-select which hand they will consider as dominant for the purpose of the test. This selected hand shall be used for both bare and gloved hand tests.

9.2 Conduct the test without the test subject's knowledge of the torque applied, that is, the test subject shall not be able to observe the reading from the torque meter or learn of the applied torque during any attempt to twist the rod.

~~9.3 No more than five different glove specimens shall be tested by the same test subject.~~ Test subject will go through no more than four testing cycles on the same day to reduce hand fatigue. A testing cycle consists of five consecutive bare hand repetitions, followed by a mandatory 5 min rest, followed by five consecutive gloved hand repetitions of a single glove specimen.

9.4 If conducting more than one testing cycle, test subjects must wait 15 min before conducting the next cycle of testing.

~~9.5 Conduct a bare hand torque measurement using a subject's dominant hand at the beginning of a testing cycle. A testing cycle consists of a bare hand measurements followed by gloved hand measurements.~~

~~9.4.1 If conducting more than one testing cycle subjects must wait 15 minutes before conducting the next cycle of testing. In addition, the glove specimens should be tested in a random order.~~

9.5.1 Set the torque meter to read a counter-clockwise torque for ~~right-handed~~ right-hand dominant test subjects. Set the torque meter to read a clockwise torque for left-hand dominant test subjects.

9.5.2 Test subjects stand such that they grab the acrylic rod with the elbow bent at a right angle and the upper arm against the side of the body.

9.5.2.1 Adjust the height of the test apparatus to provide the body and arm orientation described in [9.4.39.5.2](#).

9.5.2.2 The subject shall stand with feet parallel, facing the testing apparatus, and shoulder width apart.

9.5.2.3 The subject shall place the non-dominant arm at the body's side during testing.

9.5.2.4 In the correct position, the engaged arm will be parallel to the upright body from the shoulder to the elbow and perpendicular to the ventral plane of the body from the elbow to the wrist. An example can be seen in [Fig. 3](#).

9.5.3 With the bare hand firmly in grasp of the rod, each subject will make five successive attempts to twist the rod. Each attempt counts as a repetition.

9.5.3.1 Each repetition shall last no longer than 5 s and each successive repetition shall occur within ~~one minute~~ 1 min of the previous repetition.

9.5.3.2 The test subject's rotation during the repetition shall be in the wrist rather than in the shoulder. An example of how the wrist looks before and after the twisting action can be seen in [Figs. 4 and 5](#).

9.5.3.3 Record the maximum torque applied after each repetition.

9.5.3.4 Calculate the average maximum torque applied with the bare hand over the five attempts and identify it as T_B .

9.6 Allow a minimum of 5 min to pass after the last bare hand repetition to move to glove specimen testing.

~~9.7 Use the same hand for glove specimen testing.~~ Test subject dons glove specimen on the same hand as used for the bare handed bare-handed tests.

~~9.7.1 Test subjects don glove specimen and~~ Repeat testing position as outlined in [9.5](#) stand such that they grab the acrylic rod with the elbow bent at a right angle and the upper arm against the side of the body.

~~9.5.1.1 Adjust the height of the test apparatus to provide the body and arm orientation as described in [9.5.1](#).~~

~~9.5.1.2 The subject shall stand with feet parallel, facing the testing apparatus, and shoulder width apart.~~

~~9.5.1.3 The subject shall place the non-dominant arm at the body's side during testing.~~