



**SLOVENSKI STANDARD**  
**SIST EN 300 833 V1.3.1:2003**  
**01-december-2003**

---

: ]\_gb]fUX]g\_]g]ghYa ]E'5 bhYbYhjdUhc \_U!hc \_UE'5 bhYbYnUZ]\_gbYfUX]g\_]g]ghYa YhjdUhc \_U!hc \_Už\_]XYi Yc'j ZY\_j Yb bYa dUgi cX' ; <nXc \*\$; <n

Fixed Radio Systems; Point-to-point Antennas; Antennas for point-to-point fixed radio systems operating in the frequency band 3 GHz to 60 GHz

**iteh STANDARD PREVIEW**  
**(standards.iteh.ai)**

Ta slovenski standard je istoveten z: **EN 300 833 Version 1.3.1**  
<https://standards.iteh.ai/catalog/standards/sist/41b048e-001e-4360-bd85-d3b5df6071a2/sist-en-300-833-v1-3-1-2003>

**ICS:**

33.060.30	Radiorelejni in fiksni satelitski komunikacijski sistemi	Radio relay and fixed satellite communications systems
33.120.40	Antene	Aerials

**SIST EN 300 833 V1.3.1:2003**                      **en**

**iTeh STANDARD PREVIEW**  
**(standards.iteh.ai)**

[SIST EN 300 833 V1.3.1:2003](https://standards.iteh.ai/catalog/standards/sist/f4fb048e-001e-4360-bd85-d3b5dfa071a2/sist-en-300-833-v1-3-1-2003)

<https://standards.iteh.ai/catalog/standards/sist/f4fb048e-001e-4360-bd85-d3b5dfa071a2/sist-en-300-833-v1-3-1-2003>

# ETSI EN 300 833 V1.3.1 (2001-08)

---

*European Standard (Telecommunications series)*

**Fixed Radio Systems;  
Point-to-point Antennas;  
Antennas for point-to-point fixed radio systems  
operating in the frequency band 3 GHz to 60 GHz**

---

**iTeh STANDARD PREVIEW  
(standards.iteh.ai)**

[SIST EN 300 833 V1.3.1:2003](https://standards.iteh.ai/catalog/standards/sist/f4fb048e-001e-4360-bd85-d3b5dfa071a2/sist-en-300-833-v1-3-1-2003)

<https://standards.iteh.ai/catalog/standards/sist/f4fb048e-001e-4360-bd85-d3b5dfa071a2/sist-en-300-833-v1-3-1-2003>



---

**Reference**

REN/TM-04122

---

**Keywords**antenna, DRRS, point-to-point, radio,  
transmission**ETSI**650 Route des Lucioles  
F-06921 Sophia Antipolis Cedex - FRANCE

Tel.: +33 4 92 94 42 00 Fax: +33 4 93 65 47 16

Siret N° 348 623 562 00017 - NAF 742 C  
Association à but non lucratif enregistrée à la  
Sous-Préfecture de Grasse (06) N° 7803/88

**iTeh STANDARD PREVIEW**  
**(standards.iteh.ai)**

SIST EN 300 833 V1.3.1:2003

<https://standards.iteh.ai/catalog/standards/sist/f4fb048e-001e-4360-bd85-d3b5dfa071a2/sist-en-300-833-v1-3-1-2003>

---

**Important notice**

Individual copies of the present document can be downloaded from:

<http://www.etsi.org>

The present document may be made available in more than one electronic version or in print. In any case of existing or perceived difference in contents between such versions, the reference version is the Portable Document Format (PDF). In case of dispute, the reference shall be the printing on ETSI printers of the PDF version kept on a specific network drive within ETSI Secretariat.

Users of the present document should be aware that the document may be subject to revision or change of status. Information on the current status of this and other ETSI documents is available at <http://www.etsi.org/tb/status/>

If you find errors in the present document, send your comment to:  
[editor@etsi.fr](mailto:editor@etsi.fr)

---

**Copyright Notification**

No part may be reproduced except as authorized by written permission.  
The copyright and the foregoing restriction extend to reproduction in all media.

© European Telecommunications Standards Institute 2001.  
All rights reserved.

# Contents

Intellectual Property Rights .....	4
Foreword .....	4
Introduction .....	4
1 Scope .....	5
2 References .....	5
3 Definitions, symbols and abbreviations .....	5
3.1 Definitions .....	5
3.2 Symbols .....	6
3.3 Abbreviations .....	6
4 Frequency ranges .....	7
5 Classification of antennas .....	7
6 Electrical characteristics .....	8
6.1 Radiation Pattern Envelope (RPE) .....	8
6.2 Cross-Polar Discrimination (XPD) .....	28
6.3 Antenna gain .....	29
7 Conformance tests .....	29
<b>Annex A (informative): Additional information .....</b>	<b>30</b>
A.1 Mechanical characteristics .....	30
A.1.1 Environmental characteristics .....	30
A.1.2 Antenna stability .....	30
A.2 Antenna input connectors .....	30
A.3 Return loss at the input ports .....	31
A.4 Inter-port isolation .....	31
A.5 Antenna labelling .....	31
<b>Annex B (informative): Bibliography .....</b>	<b>32</b>
History .....	33

**STANDARD PREVIEW**

(standards.iteh.ai)

SIST EN 300 833 V1.3.1:2003

<https://standards.iteh.ai/catalog/standards/sist/f4fb048e-001e-4360-bd85-d3b5dfa071a2/sist-en-300-833-v1-3-1-2003>

---

## Intellectual Property Rights

IPRs essential or potentially essential to the present document may have been declared to ETSI. The information pertaining to these essential IPRs, if any, is publicly available for **ETSI members and non-members**, and can be found in ETSI SR 000 314: "*Intellectual Property Rights (IPRs); Essential, or potentially Essential, IPRs notified to ETSI in respect of ETSI standards*", which is available from the ETSI Secretariat. Latest updates are available on the ETSI Web server (<http://www.etsi.org/ipr>).

Pursuant to the ETSI IPR Policy, no investigation, including IPR searches, has been carried out by ETSI. No guarantee can be given as to the existence of other IPRs not referenced in ETSI SR 000 314 (or the updates on the ETSI Web server) which are, or may be, or may become, essential to the present document.

---

## Foreword

This European Standard (Telecommunications series) has been produced by ETSI Technical Committee Transmission and Multiplexing (TM).

---

## Introduction

The purpose of the present document is to define only those antenna parameters necessary to ensure optimum frequency co-ordination between communication services in the frequency range 3 GHz to 60 GHz. Additional parameters appropriate to system implementation may be subject to agreement between the equipment purchaser and supplier. Further guidance is provided in annex A.

(standards.iteh.ai)

National transposition dates	
Date of adoption of this EN:	27 July 2001
Date of latest announcement of this EN (doa):	31 October 2001
Date of latest publication of new National Standard or endorsement of this EN (dop/e):	30 April 2002
Date of withdrawal of any conflicting National Standard (dow):	30 April 2002

---

# 1 Scope

The present document addresses the minimum requirements for single main beam, linear polarization, directional antennas to be adopted in conjunction with Point-to-Point (P-P) systems operating in the frequency range 3 GHz to 60 GHz.

Single polarization antennas, dual polarization antennas, dual band/single polarized antennas and dual band/dual polarization antennas are considered.

A regulatory authority may impose tighter requirements than the minimum values given in the present document, in order to maximize the use of the scarce spectrum resources.

---

# 2 References

The following documents contain provisions which, through reference in this text, constitute provisions of the present document.

- References are either specific (identified by date of publication and/or edition number or version number) or non-specific.
- For a specific reference, subsequent revisions do not apply.
- For a non-specific reference, the latest version applies.

- [1] WRC 1995: "Final Acts of the World Radiocommunication Conference (WRC-95)".
- [2] ITU-R Recommendation R.746-2: "Radio-frequency channel arrangements for radio-relay systems".
- [3] IEC 835-2-2 (1994): "Methods of measurement for equipment used in digital microwave transmission systems; Part 2: Measurements on terrestrial radio-relay systems - Section 2: Antenna".
- [4] ETSI EN 301 126-1: "Fixed Radio Systems; Conformance testing; Part 1: Point-to-point equipment - Definitions, general requirements and test procedures".

---

# 3 Definitions, symbols and abbreviations

## 3.1 Definitions

For the purposes of the present document, the following terms and definitions apply.

**antenna inter port isolation:** ratio in dB of the power level applied to one port of a multi-port antenna to the power level received in any other port of the same antenna as function of frequency

**antennas:** part of the transmitting or receiving system that is designed to radiate and/or receive electromagnetic waves

**co-polar pattern:** diagram representing the radiation pattern of the antenna under test when the reference antenna is similarly polarized, scaled in dBi or dB relative to the measured antenna gain

**cross-polar discrimination:** difference in dB between the co-polarized main beam gain and the cross-polarized signal measured within a defined region

**cross-polar pattern:** diagram representing the radiation pattern of the antenna under test when the reference antenna is orthogonally polarized, scaled in dBi or dB relative to the measured antenna gain

**frequency band:** frequency band of an antenna is the band of frequencies over which the performance characteristics of the antenna are within specified limits

**gain:** ratio of the radiation intensity, in the main beam axis to the radiation intensity that would be obtained if the power accepted by the antenna was radiated isotropically. Value measured in dBi.

**half power beamwidth:** angle, relative to the main beam axis, between the two directions at which the measured co-polar pattern is 3 dB below the value on the main beam axis

**input port(s):** flange(s) or connector(s) through which access to the antenna system is provided. This is shown in the following figure 1 at points D and D'.

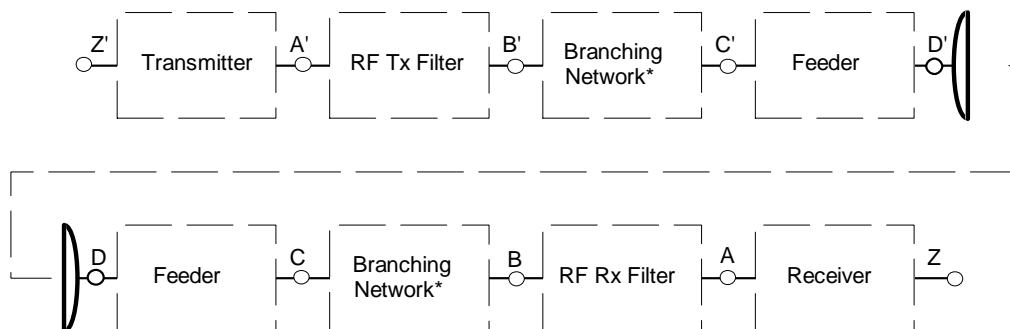

NOTE: The points shown above are reference points only; points B, C and D, B', C' and D' may coincide.

**Figure 1: System block diagram**

**isotropic radiator:** hypothetical, lossless antenna having equal radiation intensity in all directions

**main beam axis:** direction for which the radiation pattern intensity is the maximum

**main beam:** radiation lobe containing the direction of maximum radiation

**radiation pattern envelope:** envelope below which the radiation pattern shall fit

**radiation pattern:** diagram relating power flux density at a constant distance from an antenna to direction relative to the antenna main beam axis

**radome:** cover of dielectric material, intended for protecting an antenna from the effects of the physical environment

## 3.2 Symbols

For the purposes of the present document, the following symbols apply:

dB	deciBel
dBi	deciBels relative to an isotropic radiator
GHz	GigaHertz

## 3.3 Abbreviations

For the purposes of the present document, the following abbreviations apply:

P-P	Point-to-Point
RPE	Radiation Pattern Envelope
VSWR	Voltage Standing Wave Ratio
WRC	World Radiocommunication Conference
XPD	Cross-Polar Discrimination



## 4 Frequency ranges

The present document applies to sub-bands within 3 GHz to 60 GHz frequency band. Fixed link frequency allocations are in accordance with the WRC 1995 [1] as given in ITU-R Recommendation F.746-2 [2] and other frequency plans.

For the purposes of the present document, the overall frequency range 3 GHz to 60 GHz is divided into six frequency ranges as follows:

- Range 1: 3 GHz - 14 GHz;
- Range 2: 14 GHz - 20 GHz;
- Range 3: 20 GHz - 24 GHz;
- Range 4: 24 GHz - 30 GHz;
- Range 5: 30 GHz - 47 GHz;
- Range 6: 47 GHz - 60 GHz.

## 5 Classification of antennas

With respect to antenna gain, two gain categories are applicable:

- Gain category 1: those antennas which require low gain for co-ordination purposes;
- Gain category 2: those antennas which require high gain for co-ordination purposes.

With respect to Radiation Pattern Envelope (RPE), four classes have been identified:

- Class 1: Those antennas required for use in networks where there is a low interference potential. Typical examples of a low interference potential might be:
  - antennas for use in radio networks where there is a low density deployment, and therefore, a low potential for inter- and intra-system interference, and where high capacity digital radio is proposed;
  - antennas for use in radio networks where there is a medium potential for inter- and intra-system interference, and where low capacity digital radio is proposed.
- Class 2: Those antennas required for use in networks where there is a high interference potential. Typical examples of a high interference potential might be:
  - antennas for use in radio networks where there is a medium potential for inter- and intra-system interference, and where high capacity digital radio is proposed;
  - antennas for use in radio networks where there is a high density deployment, and therefore, a high potential for inter- and intra-system interference, and where low capacity digital radio is proposed.
- Class 3: Those antennas required for use in networks where there is a very high interference potential. Typical examples of a very high interference potential might be:
  - antennas for use in radio networks where there is a high density deployment, and therefore, a high potential for inter- and intra-system interference, and where high capacity digital radio is proposed.
- Class 4: Those antennas required for use in networks where there is an extremely high interference potential. Typical examples of an extremely high interference potential might be:
  - antennas for use in radio networks where there is a very high density deployment, and therefore, a very high potential for inter- and intra-system interference, and where high capacity digital radio is proposed.

In frequency bands where spectrum congestion is likely to exist, the regulator may insist on the use of higher class antennas.

With respect to cross-Polar Discrimination (XPD), three XPD performance categories have been identified (refer to clause 6.2, table 1):

- XPD category 1: those antennas required to have standard cross-polar discrimination.
- XPD category 2: those antennas required to have high cross-polar discrimination.
- XPD category 3: those antennas required to have high cross-polar discrimination in extended angular region.

---

## 6 Electrical characteristics

The antenna manufacturer shall state, for each antenna type, the frequency band of operation and antenna gain at least at the frequency band edges and at mid-band. An antenna which employs a radome shall meet the requirements of the present document with the radome in place.

The antenna system shall radiate a linear (single or dual) polarized wave.

The method of measurement shall be in accordance to IEC 835-2-2 [3].

### 6.1 Radiation Pattern Envelope (RPE)

RPE(s) for each class are included, in order to present the maximum flexibility to administrations for optimized co-ordination.

The co-polar and cross-polar radiation pattern measured in the azimuth plane for both polarizations, shall not exceed the RPE(s) defined in the following list:

Range 1:

- Class 1: figure 2a);
- Class 2: figure 2b);
- Class 3: figure 2c);
- Class 4: figure 2d).

Range 2:

- Class 1: figure 3a);
- Class 2: figure 3b);
- Class 3: figure 3c).

Range 3:

- Class 1: figure 4a);
- Class 2: figure 4b);
- Class 3: figure 4c).

Range 4:

- Class 1: figure 5a);
- Class 2: figure 5b).

Range 5:

- Class 1: figure 6a);
- Class 2: figure 6b);

- Class 3: figure 6c);
- Class 4: figure 6d)

Range 6:

- Class 1: figure 7a);
- Class 2: figure 7b);
- Class 3: figure 7c), vertically polarized only.

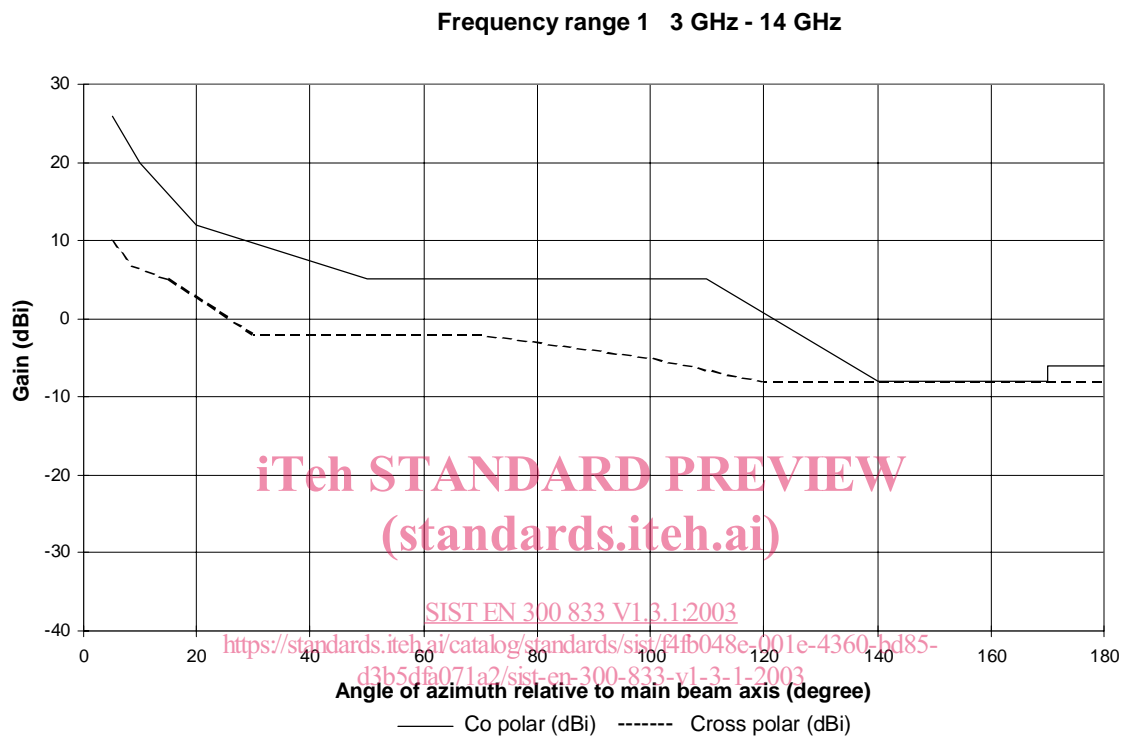

Angle (degrees)	Co-polar (dBi)	Angle (degrees)	Cross-polar (dBi)
5	26	5	10
10	20	8	7
20	12	15	5
50	5	30	-2
110	5	70	-2
140	-8	100	-5
170	-8	120	-8
170	-6	180	-8
180	-6		

Figure 2a): RPEs for class 1 antennas in the frequency range 1

## Frequency range 1 3 GHz - 14 GHz

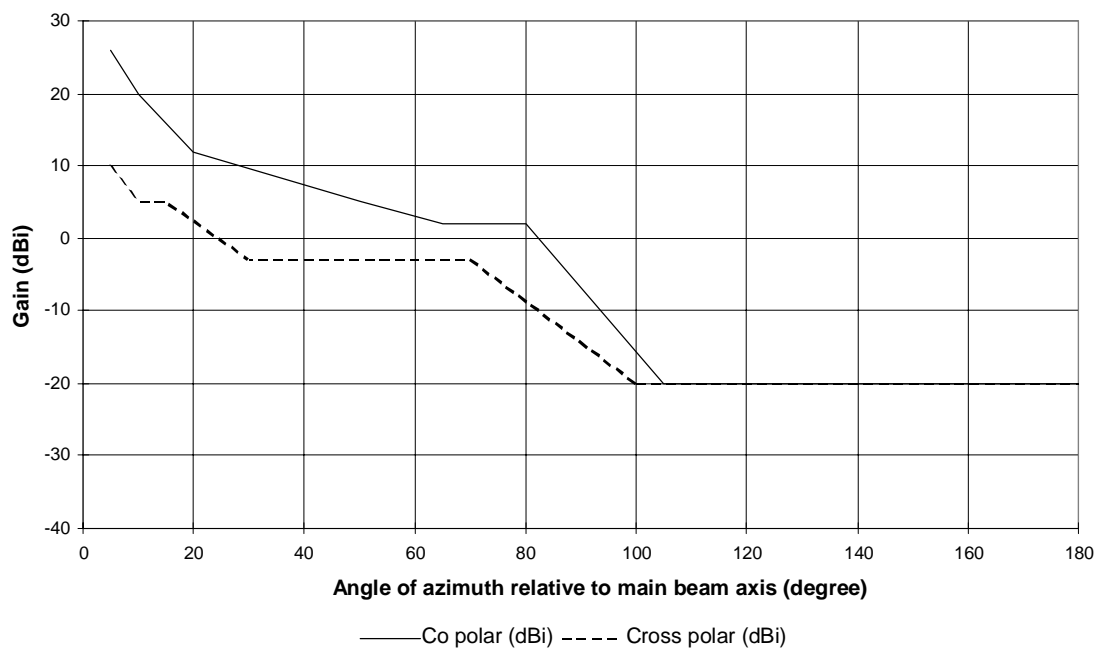

Angle (degrees)	Co-polar (dBi)	Angle (degrees)	Cross-polar (dBi)
5	26	5	10
10	20	10	5
20	12	15	5
50	5	30	-3
65	2	70	-3
80	2	100	-20
105	-20	180	-20
180	-20		

Figure 2b): RPEs for class 2 antennas in the frequency range 1