



Designation: **C1323–16** **C1323 – 22**

Standard Test Method for Ultimate Strength of Advanced Ceramics with Diametrically Compressed C-Ring Specimens at Ambient Temperature¹

This standard is issued under the fixed designation C1323; the number immediately following the designation indicates the year of original adoption or, in the case of revision, the year of last revision. A number in parentheses indicates the year of last reappraisal. A superscript epsilon (ϵ) indicates an editorial change since the last revision or reappraisal.

1. Scope

1.1 This test method covers the determination of ultimate strength under monotonic loading of advanced ceramics in tubular form at ambient temperatures. The ultimate strength as used in this test method refers to the strength obtained under monotonic compressive loading of C-ring specimens such as shown in Fig. 1, where monotonic refers to a continuous nonstop test rate with no reversals from test initiation to final fracture. This method permits a range of sizes and shapes since test specimens may be prepared from a variety of tubular structures. The method may be used with microminiature test specimens.

1.2 The values stated in SI units are to be regarded as standard. No other units of measurement are included in this standard.

1.2.1 Values expressed in this test method are in accordance with the International System of Units (SI) and **IEEE/ASTM SI 10**.

1.3 *This standard does not purport to address all of the safety concerns, if any, associated with its use. It is the responsibility of the user of this standard to establish appropriate safety, health, and environmental practices and determine the applicability of regulatory limitations prior to use.*

1.4 *This international standard was developed in accordance with internationally recognized principles on standardization established in the Decision on Principles for the Development of International Standards, Guides and Recommendations issued by the World Trade Organization Technical Barriers to Trade (TBT) Committee.*

2. Referenced Documents

2.1 ASTM Standards:²

- C1145 Terminology of Advanced Ceramics
- C1161 Test Method for Flexural Strength of Advanced Ceramics at Ambient Temperature
- C1239 Practice for Reporting Uniaxial Strength Data and Estimating Weibull Distribution Parameters for Advanced Ceramics
- C1322 Practice for Fractography and Characterization of Fracture Origins in Advanced Ceramics
- C1368 Test Method for Determination of Slow Crack Growth Parameters of Advanced Ceramics by Constant Stress Rate Strength Testing at Ambient Temperature
- C1683 Practice for Size Scaling of Tensile Strengths Using Weibull Statistics for Advanced Ceramics
- E4 Practices for Force Calibration and Verification of Testing Machines
- E6 Terminology Relating to Methods of Mechanical Testing
- E337 Test Method for Measuring Humidity with a Psychrometer (the Measurement of Wet- and Dry-Bulb Temperatures)

¹ This test method is under the jurisdiction of ASTM Committee C28 on Advanced Ceramics and is the direct responsibility of Subcommittee C28.04 on Applications. Current edition approved Jan. 15, 2016/March 15, 2022. Published February 2016/March 2022. Originally approved in 1996. Last previous edition approved in 2010/2016 as C1323–10/C1323–16. DOI: 10.1520/C1323-16.10.1520/C1323-22.

² For referenced ASTM standards, visit the ASTM website, www.astm.org, or contact ASTM Customer Service at service@astm.org. For Annual Book of ASTM Standards volume information, refer to the standard's Document Summary page on the ASTM website.

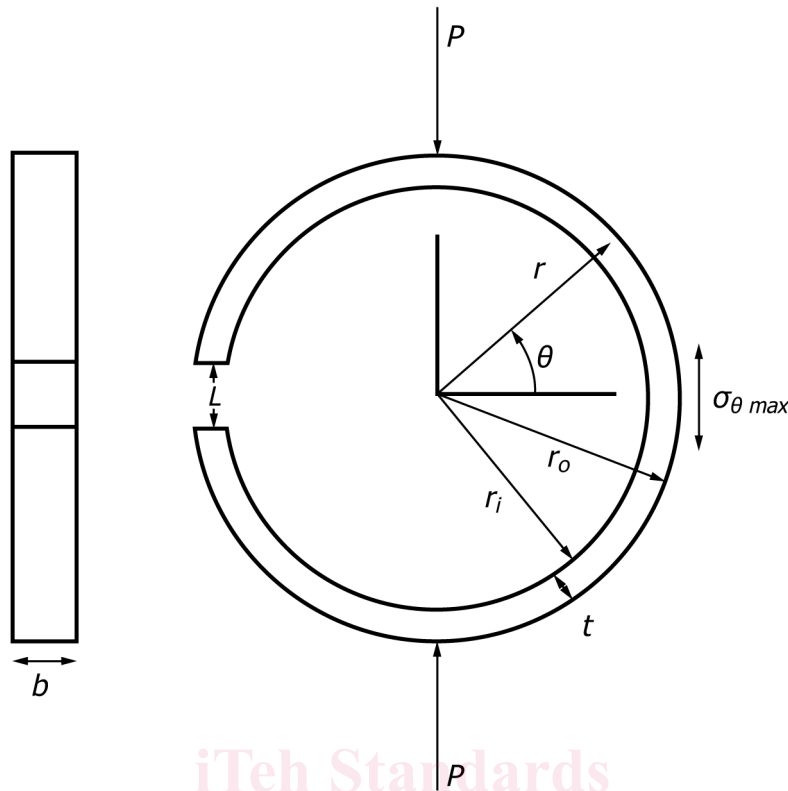

FIG. 1 —C-Ring-C-Ring Test Geometry with Defining Geometry and Reference Angle (θ) for the Point of Fracture Initiation on the Circumference

IEEE/ASTM SI 10 American National Standard for Use of the International System of Units (SI): The Modern Metric System Metric Practice

3. Terminology

3.1 Definitions: [ards.iteh.ai/catalog/standards/sist/cecdc3b8-d52d-44ce0-97cb-ef793e9082ce/astm-c1323-22](https://standards.iteh.ai/catalog/standards/sist/cecdc3b8-d52d-44ce0-97cb-ef793e9082ce/astm-c1323-22)

3.1.1 *advanced ceramic*—an engineered, high-performance, predominately nonmetallic, a highly engineered, high performance, predominately non-metallic, inorganic, ceramic material having specific functional qualities: attributes. (C1145)

3.1.2 *breaking force*—the force at which fracture occurs. (E6)

3.1.3 *C-ring*—circular test specimen geometry with the mid-section (slot) removed to allow bending displacement (compression or tension). (E6)

3.1.4 *flexural strength*—a measure of the ultimate strength of a specified beam in bending.

3.1.5 *modulus of elasticity*—the ratio of stress to corresponding strain below the proportional limit. (E6)

3.1.6 *slow crack growth*—subcritical crack growth (extension) which may result from, but is not restricted to, such mechanisms as environmentally assisted stress corrosion or diffusive crack growth.

4. Significance and Use

4.1 This test method may be used for material development, material comparison, quality assurance, and characterization. Extreme care should be exercised when generating design data.

4.2 For a C-ring under diametral compression, the maximum tensile stress occurs at the outer surface. Hence, the C-ring specimen

loaded in compression will predominately evaluate the strength distribution and flaw population(s) on the external surface of a tubular component. component in the hoop direction. Accordingly, the condition of the inner surface may be of lesser consequence in specimen preparation and testing.

NOTE 1—A C-ring in tension or an O-ring in compression may be used to evaluate the internal surface.

4.2.1 The flexure stress is computed based on simple ~~curved-beam~~ curved beam theory (~~11-5, 2, 3, 4, 5~~).³ It is assumed that the material is isotropic and homogeneous, the moduli of elasticity are identical in compression or tension, and the material is linearly elastic. These homogeneity and isotropy assumptions preclude the use of this standard for continuous fiber reinforced composites. Average grain size(s) should be no greater than one fiftieth ($1/50$) of the C-ring thickness. The ~~curved-beam~~ curved beam stress solution from engineering mechanics is in good agreement (within 2 %) with an elasticity solution as discussed in (6) for the test specimen geometries recommended for this standard. The curved beam stress equations are simple and straightforward, and therefore it is relatively easy to integrate the equations for calculations for effective area or effective volume for Weibull analyses as discussed in **Appendix X1**.

4.2.2 The simple curved beam and theory of elasticity stress solutions both are two-dimensional plane stress solutions. They do not account for stresses in the axial (parallel to b) direction, or variations in the circumferential (hoop, σ_θ) stresses through the width (b) of the test piece. The variations in the circumferential stresses increase with increases in width (b) and ring thickness (t). The variations can be substantial (>10 %) for test specimens with large b . The circumferential stresses peak at the outer edges. Therefore, the width (b) and thickness (t) of the specimens permitted in this test method are limited so that axial stresses are negligible (see Ref. (5)) and the variations of the circumferential stresses from the nominal simple curved beam theory stress calculations are typically less than 4 %. See ~~Ref:Refs.~~ (4) and (6) for more information on the variation of the circumferential stresses as a function of ring thickness (t) and ring width (b).

4.2.3 The test piece outer rim corners are vulnerable to edge damage, another reason to minimize the differences in the circumferential stresses across the ring outer surface.

4.2.4 Other geometry ~~C-ring~~ C-ring test specimens may be tested, but comprehensive finite element analyses shall be performed to obtain accurate stress distributions. If strengths are to be scaled (converted) to strengths of other sizes or geometries, then Weibull effective volumes or areas shall be computed using the results of the finite element analyses.

4.3 Because advanced ceramics exhibiting brittle behavior generally fracture catastrophically from a single dominant flaw for a particular tensile stress field in quasi-static loading, the surface area and volume of material subjected to tensile stresses is a significant factor in determining the ultimate strength. Moreover, because of the statistical distribution of the flaw population(s) in advanced ceramics exhibiting brittle behavior, a sufficient number of specimens at each testing condition is required for statistical analysis and design. This test method provides guidelines for the number of specimens that should be tested for these purposes (see 8.4).

4.4 Because of a multitude of factors related to materials processing and component fabrication, the results of C-ring tests from a particular material or selected portions of a part, or both, may not necessarily represent the strength and deformation properties of the full-size end product or its in-service behavior.

4.5 The ultimate strength of a ceramic material may be influenced by slow crack growth or stress corrosion, or both, and is ~~therefore, therefore~~ sensitive to the testing mode, testing rate, or environmental influences, or a combination thereof. Testing at sufficiently rapid rates as outlined in this test method may minimize the consequences of subcritical (slow) crack growth or stress corrosion.

4.6 The flexural behavior and strength of an advanced monolithic ceramic are dependent on the material's inherent resistance to fracture, the presence of flaws, or damage accumulation processes, or a combination thereof. Analysis of fracture surfaces and fractography, though beyond the scope of this test method, is highly recommended (further guidance may be obtained from Practice **C1322** and Ref (7)).

5. Interferences

5.1 Test environment (vacuum, inert gas, ambient air, ~~etc., etc.~~), including moisture content (that is, relative ~~humidity~~ humidity),

³ The boldface numbers in parentheses refer to a list of references at the end of this test method.

may have an influence on the measured ultimate strength. In particular, the behavior of materials susceptible to slow ~~crack-growth~~ crack growth fracture will be strongly influenced by test environment and testing rate. Testing to evaluate the maximum inert strength (strength potential) of a material shall therefore be conducted in inert environments or at sufficiently rapid testing rates, or both, so as to minimize slow ~~crack-growth~~ crack growth effects. Conversely, testing can be conducted in environments and testing modes and rates representative of service conditions to evaluate material performance under use conditions. When testing in uncontrolled ambient air for the purpose of evaluating maximum inert strength (strength potential), relative humidity and temperature must be monitored and reported. Testing at humidity levels >65 % RH is not recommended and any deviations from this recommendation must be reported.

5.2 C-ring specimens are useful for the determination of ultimate strength of the outer diameter of tubular components in the as-received/as-used condition without surface preparations that may distort the strength controlling flaw population(s). Nonetheless, machining damage introduced during specimen preparation can be either a random interfering factor in the determination of the maximum inert strength (strength potential), or an inherent part of the strength characteristics being measured. Universal or standardized methods of surface/sample preparation do not exist. Hence, final machining steps may or may not negate machining damage introduced during the initial machining. Thus, specimen fabrication history may play an important role in the measured strength distributions and shall be reported.

5.3 Very small C-ring test specimens made by ~~micro-fabrication~~ microfabrication methods may also be tested. These typically are tested in the as-fabricated state and do not require any machining preparation. Chamfers or edge bevels may not be necessary. Dimensional nonuniformities (~~e.g.,~~ for example, through-thickness tapers or fabrication template artifacts) may alter the stress state and create experimental errors.

6. Apparatus

6.1 *Loading*—Specimens shall be loaded in any suitable testing machine provided that uniform rates of direct loading can be maintained. The system used to monitor the loading shall be free from any initial lags and will have the capacity to record the maximum force applied to the C-ring specimen during the test. Testing machine accuracy shall be within 1.0 % in accordance with Practices E4.

6.1.1 This test method permits the use of either fixed loading rams or, when necessary (see 9.3), a self-adjusting fixture. A self-adjusting fixture may include a universal joint or spherically seated platen used in conjunction with the upper loading ram. Such an articulating fixture may be necessary to ensure even line loading from front to back across the top of a C-ring test specimen. Articulation from side to side is not required since a flat loading platen contacts the C-ring at its top on its centerline. When fixed loading rams are used, they shall be aligned so that the platen surfaces which come into contact with the specimens are parallel to within 0.015 mm over the width of the test piece. Alignment of the testing system must be verified at a minimum at the beginning and at the end of a test series. An additional verification of alignment is recommended, although not required, at the middle of the test series.

NOTE 2—A test series is interpreted to mean a discrete group of tests on individual specimens conducted within a discrete period of time on a particular material configuration, test specimen geometry, test conditions, or other uniquely definable qualifier. For example, a test series may be composed of one material comprising ten specimens of one geometry tested at a fixed rate in strain control to final fracture in ambient ~~air~~ air.

6.1.2 Materials such as foil or thin rubber sheet shall be used between the loading rams and the specimen for ambient temperature tests to reduce the effects of friction and to redistribute the force. Aluminum oxide (alumina) felt or other high-temperature “cloth” with a high-temperature capability may also be used at ambient or elevated temperature. The use of a material with a high-temperature capability is recommended to ensure consistency with elevated temperature tests (if planned), provided the high-temperature “cloth” is chemically compatible with the specimen at all testing temperatures.

6.2 The fixture used during the tests shall be stiffer than the specimen to ensure that a majority of the crosshead travel (at least 80 %) is imposed on the C-ring specimen.

6.3 *Data Acquisition*—~~At the minimum, an autographic record of applied force shall be obtained. Either digital acquisition systems or analog chart recorders or digital data acquisition systems can may be used for this purpose. Ideally, an analog chart recorder or plotter shall be used in conjunction with a digital data acquisition system to provide an immediate record of the test as a supplement to the digital record. Recording devices shall purpose, although a digital record is recommended for ease of later data analysis. Recording devices must be accurate to $0.1\% \pm 1\%$ of full scale and shall have a minimum data acquisition rate of 10 Hz, with a response of 50 Hz deemed more than sufficient.~~

7. Hazards

7.1 During the conduct of this test, the possibility of flying fragments of broken test material may be high. Means for containment and retention of these fragments for safety, later fractographic reconstruction, and analysis is highly recommended. It is advisable to buffer the fragments so that they do not suffer needless secondary impact fractures. Tape applied to the inside diameter may aid in specimen fragment retention.

8. Specimen

8.1 *General*—The C-ring geometry is designed to evaluate the ultimate strength of advanced monolithic materials in tubular form in as-received or as-machined form. When possible, the specimen shall reflect the actual size of the component to minimize size scaling effects and to increase the likelihood that the specimen will have the same microstructure and flaw population(s) as the component. Hence, standard specimen dimensions or overall sizes cannot be recommended without compromising the original purpose of the test method. Instead, specimens shall be prepared from the stock used for the actual component when possible.

8.1.1 *Specimen Size*—The width of the test specimen, b , should be at least one, but no greater than two times the ring thickness, t :

$$1 \leq \left(\frac{b}{t}\right) = \left(\frac{b}{r_o - r_i}\right) \leq 2 \quad (1)$$

where the dimensional terms t (the ring thickness), b (the ring width), and r_o , the outer radius, and r_i , the inner radii are shown in Fig. 1. These limits are to ensure that essentially plane stress conditions exist (6, 8, 9) in the specimen; variations in the circumferential stresses through the width of the test specimen are minimized (4, 6); and axial stresses are minimal (5). If it is necessary to use wider test specimens (larger b) than this range, then consult paragraphs 4.2.2 – 4.2.4 4.3.2 to 4.3.4 for further guidance. The test specimen thickness, t , and thus the radii, shall be within the following range:

$$0.5 \leq \frac{r_i}{r_o} \leq 0.95 \quad (2)$$

or

$$0.05r_o \leq t \leq 0.5r_o \quad (3)$$

8.1.2 The parallelism tolerance for the two machined side faces of the C-ring specimen is 0.015 mm.

8.2 *Specimen Preparation*—Depending on the intended application of the ultimate strength data, use one of the following specimen preparation procedures. C-ring test specimens are very sensitive to outer surface and edge damage, so they must be prepared carefully (10, 11). The slot is usually prepared as the last step.

8.2.1 *As-Fabricated*—The external surface of the C-ring specimen shall simulate the surface conditions and processing route of an application where no machining is used. No additional machining specifications for these surfaces are relevant. The two flat side faces shall be machined from the tubular stock and lap finished with 15 μm media to remove any large machining defects. All edges shall then be either chamfered at 45° to a distance of 0.12 ± 0.05 mm or rounded to a radius of 0.15 ± 0.05 mm to avoid edge dominated failures.

NOTE 3—If the C-ring specimen has a nonuniform diameter, the edge chamfer or round tolerances stated in 8.2.1 may be relaxed; however, the edges shall still be chamfered or rounded. As-fabricated rings with nonuniform diameters may be difficult to prepare with uniform chamfers or edge bevels. Uneven or hand-prepared hand-prepared chamfers or rounded edges may lead to an inordinate number of fractures that initiate at the edges. A supplemental fine finishing step with a 600 grit wheel may be beneficial.

8.2.2 *Application-Matched Machining*—The C-ring specimen shall have the same surface preparation as that given to the component. When possible, the specimen shall also retain the original radii of the component provided the surface area and volume are sufficient to sample the inherent flaws of the material under study. All other side finishing specifications shall be the same as the as-fabricated specimens. Unless the process is proprietary, the report shall include all details about the stages of material removal, wheel grits, wheel bonding, and the material removal rates for each pass.

8.2.3 *Standard Procedure*—In instances where 8.2.1 through 8.2.2 are not appropriate, 8.2.3 shall apply. This procedure shall be viewed as a baseline; more stringent procedures may be necessary depending on the application(s).

NOTE 4—This procedure is similar to the ones specified in Test Method C1161.

8.2.3.1 All grinding or cutting shall be done with ample supply of appropriate filtered coolant to keep the workpiece and grinding wheel constantly flooded and particles flushed. Grinding must be done in at least two stages, ranging from coarse to a finer rate of material removal. All cutting can be done in one stage appropriate for the depth of cut. Unless the process is proprietary, all reports shall be specific about the stages of material removal, wheel grits, wheel bonding, amount of material removed per pass, and type of coolant used. Centerless or transverse grinding modes may be used on the outside diameter prior to slotting. Surface grinding is recommended for the two flat side faces, but the grinding directions on the two sides shall be parallel to each other. Rotary or Blanchard grinding modes are permitted for the side faces, but an additional final finishing step with a fine grinding wheel (600 grit or finer) and deeper final removal amounts than specified below may be necessary to eliminate prior grinding damage.

8.2.3.2 Stock removal rate shall not be greater than 0.03 mm per pass using diamond tools with a grit size range of 320 to 500. No less than 0.06 mm per face shall be removed during the final finishing phase, and a rate of not more than 0.002 mm per pass. Equal stock shall be removed from each side face where applicable.

8.2.3.3 Finer grinding wheels and lower material removal rates shall be used for materials with low fracture toughness values or materials that are susceptible to grinding damage.

8.2.3.4 All edges shall then be either chamfered at 45° to a distance of 0.12 ± 0.05 mm or rounded to a radius of 0.15 ± 0.05 mm to avoid ~~edge-dominated~~ edge-dominated failures. A final finishing step with 600 grit wheel may be beneficial.

8.2.4 ~~Micro-fabrication~~ Microfabrication Procedures—Miniature test specimens may be prepared by lithographic or other means. In all cases, the fabrication procedures should be chosen to minimize surface damage or residual stresses. The fabrication procedures should also be optimized to ensure dimensional uniformity of the test pieces. In particular, ~~through-thickness~~ through-thickness dimensional variations should be minimized whenever possible. Chamfers or edge beveling are not necessary for miniature test pieces if it can be verified that as-fabricated C-rings do not preferentially break from the corners.

8.2.5 The slot may be cut into the rings by any method that does not introduce gross damage to the test pieces. If the side faces of the test piece have been surface ground in accordance with 8.2.3.1, the slot shall be cut into the test specimen at a direction perpendicular to the surface grinding direction as shown in Fig. 2. This will align the side face surface grinding damage striations and cracks in a direction such that their influence is minimized. Since fracture is expected to occur on the opposite side of the test piece, the slot itself is not expected to influence the results. The slot height, L , (Figs. 1 and 2), shall be at least equal to the width, t , of the specimen to ensure that the slot is significantly greater than the maximum displacement at failure. When thin tubular specimens are studied, a larger slot not to exceed ~~one-fourth~~ one fourth of the outer circumference may be required.

<https://standards.iteh.ai/catalog/standards/sist/ceede3b8-d52d-4ce0-97cb-ef793e9082ce/astm-c1323-22>

8.3 *Handling Precaution*—Extreme care shall be used in storage and handling of all finished specimens to avoid the introduction of random and severe flaws from scratches, impacts with containers, or other specimens. In addition, attention shall be given to pre-test storage of specimens in controlled environments or desiccators to avoid unquantifiable environmental degradation of specimens prior to testing.

8.4 *Number of Specimens*—A minimum of ten tests is recommended for the purpose of estimating a mean. A minimum of 30 tests

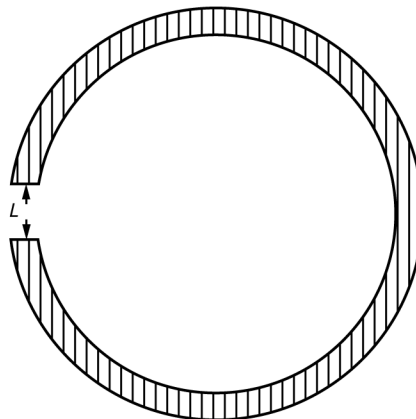

FIG. 2 C-Ring Slot and Surface Grinding Striation Patterns. The Slot Is Introduced at Right Angles to the Grinding Direction.

may be necessary if estimates regarding the form of the strength distribution and Weibull (12) parameters are desired within the confidence bounds established by Practice C1239.

9. Procedure

9.1 *Specimen Dimensions*—After machining the C-ring and slot, measure the outer diameter, inner diameter, wall thickness, and width of each machined specimen to within ± 0.01 mm or 1 % of the thickness, whichever is greater. Similar accuracy shall be achieved with as-fabricated specimens with the understanding that multiple measurements around the specimen shall be made to make allowance for eccentric or oval sections in as-fired C-rings. If the ring dimensions vary by more than 1 %, then measure the inner and outer diameters at several locations near to the slot. This procedure is adopted to make allowance for eccentric or oval sections in as-fired rings. A minimum of four measurements at equally spaced intervals with two at the load points are recommended. Divide each measured internal diameter by two to give the local nominal internal radius. Divide each measured outer diameter by two to give the local nominal outer radius. Compute the nominal wall thickness from the measured diameters and computed radii, or alternatively, measure the wall thickness at several locations. For both machined and as-fired C-rings, the wall thickness, t , shall be checked at the actual site of fracture after testing. For ~~micro-fabricated~~ microfabricated test pieces, measure the dimensions to within 1 %, and follow the above recommendations if any dimensional nonuniformities are detected.

9.1.1 Because each specimen's dimensions may vary, all stress and Weibull calculations should incorporate actual specimen dimensions.

9.2 Carefully position each specimen in the test fixture to minimize the possibility of damage and to ensure alignment. The specimen shall be directly centered below the axis of the applied loading. Loading points are at 90° and 270° as defined by Fig. 1. Marking the loading points with a pencil, nonreactive ink, or paint (such as “white-out”) is advisable. Marking micro test specimens is not required, but some scheme should be used to ensure test pieces are all loaded the same way, or that the angular alignment of the test pieces can be ascertained after testing. This step is required so that the stress adjustments in 10.1.2 can be performed if necessary.

9.3 Slowly apply the preload to the C-ring specimen. The maximum value of preload stress shall not exceed 25 % of the mean strength of the material under scrutiny. After the preload has been applied, always inspect the line of contact to ensure alignment, continuous contact, and the absence of contaminants. If the specimen is unable to be completely aligned or continuous contact between the platen and C-ring cannot be maintained, a self-adjusting fixture as described in 6.1.1 should be used.

9.4 *Loading Rates*—The crosshead rates are chosen in order that the strain rates experienced by the C-ring specimens are on the order of $1.0 \times 10^{-4} \text{ s}^{-1}$. Other crosshead rates may be used as appropriate (e.g., ~~for example~~, for assessment of slow crack growth sensitivity by testing at two or more rates as per Test Method C1368, or for testing micro test specimens), but the loading or crosshead rates and the rationale for the alternative rates shall be stated in the report.

9.4.1 *Strain Rate*—The maximum strain rate for a C-ring loaded in compression is as follows:

$$\dot{\varepsilon} = \frac{(r_o - r_i)^2}{6\pi r_a^3} \left[\frac{R(r_o - r_a)}{r_o(r_a - R)} \right] \dot{\delta} \quad (4)$$

where:

- $\dot{\varepsilon}$ = strain rate,
- b = specimen width,
- r_o = outer C-ring radius,
- r_i = ~~inner C-ring radius~~
- r_i = inner C-ring radius, and
- $\dot{\delta}$ = ~~crosshead speed, and~~
- $\dot{\delta}$ = crosshead speed.

~~the~~ The terms R and r_a (the average radius) are defined as:

$$R = \frac{(r_o - r_i)}{\ln\left(\frac{r_o}{r_i}\right)} \quad (5)$$

$$r_a = \frac{r_o + r_i}{2} \quad (6)$$