



Designation: D3675 – 22

# Standard Test Method for Surface Flammability of Flexible Cellular Materials Using a Radiant Heat Energy Source<sup>1</sup>

This standard is issued under the fixed designation D3675; the number immediately following the designation indicates the year of original adoption or, in the case of revision, the year of last revision. A number in parentheses indicates the year of last reappraisal. A superscript epsilon ( $\epsilon$ ) indicates an editorial change since the last revision or reappraisal.

## 1. Scope\*

1.1 This is a fire test response standard.

1.2 This test method describes the measurement of surface flammability of flexible cellular materials.

1.3 *This standard measures and describes the response of materials, products, or assemblies to heat and flame under controlled conditions, but does not, by itself, incorporate all factors required for fire hazard or fire risk assessment of the materials, products, or assemblies under actual fire conditions.*

1.4 *This standard does not purport to address all of the safety concerns, if any, associated with its use. It is the responsibility of the user of this standard to establish appropriate safety, health, and environmental practices and determine the applicability of regulatory limitations prior to use.*

1.5 *Fire testing is inherently hazardous. Adequate safeguards for personnel and property shall be employed in conducting these tests.*

1.6 Specific information about hazards is given in Section 7.

NOTE 1—There is no known ISO equivalent to this standard.

1.7 The values stated in SI units are to be regarded as the standard. The values stated in inch-pound units, in parentheses, are for information only and are approximations (see also [IEEE/ASTM SI-10](#)).

1.8 *This international standard was developed in accordance with internationally recognized principles on standardization established in the Decision on Principles for the Development of International Standards, Guides and Recommendations issued by the World Trade Organization Technical Barriers to Trade (TBT) Committee.*

## 2. Referenced Documents

2.1 *ASTM Standards:*<sup>2</sup>

[D883 Terminology Relating to Plastics](#)

<sup>1</sup> This test method is under the jurisdiction of ASTM Committee [D20](#) on Plastics and is the direct responsibility of Subcommittee [D20.30](#) on Thermal Properties.

Current edition approved March 15, 2022. Published March 2022. Originally approved in 1978. Last previous edition approved in 2021 as D3675 – 21a. DOI: 10.1520/D3675-22.

<sup>2</sup> For referenced ASTM standards, visit the ASTM website, [www.astm.org](http://www.astm.org), or contact ASTM Customer Service at [service@astm.org](mailto:service@astm.org). For *Annual Book of ASTM Standards* volume information, refer to the standard's Document Summary page on the ASTM website.

[E84 Test Method for Surface Burning Characteristics of Building Materials](#)

[E162 Test Method for Surface Flammability of Materials Using a Radiant Heat Energy Source](#)

[E176 Terminology of Fire Standards](#)

[E456 Terminology Relating to Quality and Statistics](#)

[E1317 Test Method for Flammability of Surface Finishes](#)

[E1321 Test Method for Determining Material Ignition and Flame Spread Properties](#)

[E1546 Guide for Development of Fire-Hazard-Assessment Standards](#)

[IEEE/ASTM SI-10 Standard for Use of the International System of Units \(SI\): The Modern Metric System](#)

2.2 *ISO Standards:*<sup>3</sup>

[ISO 13943 Fire Safety—Vocabulary](#)

## 3. Terminology

3.1 *Definitions:*

3.1.1 For definitions of terms relating to plastics, the definitions in this test method are in accordance with Terminology [D883](#). For terms relating to fire, the definitions in this test method are in accordance with Terminology [E176](#) and ISO 13943. In case of conflict, the definitions given in Terminology [E176](#) shall prevail. For terms relating to precision and bias and associated issues, the terms used in this test method are in accordance with the definitions in Terminology [E456](#).

3.1.2 *flame front, n*—the leading edge of a flame propagating through a gaseous mixture or across the surface of a liquid or solid.

3.2 *Definitions of Terms Specific to This Standard:*

3.2.1 *flashing, n*—flame fronts of three seconds or less in duration.

3.2.2 *radiant panel index,  $I_s$ , n*—the product of the flame spread factor,  $F_s$ , and the heat evolution factor,  $Q$ .

## 4. Summary of Test Method

4.1 This test method of measuring surface flammability of flexible cellular materials employs a radiant panel heat source consisting of a 300 by 460-mm (12 by 18-in.) panel in front of

<sup>3</sup> Available from International Standardization Organization, P.O. Box 56, CH-1211; Geneva 20, Switzerland.

\*A Summary of Changes section appears at the end of this standard

which an inclined 150 by 460-mm (6 by 18-in.) specimen of the material is placed. The orientation of the specimen is such that ignition is forced near its upper edge and the flame front progresses downward.

4.2 Factors derived from the rate of progress of the flame front and the rate of heat liberated by the material under test are combined to provide a radiant panel index.

## 5. Significance and Use

5.1 This test method is intended for use when measuring surface flammability of flexible cellular materials exposed to fire. The test method provides a laboratory test procedure for measuring and comparing the surface flammability of materials when exposed to a prescribed level of radiant heat energy. The test is conducted using specimens that are representative, to the extent possible, of the material or assembly being evaluated. For example, if an assembly is required to be tested, such specimens shall replicate the type and thickness of all the layers present in the assembly being evaluated.

5.2 The rate at which flames will travel along surfaces depends upon the physical and thermal properties of the material, product, or assembly under test, the specimen mounting method and orientation, the type and level of fire or heat exposure, the availability of air, and properties of the surrounding enclosure. (1-6)<sup>4, 5</sup>

5.3 Test Method E162 is a generic version of this test method, using an apparatus that is substantially the same as the one used in this test method. However, Test Method E162 is normally intended for application to specimens other than flexible cellular materials.

5.3.1 The pilot burner in this test method is different from the pilot burner in Test Method E162.

5.4 In this procedure, the specimens are subjected to one or more specific sets of laboratory fire test conditions. If different test conditions are substituted or the end-use conditions are changed, it is not always possible by or from this test to predict changes in the fire-test-response characteristics measured. Therefore, the results are valid only for the fire test exposure conditions described in this procedure.

5.5 If the test results obtained by this test method are to be considered as part of an overall assessment of fire hazard in a building or structure, then the criteria, concepts and procedures incorporated into Guide E1546 shall be taken into consideration.

## 6. Apparatus

6.1 The apparatus shall be essentially as shown in Fig. 1 and shall include the following:

6.1.1 *Radiant Panel with Air and Gas Supply*—The radiant heat energy source shall be a panel that consists of a porous material mounted in a suitable frame, exposing a radiating surface of 300 by 460 mm (12 by 18 in.). The radiant heat energy source shall be capable of operating at temperatures up

to 820°C (1500°F). The panel shall be equipped (see Fig. 1) with a venturi-type aspirator for mixing gas and air at approximately atmospheric pressure; a centrifugal blower, or equivalent, capable of providing 9.4 dm<sup>3</sup>/s (1200 ft<sup>3</sup>/hour) air at a pressure of 0.7 kPa (2.8 in. water); an air filter to prevent dust from obstructing the panel pores; a pressure regulator and a control and shut-off valve for the gas supply.

6.1.2 *Specimen Holder*—The specimen holder shall conform in shape and dimension to Fig. 2 and be constructed from heat-resistant chromium steel, or other suitable non-combustible material which will not be affected by the heat input during the test. Observation marks shall be filed on the surface of the specimen holder to correspond with 75-mm (3-in.) interval lines on the specimen.

6.1.2.1 The calibration process (see A1.2) shall be conducted with the specimen holder to be used in the tests to ensure that the physical characteristics of the construction material do not affect the test results.

6.1.3 *Framework for Support of the Specimen Holder*—The framework shall have two transverse rods of stainless steel, each 12.5 mm ± 3.0 mm (0.5 ± 0.13 in.) in diameter, with a stop to center the specimen holder directly in front of the radiant panel. The support and bracing members shall be constructed from metal stock. Since the angle of the specimen and its position with respect to the panel are critical, the framework dimensions specifying these conditions shall be within 3.0 mm (0.13 in.) of the values given in Fig. 1.

6.1.4 *Pilot Burner*—The pilot burner shall be a porcelain tube 203-230 mm (8-9 in.) in length, nominally 6.3 mm (0.25 in.) in diameter, with two holes 1.5 ± 0.1 mm (0.059 ± 0.004 in.) in diameter equally spaced in the tube (see Fig. 3). The burner shall be mounted horizontally and at an angle of 15 to 20° to the intersection of the horizontal plane of the burner with the plane of the specimen with the outlet end of the burner spaced 32 ± 2 mm (1.25 ± 0.1 in.) from the specimen (see Fig. 3). The pilot shall provide a 150 to 180-mm (6 to 7-in.) flame of acetylene gas premixed with air in an aspirating type fitting. Properly adjusted, the pilot flame shall have 25-mm (1-in.) inner blue cones and should impinge on the upper central surface of the specimen within 13 mm (0.5 in.) of the edge of the specimen support frame. Flow rates of 0.015 dm<sup>3</sup>/s (0.032 ft<sup>3</sup>/min) of acetylene and 0.075 dm<sup>3</sup>/s (0.16 ft<sup>3</sup>/min) of air have been found to provide the desired flame.

6.1.5 *Stack*—The stack shall be made from nominally 1.0-mm (0.040-in.) sheet steel with shape and dimensions as shown in Fig. 1. The position of the stack with respect to the specimen and radiant heat panel shall also comply with the requirements of Fig. 1.

6.1.6 *Thermocouples*—Eight thermocouples of equal resistance shall be mounted in the stack and supported with porcelain insulators as indicated in Fig. 1 and Fig. 4. The thermocouples shall be Chromel-Alumel Type K, shielded against high heat with insulation resisting up to 1200°C (2190°F), and with wire gages in the range of 0.36-0.51 mm (0.14-0.20 in.) (30 AWG-24 AWG) diameter and shall be connected in parallel, or recorded individually and then averaged, such that a mean temperature profile of the stack is achieved. The mean stack thermocouple temperature rise for

<sup>4</sup> The boldface numbers in parentheses refer to a list of references at the end of this standard.

<sup>5</sup> Also see Test Method E162.

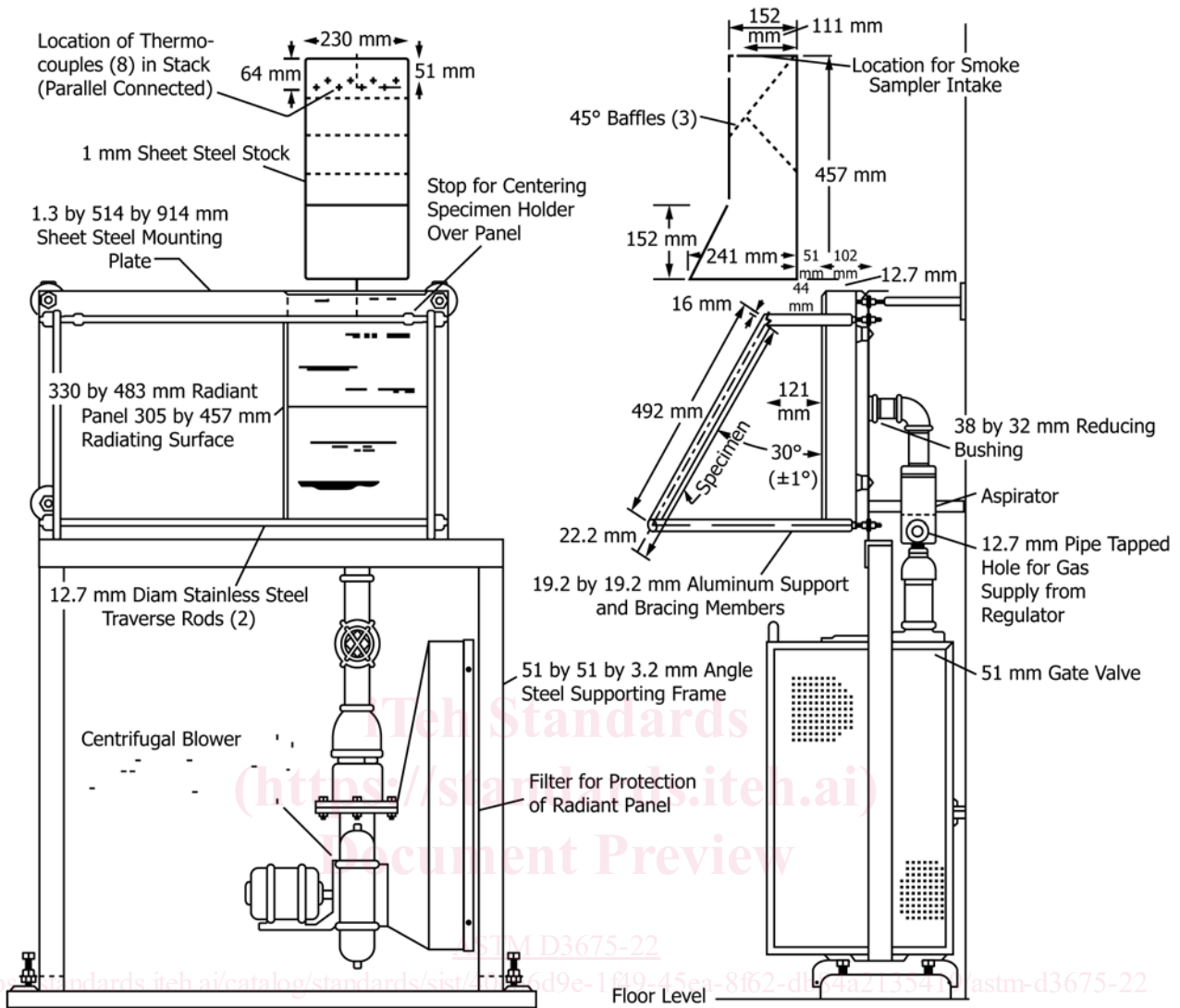

Metric Equivalents

mm	in.	mm	in.
1.0	0.040	152	6
12.7	1/2	241	9 1/2
16.0	5/8	457	18
22.2	7/8	492	19 3/8
44	1 3/4	19.1 by 19.	3/4 by 3/4
51	2	38 by 32	1 1/2 by 1 1/4
64	2 1/2	305 by 457	12 by 18
71	2.8	330 by 483	13 by 19
102	4	51 by 51 by 3.2	2 by 2 by 1/8
111	4 3/8	1.3 by 514 by 914	0.050 by 20 1/4 by 36
121	4 3/4		

100 cfm 47.21 litres/s

FIG. 1 Details of Construction of Test Equipment

unit heat input rate of the calibration burner,  $\beta$ , shall be determined periodically for the specific test apparatus, using the procedure in Annex A1.

6.1.7 *Automatic Potentiometer Recorder*—An automatic potentiometer recorder in the range from 38 to 538°C (100 to 1000°F) shall be installed to record the temperature variation of the stack thermocouples as described in 6.1.6. Alternatively,

a computerized data acquisition system shall be permitted to be used. The data acquisition system shall have facilities to record the temperature output from the thermopile. The data acquisition system shall have an accuracy of 0.01 % of the maximum temperature to be measured. Whichever system is used, it shall be capable of recording, or printing, data at least every 5 s for a minimum of 1 h. For cases where preliminary tests indicate

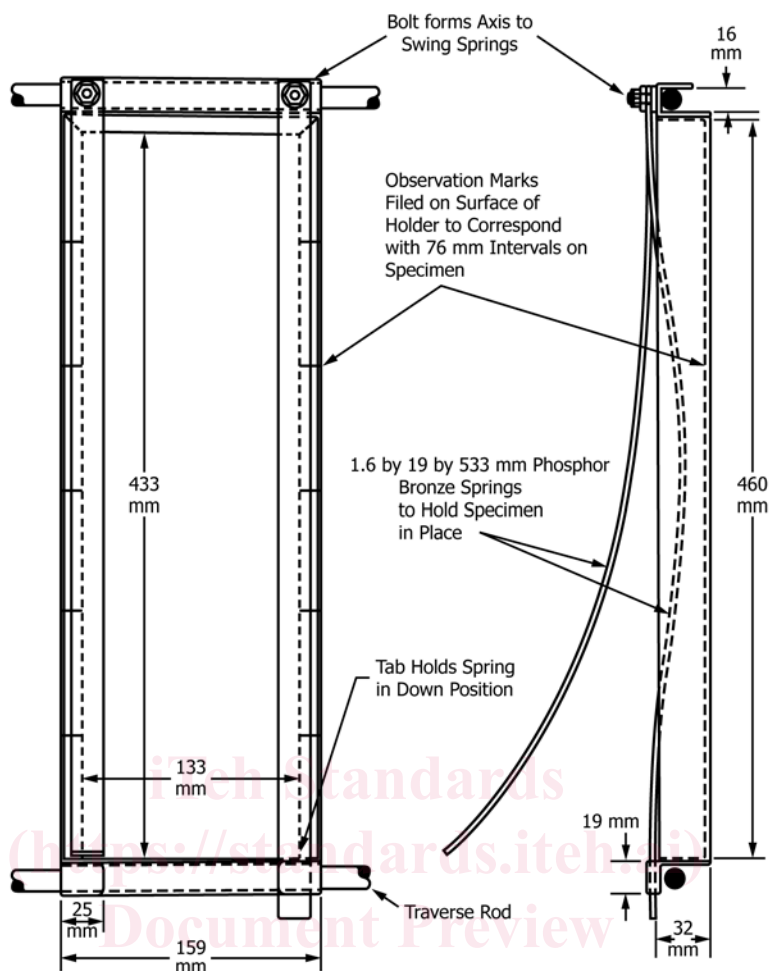

ASTM D3675 - 22  
Metric Equivalents

mm	in.	mm	in.
19.0	¾	159	6 ¼
25	1	433	17 ⅝
32	1 ¼	460	18 ⅛
76	3	1.6 by 19 by 533	⅛ by ¾ by 21
133	5 ¼		

FIG. 2 Specimen Holder

rapid flame spread, a system shall be used capable of acquiring data fast enough to ensure adequate results (see 11.6).

6.1.8 Hood—A hood with exhaust blower placed over the stack is required. Before igniting the panel, but with the exhaust hood operating, the air flow rate through the stack shall produce a nominal velocity of 0.5 m/s (100 ft/min, 30 m/min). Measurements are to be made either with a hot wire anemometer after at least 30 seconds of insertion of the probe into the center of the stack at a distance of 152 mm (6 in.) down from the top of the stack opening, or with a bi-directional probe or similar device at the top of the stack opening. The hot wire anemometer, bi-directional probe or similar device, shall have an accuracy of ±0.1 m/s (19 ft/min).

6.1.8.1 In order to facilitate the insertion of the hot wire anemometer probe, a hole of adequate diameter to allow its insertion shall be pre-drilled through the hood, in the center of

either of the 152 mm (6 in.) wide surfaces, so as to prevent contact of the probe with the internal baffles. The hole is intended to be used for insertion of the probe and shall be plugged after the air flow rate has been established and before testing.

6.1.8.2 The velocity is not critical for flame spread measurements provided a stack thermocouple calibration is performed (see 6.1.6 and A1.2) for the established test conditions. The hood surfaces shall clear the top and sides of the stack by a minimum of 250 mm (10 in.) and 190 mm (7.5 in.), respectively.

6.1.8.3 Testing has shown that the air flow rate through the stack, if measured during operating conditions using a bi-directional probe or similar device, produces a velocity of approximately 1.3 m/s (250 ft/min).

TOP VIEW OF PILOT BURNER

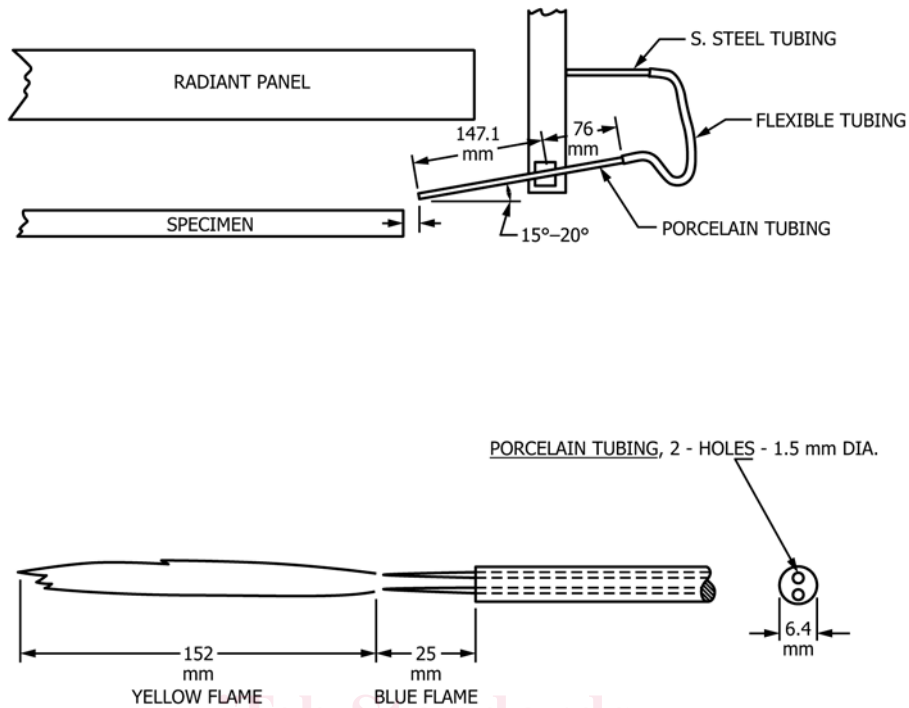

FIG. 3 Pilot Burner

6.1.9 *Radiation Pyrometer*—The radiation pyrometer for standardizing the thermal output of the panel shall be suitable for viewing a circular area 250 mm (10 in.) in diameter at a range of about 1.2 m (4 ft). It shall be calibrated over the operating black body temperature range in accordance with the procedure described in Annex A1.

6.1.10 *Portable Potentiometer*—The electrical output of the radiation pyrometer shall be monitored by means of a potentiometer provided with a millivolt range suitable for use with the radiation pyrometer described in 6.1.9. Alternatively, the data shall be permitted to be recorded with a computerized data acquisition unit, as discussed in 6.1.7.

6.1.11 *Timer*—The timer shall be calibrated to read to 0.01 min to record the time of events during the test.

7. Hazards

7.1 Safeguards shall be installed in the panel fuel supply system to guard against a gas air fuel explosion in the test chamber. Potential safeguards include, but are not limited to, one or more of the following: a gas feed cut-off activated when the air supply fails; a flame sensor directed at the panel surface that stops fuel flow when the panel flame goes out; and a heat detector mounted in contact with the radiant panel plenum that is activated when the panel temperature exceeds safe limits. Manual reset is a requirement of any safeguard system used.

7.2 The exhaust system must be so designed and operated that the laboratory environment is protected from smoke and gas. The operator shall be instructed on ways to minimize exposure to combustion products by following sound safety and industrial hygiene practices. For example, ensure that the

exhaust system is working properly and wear appropriate clothing including gloves, safety glasses, breathing apparatus (when hazardous fumes are expected).

7.3 During this test, very high heat fluxes and high temperatures are generated that are capable of igniting some clothing following even brief exposures. Precautions shall be taken to avoid ignitions of this type.

8. Test Specimens

8.1 The test specimens shall be 150 by 460 by 25 mm (6 by 18 by 1.0 in.). Materials produced at less than 25-mm thickness shall be tested at the maximum thickness produced. Materials produced at less than 460 mm (18 in.) in length shall be mounted in series to provide a specimen of the proper length. No segment of the specimen shall be less than 150 mm (6 in.) in length.

8.2 After cutting or sawing to prepare test specimens, care shall be taken to remove dust and particles from the test specimen surface.

8.3 The back and sides of the test specimen shall be wrapped with aluminum foil, the shiny side against the test specimen, 0.05 mm (0.002 in.) nominally in thickness. High density inorganic reinforced cement board, nominally 6.4 mm (0.25 in.) in thickness, shall be used as backing. The test specimen shall be retained in the specimen holder by a nominally 150 by 460-mm (6 by 18-in.) sheet of nominally 25-mm (1-in.) 20-gage hexagonal steel wire mesh placed against the exposed face of the specimen. Molded skin or treated surfaces shall face the exposure.

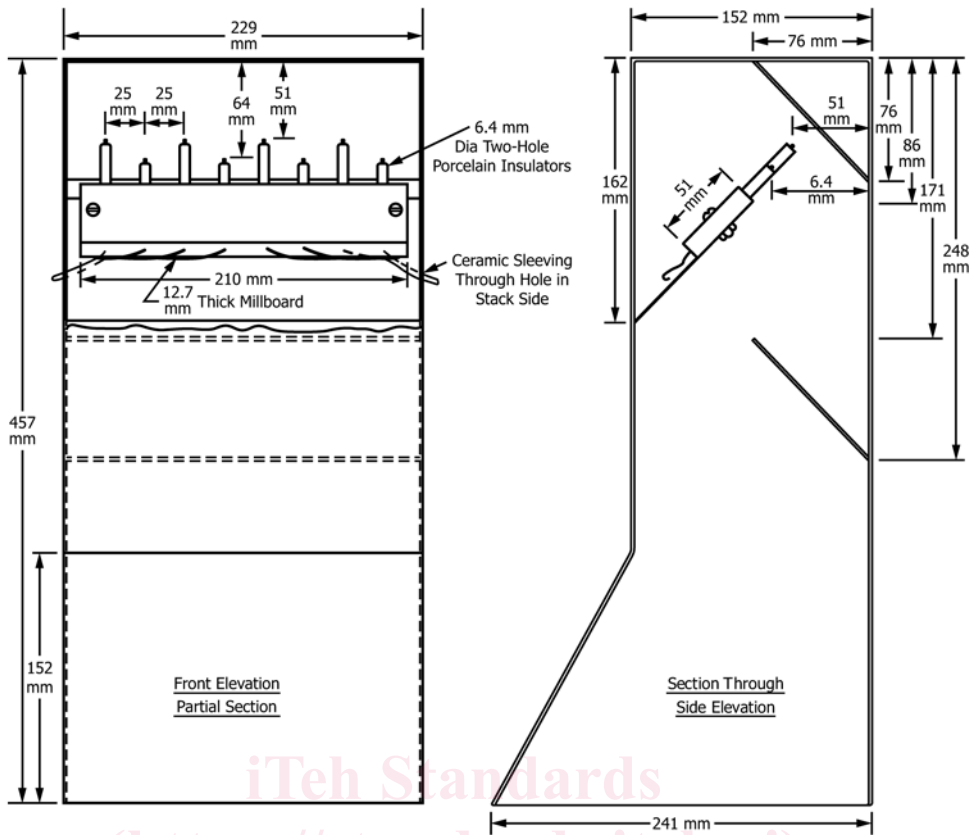

Metric Equivalents

mm	in.	mm	in.	mm	in.
6.4	1/4	76	3	229	9
12.7	1/2	86	3 3/8	241	9 1/2
25	1	152	6	248	9 3/4
51	2	171	6 3/4	457	18
64	2 1/2	210	8 1/4		

FIG. 4 Thermocouple Mounting Arrangement

NOTE 2—Aluminum foil is used against the specimen to prevent melting and destroying the back board/holders.

NOTE 3—Wherever inorganic reinforced cement board is specified, the material shall be nominally 6 mm (0.25 in.) thick, high density (1762 ± 80 kg/m<sup>3</sup> (110 ± 5 lb/ft<sup>3</sup>)) and uncoated.

NOTE 4—Test Method E162 (from which this test method was developed as a modification, see Appendix X1) requires that specimens less than 19.0 mm (3/4 in.) thick, be tested using a wood substrate as backing. This requirement does not apply to flexible cellular materials tested using this test method.

8.4 Four test specimens of each sample shall be tested. If one or more tests are deemed to be invalid, additional tests shall be conducted until four valid test results have been developed.

## 9. Conditioning

9.1 Condition the specimens for a minimum of 24 h at a temperature of 23 ± 3°C (73 ± 5°F) and a relative humidity of 50 ± 5%.

9.2 Maintain the ambient conditions for the test apparatus at 23 ± 5°C. Keep the test specimens in an enclosure at 23 ± 2°C

and 50 ± 5% RH and take the test specimens out of the enclosure just before testing (so that testing is conducted within 30 minutes of the test specimen removal from the conditioning environment).

## 10. Procedure

10.1 Remove combustion product deposits from the thermocouples by brush cleaning or other effective method after each test.

10.2 At the start of each day, ignite the gas-air mixture passing through the radiant panel and allow the unit to heat for at least 0.5 h. Before each test, check the radiant output by means of the radiation pyrometer. Do this by placing the pyrometer in such a manner as to view a central panel area about 250 mm (10 in.) in diameter. Adjust the rate of air supply to between 750 and 800 ft<sup>3</sup>/h (5.9 and 6.3 L/s) and then adjust the fuel gas supply upwards from zero until it is just sufficient to produce a radiant output equal to that which would be obtained from a blackbody of the same dimensions operating at a temperature of 670 ± 4°C (1238 ± 7°F).

10.3 Turn on the recording potentiometer for measuring the stack thermocouple temperature.

10.4 Ignite the pilot and adjust it to give a flame 150 to 180 mm (6 to 7 in.) long with inner blue cones 25 mm (1.0 in.) in length.

10.5 Place the specimen holder containing the specimen into the supporting framework and start the timer simultaneously. A maximum of 5 min shall lapse between the time the specimen is removed from the conditioning chamber until it is placed in position on the framework.

10.6 Record the time of arrival of the flame at each of the 75-mm (3-in.) marks on the specimen holder. Also record the maximum temperature rise of the stack thermocouples.

10.7 Record any observations made of any behavior characteristics of a specimen that appear to be of interest.

10.8 *Exposure Time*—The test is completed when the flame front has progressed to the 375 mm (15 in.) mark on the specimen or after an exposure time of 15 min, whichever occurs earlier, provided the maximum temperature of the stack thermocouples is reached. After 15 minutes have elapsed and the maximum surface flame spread has been recorded, the test shall be discontinued if the stack temperature has increased by no more than 5°C over any five-minute measuring period after the initial 15-minute exposure period has elapsed. The maximum temperature shall be recorded as the maximum temperature measured before the test is discontinued.

10.9 If during the test of one or more of the test specimens, any of the behaviors identified in 10.9.1 through 10.9.5 occurs, the test is invalid. Then test an additional specimen of the identical preconditioned test specimens. Do not incorporate data obtained from invalid tests, yielding inadequate results, in the averaged data, but report the occurrence.

10.9.1 The specimen falls out of the specimen holder.

10.9.2 Most of the test specimen melts out of the specimen holder.

10.9.3 Explosive spalling forcefully displaces the specimen from the zone of controlled irradiance.

10.9.4 The test specimen swells sufficiently prior to ignition to touch the panel during combustion.

10.9.5 Materials exhibit rapid running or dripping of flaming material at any time during the test. This shall be assessed if flaming droplets fall away from the test samples at a rate of one drop per second (or faster), lasting for a continuous duration of ten seconds (or longer).

## 11. Calculation

11.1 Calculate the radiant panel index,  $I_s$ , of a specimen as the product of the flame spread factor,  $F_s$ , and the heat evolution factor,  $Q$ , as shown in:

$$I_s = F_s Q \quad (1)$$

where  $F_s$  and  $Q$  are as defined in 11.2 and 11.3.

11.2 *Calculation of  $F_s$* —On linear graph paper, plot distance vertically against time of arrival of flame at each mark horizontally. For this purpose, assume that the flame starts at 0 in. (0 mm) at time 0 s, and plot this initial point also. Connect

the six (or fewer) points with straight-line segments. If the upward slope of all the line segments becomes less steep, or remains constant, calculate  $F_s$  as shown in:

$$F_s = 1 + \frac{1}{t_3 - t_0} + \frac{1}{t_6 - t_3} + \frac{1}{t_9 - t_6} + \frac{1}{t_{12} - t_9} + \frac{1}{t_{15} - t_{12}} \quad (2)$$

where  $t_0$  is conventionally 0, and  $t_3 \dots t_{15}$  correspond to the time, in minutes, from initial specimen exposure until arrival of the flame front at the positions 3 ... 15 in. (76 ... 380 mm), respectively, along the length of the specimen.

11.2.1 If there are any segments where the slope increases eliminate the increase by drawing a straight line from the previous point to the succeeding point, thus “skipping” the point at which the slope increases (so, a “skip point” will always be located *below* the new line segment). Repeat this as often as necessary to eliminate slope increases. In some cases it will be necessary to skip 2, 3, or 4 consecutive points.

11.2.2 Points that are left below the final segmented curve are designated “skip points.” Points on the curve are “curve points.” If there are any points above the curve, this is an indication of errors. Using the equation for  $F_s$  given in 11.2, drop the two terms involving a single skip point, or the three to five terms involving two to four consecutive skip points, or both, and in each case replace them with the single new term  $K/(T_f - T_b)$  where  $K$  is an integer related to the number of skip points, as follows:

Number of Skip Points	$K$
One single	4
Two consecutive	9
Three consecutive	16
Four consecutive	25

(Note that it is possible to have two, but no more, distinct groups of skip points.)

$T_f$  = time in minutes at the first curve point following skip point.

$T_b$  = time in minutes at the last curve point before a skip point.

11.2.3 Procedures equivalent to the preceding, for example computer programs, are equally valid.

11.3 Calculate  $Q$  as shown in:

$$Q = CT/\beta \quad (3)$$

where:

$C$  = arbitrary constant 5.7, chosen to make results consistent with those obtained prior to the metrication of this calculation,

$T$  = observed maximum stack thermocouple temperature difference in degrees Celsius between the temperature-time curve for the specimen and that for a similar curve of the inorganic reinforced cement board calibration specimen (see A1.2), and

$\beta$  = mean stack thermocouple temperature rise for unit heat input rate of the calibration burner in degrees Celsius per kilowatt, a constant for the apparatus (see A1.2). ( $\beta$  will probably be found to lie between 0.6 and 1.2°F/Btu-min, or between 20 and 40°C/kW.)

NOTE 5—For those using English units, arbitrary constant  $C = 0.1$ ,  $T$  shall be expressed in °F, and  $\beta$  shall be expressed in °F per Btu/min.

NOTE 6—The value of radiant panel index,  $I_s$ , is independent of the system of units used.