



Designation: F2670 – 22

# Standard Consumer Safety Specification for Infant Bath Tubs<sup>1</sup>

This standard is issued under the fixed designation F2670; the number immediately following the designation indicates the year of original adoption or, in the case of revision, the year of last revision. A number in parentheses indicates the year of last reapproval. A superscript epsilon ( $\epsilon$ ) indicates an editorial change since the last revision or reapproval.

## INTRODUCTION

This consumer safety specification addresses incidents associated with infant bath tubs and infant bath tub accessories identified by the U.S. Consumer Product Safety Commission (CPSC).

In response to incident data compiled by the CPSC, this specification attempts to minimize the following hazards: infant bath tubs being used in adult tubs containing water and left unattended by their caregiver, collapse of infant bath tubs, drowning incidents with accessories being used in or on infant bath tubs, and collapse and structural failure of accessories.

This specification is intended to cover normal use and reasonably foreseeable misuse or abuse of the products.

This consumer safety specification is written within the current state-of-the-art of infant bath tub and infant bath tub accessory technology and will be updated whenever substantive information becomes available that necessitates additional requirements or justifies the revision of existing requirements.

## 1. Scope

1.1 This consumer safety specification establishes performance requirements, test methods, and labeling requirements to promote the safe use of infant bath tubs. It also covers slings, pads, inserts, and similar accessories when such accessories are used with the infant bath tub.

1.2 This consumer safety specification is intended to reduce the risk of death and minimize injury to infants resulting from use and reasonably foreseeable abuse of infant bath tubs and infant bath tub accessories.

1.3 No infant bath tub or infant bath tub accessory produced after the approval date of this consumer safety specification shall, either by label or other means, indicate compliance with this specification unless it conforms to all requirements contained herein.

1.4 The values stated in inch-pound units are to be regarded as standard. The values given in parentheses are mathematical conversions to SI units that are provided for information only and are not considered standard.

1.5 The following precautionary caveat pertains only to the test methods portion, Section 7, of this consumer safety

specification: *This standard does not purport to address all of the safety concerns, if any, associated with its use. It is the responsibility of the user of this standard to establish appropriate safety, health, and environmental practices and determine the applicability of regulatory limitations prior to use.*

1.6 *This international standard was developed in accordance with internationally recognized principles on standardization established in the Decision on Principles for the Development of International Standards, Guides and Recommendations issued by the World Trade Organization Technical Barriers to Trade (TBT) Committee.*

## 2. Referenced Documents

2.1 *ASTM Standards:*<sup>2</sup>

[D1683/D1683M Test Method for Failure in Sewn Seams of Woven Fabrics](#)

[D3359 Test Methods for Rating Adhesion by Tape Test](#)

[F963 Consumer Safety Specification for Toy Safety](#)

2.2 *Federal Standards:*<sup>3</sup>

[16 CFR 1303 Ban of Lead-Containing Paint and Certain Consumer Products Bearing Lead Containing Paint](#)

<sup>1</sup> This consumer safety specification is under the jurisdiction of ASTM Committee F15 on Consumer Products and is the direct responsibility of Subcommittee F15.20 on Bath Seats.

Current edition approved March 1, 2022. Published March 2022. Originally approved in 2009. Last previous edition approved in 2018 as F2670 – 18. DOI: 10.1520/F2670-22.

<sup>2</sup> For referenced ASTM standards, visit the ASTM website, [www.astm.org](http://www.astm.org), or contact ASTM Customer Service at [service@astm.org](mailto:service@astm.org). For *Annual Book of ASTM Standards* volume information, refer to the standard's Document Summary page on the ASTM website.

<sup>3</sup> Available from U.S. Government Printing Office Superintendent of Documents, 732 N. Capitol St., NW, Mail Stop: SDE, Washington, DC 20401, <http://www.access.gpo.gov>.

16 CFR 1500 Federal Hazardous Substances Act Regulations

16 CFR 1500.48 Technical Requirements for Determining a Sharp Point in Toys and Other Articles Intended for Use by Children Under 8 Years of Age

16 CFR 1500.49 Technical Requirements for Determining a Sharp Metal or Glass Edge in Toys and Other Articles Intended for Use by Children Under 8 Years of Age

16 CFR 1501 Method for Identifying Toys and Other Articles Intended for Use by Children Under 3 Years of Age Which Present Choking, Aspiration, or Ingestion Hazards Because of Small Parts

2.3 ANSI Standard:

ANSI Z535.1 Safety Colors

ANSI Z535.4 Product Safety Signs and Labels

ANSI Z535.6 Product Safety Information in Product Manuals, Instructions, and Other Collateral Materials

### 3. Terminology

3.1 *Definitions of Terms Specific to This Standard:*

3.1.1 *conspicuous, adj*—visible, when the occupant is in the product and the product is in any manufacturer’s recommended use position(s), to a person standing near the product at any one position around the product, but not necessarily visible from all positions.

3.1.2 *double-action release system, n*—a mechanism requiring either two consecutive actions, the first of which must be maintained while the second is carried out, or two separate and independent simultaneous actions to fully release.

3.1.3 *fabric, n*—any woven, knit, coated, laminated, extruded or calendered flexible material that is intended to be assembled using a seam.

3.1.4 *infant bath tub, n*—tub, enclosure, or other similar product intended to hold water and be placed into an adult bath tub, sink, or on top of other surfaces to provide support or containment, or both, for an infant in a reclining, sitting, or standing position during bathing by a caregiver.

3.1.5 *infant bath tub accessory, n*—component or product sold with an infant bath tub or sold separately and that is intended to be attached to or placed on or in an infant bath tub for the purpose of supporting an infant during bathing by an adult caregiver.

3.1.5.1 *Discussion*—Such component or product may also be intended for use separately as a standalone product, but that use mode is not covered by this consumer safety specification. Other components or products not intended to support an infant while being bathed (for example, soap or towel holder, water pump, shower handle, etc.) are excluded from this definition.

3.1.6 *latching and locking mechanism, n*—method of preventing an infant bath tub from folding or collapsing during use.

3.1.7 *manufacturer’s recommended use position(s), n*—any position that is presented as a normal, allowable, or acceptable configuration for the use of the product by the manufacturer in any descriptive or instructional literature.

3.1.7.1 *Discussion*—This specifically excludes positions

which the manufacturer shows in a like manner in its literature to be unacceptable, unsafe, or not recommended.

3.1.8 *nonpaper label, n*—any label material, such as plastic or metal, that either will not tear without the aid of tools or tears leaving a sharply defined edge or labels made of fabric.

3.1.9 *occupant, n*—infant that is in an infant bath tub or an infant bath tub accessory in any manufacturer’s recommended use position(s).

3.1.10 *paper label, n*—any label material that tears without the aid of tools and leaves a fibrous edge.

3.1.11 *principal display panel, n*—that part of the product’s package that is most likely to be displayed, presented, shown or examined under normal or customary conditions of display for retail sale.

3.1.12 *product, n*—when used in this standard, means that requirements apply to both an infant bath tub and an infant bath tub accessory.

3.1.13 *protective component, n*—any component used for protection from sharp edges, points, or entrapment of fingers or toes.

3.1.13.1 *Discussion*—Examples of protective components include caps, sleeves, and plugs.

3.1.14 *seam, n*—means of joining fabric components such as sewing, welding, heat sealing, or gluing.

3.1.15 *smooth test surface, n*—any rigid plastic, metal, or porcelain surface to which the suction cups can adhere, and that is at least 2 in. (51 mm) larger in all directions than the largest dimensions of the suction cup attachment device on the infant bath tub.

3.1.16 *static load, n*—vertically downward load applied by weights or other means.

### 4. Calibration and Standardization

4.1 Unless otherwise noted, the product shall be completely assembled in accordance with the manufacturer’s instructions.

4.2 The product to be tested shall be in a room with an ambient temperature of 73 °F ± 9 °F (23 °C ± 5 °C) for at least 1 h prior to testing. Testing then shall be conducted within this temperature range.

4.3 All testing required by this consumer safety specification shall be conducted on the same product sample, unless otherwise specified.

### 5. General Requirements

5.1 *Hazardous Sharp Edges or Points*—There shall be no hazardous sharp points or edges as defined in 16 CFR 1500.48 and 16 CFR 1500.49 before or after the product has been tested to this consumer safety specification.

5.2 *Small Parts*—There shall be no small parts as defined in 16 CFR 1501 before testing or liberated as a result of testing to this consumer safety specification.

5.3 *Lead in Paints*—All paint and surface coatings on the product shall comply with the requirements of 16 CFR 1303.

5.4 *Latching and Locking Mechanism(s)*:

5.4.1 When the product is placed in any manufacturer's recommended use position(s), products that fold shall have a latching and locking mechanism(s) or other means to prevent the product from folding or collapsing in a manner that puts the occupant at risk of injury by falling out of the product or being subjected to contact or pressure by product components.

NOTE 1—"Other means" could include, but are not limited to, designs which utilize the occupant, an added component, or the water that is placed into the product to act in opposition to the folding action or collapse of the product.

5.4.2 When the product is placed in any manufacturer's recommended use position(s), latching and locking mechanism(s) shall comply with either 5.4.2.1 or 5.4.2.2.

5.4.2.1 Product shall be designed with a single-action release mechanism(s) that, when tested in accordance with 7.1.1, shall remain engaged and operative.

5.4.2.2 Product shall be designed with a double-action release system.

5.4.3 During and upon completion of the test in accordance with 7.4, the infant bath tub shall remain in the manufacturer's recommended use position(s), and the latching and locking mechanism(s) shall remain engaged and operative.

5.4.4 During and upon completion of the test in accordance with 7.4.1, 7.6.1, and 7.6.2, the infant bath tub accessory shall remain in the manufacturer's recommended use position(s), and the latching and locking mechanism(s) shall remain engaged and operative.

5.4.5 Latching and locking mechanism(s) shall also comply with the requirements of this section (5.4) after cycling has been conducted in accordance with 7.1.2.

5.5 *Scissoring, Shearing, and Pinching*—The product, when in the manufacturer's recommended use position(s), shall be designed and constructed to prevent injury to the occupant from any scissoring, shearing, or pinching when members or components rotate about a common axis or fastening point, slide, pivot, fold or otherwise move relative to one another. Scissoring, shearing, or pinching that may cause injury exists when the edges of the rigid parts admit a probe greater than 0.210 in. (5.33 mm) and less than 0.375 in. (9.53 mm) at any accessible point throughout the range of motion of such parts.

5.6 *Openings*—Holes or slots that extend entirely through a wall section of any rigid material less than 0.375 in. (9.53 mm) thick and admit a 0.210-in. (5.33 mm) diameter rod shall also admit a 0.375 in. (9.53 mm) diameter rod. Holes or slots that are between 0.210 in. (5.33 mm) and 0.375 in. (9.53 mm) and have a wall thickness less than 0.375 in. (9.53 mm) but are limited in depth to 0.375 in. (9.53 mm) maximum by another rigid surface shall be permissible (see Fig. 1 for examples). The product shall be evaluated in all manufacturer's recommended use positions.

5.7 *Protective Components*—If the child can grasp any protective components between the thumb and forefinger, or teeth, or if there is at least a 0.04 in. (1.0 mm) gap between the component and its adjacent parent component when the infant bath tub with and without any accessories (if applicable) is in its manufacturer's recommended use position(s), such component shall not be removed when tested in accordance with 7.2.

5.8 *Requirements for Toys*—Toy accessories attached to, removable from, or sold with either infant bath tubs or infant bath tub accessories, or both, as well as their means of attachment, shall meet applicable requirements of Consumer Safety Specification F963.

5.9 *Labeling*:

5.9.1 Warning labels, whether paper or nonpaper, shall be permanent when tested in accordance with 7.3.1 – 7.3.4.

5.9.2 Warning statements applied directly onto the surface of the product by hot stamping, heat transfer, printing, wood burning, etc. shall be permanent when tested in accordance with 7.3.1 and 7.3.5.

5.9.3 Nonpaper labels shall not liberate small parts when tested in accordance with 7.3.6.

5.10 *Compliance of Multi-use Products*—For an infant bath tub accessory that is also intended to be used separately as a standalone product covered under the scope of another ASTM or other standard, it shall also comply with the applicable requirements of that standard.

## 6. Performance Requirements

6.1 *Restraint System*—Products may have a permanent or removable passive crotch restraint as part of their design. They shall not have any additional restraint system(s) which requires action on the part of the caregiver to secure or release the restraint.

6.2 *Static Load*—The infant bath tub shall not break, become permanently deformed or damaged, or fail to comply with any of the other requirements of this consumer safety specification when tested in accordance with 7.4.

6.3 *Specific Requirements for Suction Cups*—Infant bath tubs that utilize individual suction cups as a method of attachment to a surface shall comply with the following requirements:

6.3.1 Each suction cup shall remain attached to the product and shall not become damaged or broken after testing in accordance with 7.5.1.

6.3.2 The product shall remain attached to the test surface and shall not become damaged or broken after testing in accordance with 7.5.2.

6.4 *Structural Integrity/Attachment of Infant Bath Tub Accessories*:

6.4.1 Tests required in this section for static and dynamic load shall be conducted in the sequence listed and using the same tub sample as in 6.2, unless the tub sample is damaged beyond use during testing, in which case a new tub sample shall be used to complete the testing.

6.4.2 Testing shall be conducted in each of the manufacturer's recommended use position(s) and for each separate mode of use recommended for the accessory.

6.4.3 *Static and Dynamic Load*—Accessories shall not allow any of the following conditions after being tested in accordance with 7.4.1 and 7.6.1 for static load and 7.6.2 for dynamic load:

6.4.3.1 Any parts of the accessory to become separated from it,

6.4.3.2 Any permanent damage,

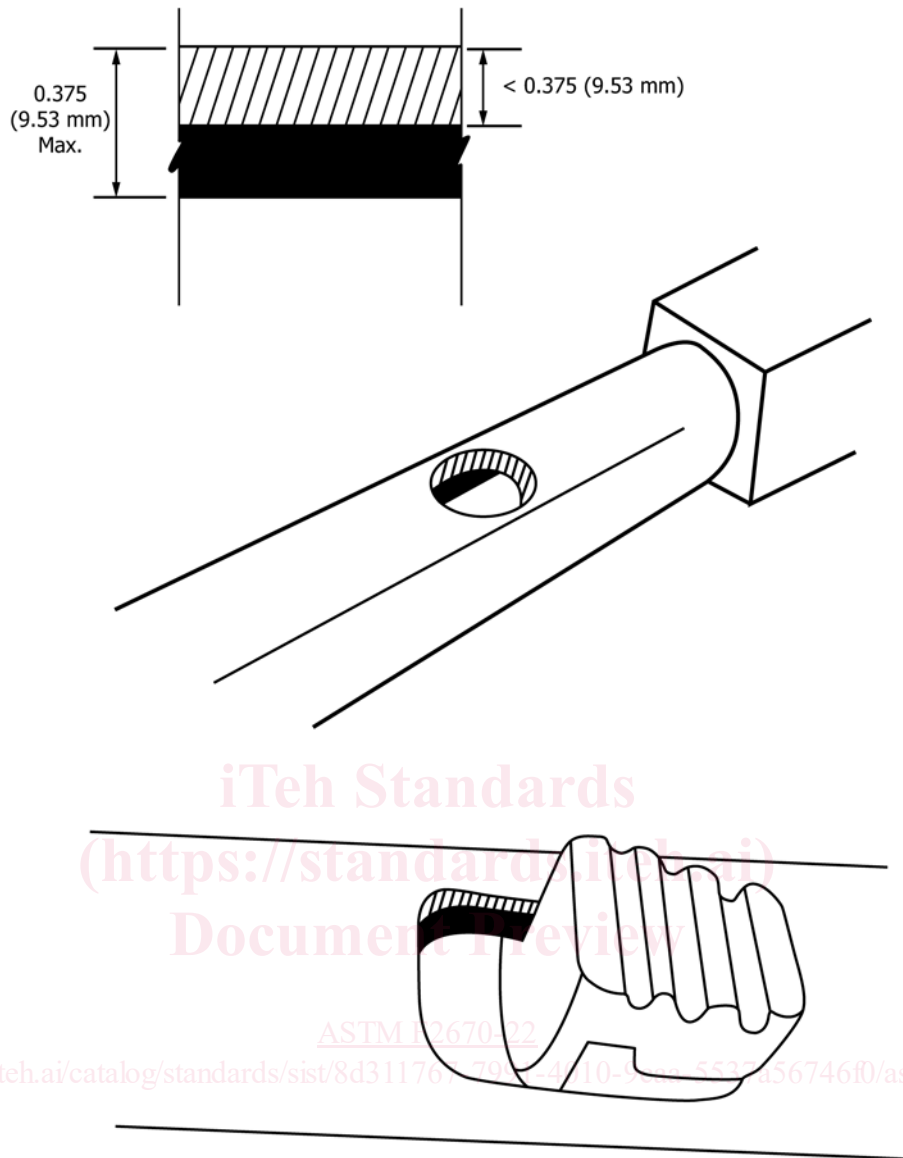

FIG. 1 Opening Examples

6.4.3.3 The accessory to collapse or any attachment point to disengage from (no longer be in contact with) the infant bath tub,

6.4.3.4 A change in adjustment that causes the infant bath tub accessory to not fully support the occupant,

6.4.3.5 The creation of a hazardous condition as defined in Section 5.

6.4.4 *Fabric/Mesh Integrity of Accessories*—Accessories shall meet the requirements of 6.4.4.1 and 6.4.4.2. At the conclusion of testing required by 6.4.4.1 and 6.4.4.2, there shall be no failure of seams, breakage of material, or change in adjustment that causes the infant bath tub accessory to not fully support the occupant or to create a hazardous condition as defined in Section 5.

6.4.4.1 *Seam Strength of Accessories*—All seams supporting the weight of the occupant, when tested in accordance with Test Method D1683/D1683M, shall have a breaking strength of 30 lbf (134 N) or greater.

6.4.4.2 *Mesh/Fabric Attachment Strength of Accessories*—When tested in accordance with 7.7, all locations on the accessory where a mesh or fabric assembly is mechanically fastened to a rigid structural element (for example, fastening of the assembly to a wire frame) shall not disengage or detach.

## 7. Test Methods

### 7.1 Latching and Locking Mechanism(s):

7.1.1 *Single-action Release Mechanism*—With the product in each manufacturer's recommended use position, gradually apply a 10-lbf (45-N) force to the latching and locking mechanism(s) in the direction tending to release it.

7.1.2 *Latching and Locking Mechanism Durability*—The latching and locking mechanism(s) shall be cycled through their normal operation for the number of cycles specified in 7.1.2.1 and 7.1.2.2. Each cycle shall consist of opening and closing the mechanism and erecting/folding the product. Cycling shall be conducted at continuous basis.

- 7.1.2.1 For infant bath tubs, use 2000 cycles.
- 7.1.2.2 For accessories, use 730 cycles.

7.2 *Removal of Protective Components Test:*

7.2.1 Prior to conducting the following tests, first completely submerge the testable components for 20 min in clear water that is at an initial temperature of 100 °F to 105 °F (37.8 °C to 40.6 °C). Conduct the following tests within 10 min after removal from the water.

7.2.2 Any protective component shall be tested in accordance with each of the following methods in the sequence listed.

7.2.3 Secure the product so that the product cannot move during the performance of the following tests:

7.2.4 *Torque Test*—Gradually apply a torque of 4 lbf-in. (0.4 N-m) over a period of 5 s in a clockwise direction until a rotation of 180° from the original position has been attained or 4 lbf-in. has been exceeded. The torque or maximum rotation shall be maintained for an additional 10 s. The torque shall then be removed and the test components permitted to return to a relaxed condition. This procedure shall then be repeated in the counter-clockwise direction.

7.2.5 *Tension Test:*

7.2.5.1 Attach a force gauge to the protective component by means of any suitable device. For components that cannot reasonably be expected to be grasped between thumb and forefinger, or teeth, on their outer diameter but have a gap of

0.04 in. (1.0 mm) or more between the rear surface of the component and the structural member of the product to which they are attached, a clamp such as shown in Fig. 2 may be a suitable device.

7.2.5.2 Be sure that the attachment device does not compress or expand the component hindering any possible removal.

7.2.5.3 Gradually apply a force of 15 lbf (67 N) over a period of 5 s in the direction that would normally be associated with the removal of the protective component. Hold for an additional 10 s.

7.3 *Permanence of Labels and Warnings:*

7.3.1 To determine the permanence of a label or printing applied to the surface of the product, first completely submerge the label or printed area for 20 min in clear water that is at an initial temperature of 100 °F to 105 °F (37.8 °C to 40.6 °C). Drain off the excess water and let the label or printed area air dry for 24 h at 73 °F ± 9 °F (23 °C ± 5 °C), 20 % to 70 % RH, prior to conducting any permanency tests.

7.3.2 A paper label (excluding labels attached by a seam) shall be considered permanent if, during an attempt to remove it without the aid of tools or solvents, it cannot be removed, it tears into pieces upon removal or such action damages the surface to which it is attached.

7.3.3 A nonpaper label (excluding labels attached by a seam) shall be considered permanent if, during an attempt to

(<https://standards.iteh.ai>)  
 Document Preview

15 lb Max TENSION

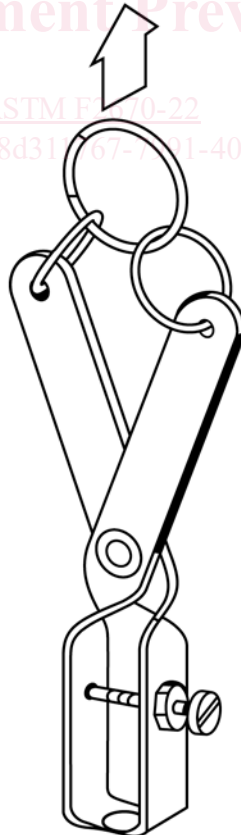

FIG. 2 Tension Test Adapter/Clamp

remove it without the aid of tools or solvents, it cannot be removed or such action damages the surface to which it is attached.

7.3.4 A warning label attached by a seam shall be considered permanent if it does not detach when subjected to a 15-lbf (67-N) pull force applied in any direction using a 3/4-in. diameter clamp surface.

7.3.5 Adhesion test for warnings applied directly onto the surface of the product.

7.3.5.1 Apply the tape test defined in Test Method B, Cross-Cut Tape Test of Test Methods **D3359**, eliminating parallel cuts.

7.3.5.2 Perform this test once in each different location where warnings are applied.

7.3.5.3 The warning statements will be considered permanent if the printing in the area tested is still legible and attached after being subjected to this test.

7.3.6 A nonpaper label, during an attempt to remove it without the aid of tools or solvents, shall not be removed or shall not fit entirely within the small parts cylinder defined in 16 CFR 1501 if it can be removed.

#### 7.4 *Static Load Test – Infant Bath Tub:*

7.4.1 Install the infant bath tub according to the manufacturer's instructions onto a smooth test surface. In the case where the product must be supported on or near its ends, use an appropriate support structure to simulate this support.

7.4.2 Place a load on the center of the seating surface using a 6 in. to 8 in. (150 mm to 200 mm) diameter bag filled with steel shot which has a total weight of 50 lb (22.7 kg) or three times the maximum weight of the child recommended by the manufacturer, whichever is greater.

7.4.3 Remove the weight after 20 minutes.

#### 7.5 *Suction Cup Tests:*

##### 7.5.1 *Suction Cup Attachment to Infant Bath Tub:*

7.5.1.1 If the product can be used inside another enclosure that may contain water (for example, a sink or an adult bath tub), then install the product according to the manufacturer's instructions onto the smooth test surface that is located inside a suitable enclosure that can be filled with water. Flood this outer enclosure, but not the infant bath tub itself, with clear water that is at an initial temperature of 100 °F to 105 °F (37.8 °C to 40.6 °C) to a depth of 2 in. (51 mm) above the highest point of the product occupant seating surface. Allow the product to soak for a minimum of 20 min.

7.5.1.2 Remove the product according to the manufacturer's instructions and immediately apply to each suction cup a tensile force of 25 lbf (111 N). Apply this force within 5 s and in the direction most likely to cause failure. Hold the force for an additional 10 s.

7.5.1.3 If the product cannot be used inside such other enclosure, install the product according to the manufacturer's instructions onto the smooth test surface, immediately remove it according to the manufacturer's instructions, and then perform the test in **7.5.1.2** without using the water soak.

##### 7.5.2 *Suction Cup Attachment to Surfaces:*

7.5.2.1 If the product can be used inside another enclosure that may contain water (for example, a sink or an adult bath tub), then install the product according to the manufacturer's

instructions onto the smooth test surface that is located inside a suitable enclosure that can be filled with water. Flood this outer enclosure, but not the infant bath tub itself, with clear water that is at an initial temperature of 100 °F to 105 °F (37.8 °C to 40.6 °C) to a depth of 2 in. (51 mm) above the highest point of the product occupant seating surface. Allow the product to soak for a minimum of 20 min.

7.5.2.2 Within 5 s, apply a vertical pull force of 25 lbf (111 N) at the center of the product. Hold the force for an additional 10 s.

7.5.2.3 Remove and install the product into the manufacturer's recommended use position(s) a total of 2000 cycles using the manufacturer's recommended method(s).

7.5.2.4 Repeat the testing specified in **7.5.2.2**.

7.5.2.5 If the product cannot be used inside such other enclosure, install the product according to the manufacturer's instructions onto the smooth test surface, and then perform the tests in **7.5.2.2 – 7.5.2.4** without using the water soak.

#### 7.6 *Structural Integrity – Infant Bath Tub Accessory:*

##### 7.6.1 *Static Load Test:*

7.6.1.1 Position accessory in/on tub according to the manufacturer's instructions.

7.6.1.2 Place a load on the accessory using a 6 in. to 8 in. (150 mm to 200 mm) diameter bag filled with steel shot which has a total weight of 50 lb (22.7 kg) or three times the maximum weight of the occupant recommended by the manufacturer, whichever is greater. The load shall be located at the seat bight line (refer to **Fig. 3**).

7.6.1.3 Remove the weight after 20 min.

##### 7.6.2 *Dynamic Load Test:*

7.6.2.1 Position accessory in/on tub according to the manufacturer's instructions.

7.6.2.2 Place a load on the accessory using a 6 in. to 8 in. (150 mm to 200 mm) diameter bag filled with steel shot which has a total weight of 18 lb (8.2 kg). The load shall be located at the seat bight line (refer to **Fig. 3**). Raise the shot bag a distance of 1 in. (25 mm) and drop the weight onto the accessory. Repeat for a total of 50 cycles with a cycle time of  $4 \pm 1$  s/cycle. The drop height is to be adjusted to maintain the 1 in. (25 mm) drop height as is practical.

##### 7.7 *Mesh/Fabric Attachment Strength Test Method:*

7.7.1 Gradually apply a force of 30 lbf (130 N) using a clamp with a 3/4 in. (19 mm) diameter clamping surface to one attachment point in the most onerous direction that represents the force due to the weight of the occupant. Gradually apply the force over 5 s and hold for an additional 10 s.

7.7.2 Repeat the test in **7.7.1** for all attachment points.

## 8. Marking and Labeling

8.1 Each product and its retail package shall be marked or labeled clearly and legibly to indicate the following:

8.1.1 The name, place of business (city, state, and mailing address, including zip code), and telephone number of the manufacturer, distributor, or seller.

8.1.2 A code mark or other means that identifies the date (month and year at a minimum) of manufacture.

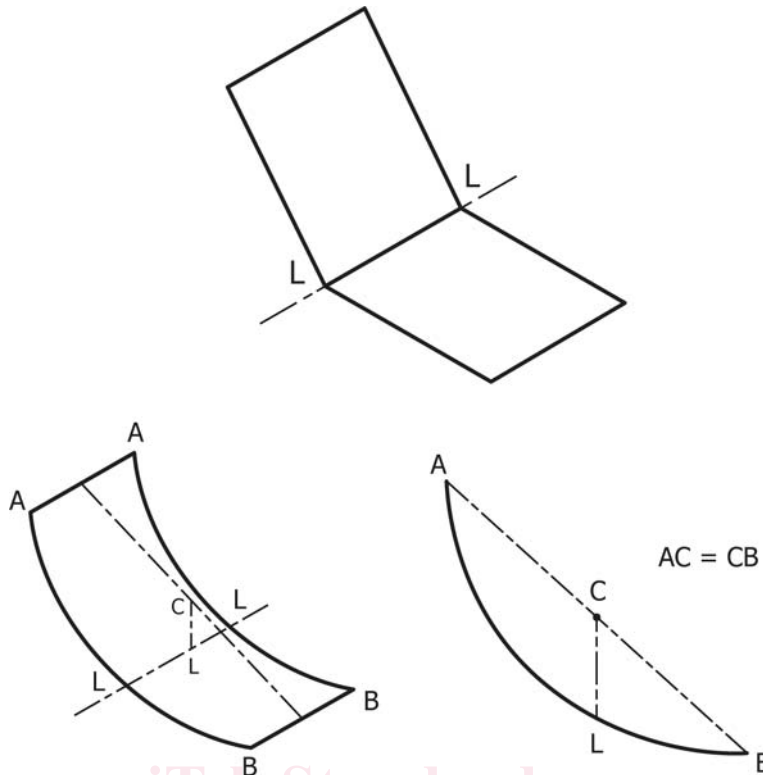

LL = Seat Bight Line  
 CL = Vertical Projection of C on the Seat

When the seat does not have a defined intersection of the seat bottom and seat back, then a theoretical bight line, “LL,” is determined as shown. The bight line will vary with products that have adjustable backrests.

FIG. 3 Seat Bight Location—Intersection of Seat Bottom and Seat Back

8.2 The marking and labeling on the product shall be permanent.

8.3 Any upholstery labeling required by law shall not be used to meet the requirements of this section.

8.4 *Battery-operated Product Marking:*

8.4.1 Each product’s battery compartment, battery compartment door/cover, or area immediately adjacent to the battery compartment shall be marked or labeled permanently and legibly to show the correct battery polarity, size, and voltage. These markings are not required for products utilizing one or more non-replaceable batteries.

8.4.2 Products utilizing one or more non-replaceable batteries accessible with the use of a coin, screwdriver, or other common household tool shall be marked or labeled permanently and legibly with a statement that the batteries are not replaceable. If marking or labeling the product is not practicable, then this statement shall be in the instructions.

8.5 *Warning Design for Product:*

8.5.1 The warnings shall be easy to read and understand and be in the English language at a minimum.

8.5.2 Any marking or labeling provided in addition to those required by this section shall not contradict or confuse the meaning of the required information, or be otherwise misleading to the consumer.

8.5.3 The warnings shall be conspicuous and permanent.

8.5.4 The warnings shall conform to ANSI Z535.4–2011, sections 6.1 – 6.4, 7.2 – 7.6.3, and 8.1, with the following changes.

8.5.4.1 In sections 6.2.2, 7.3, 7.5, and 8.1.2, replace “should” with “shall.”

8.5.4.2 In section 7.6.3, replace “should (when feasible)” with “shall.”

8.5.4.3 Strike the word “safety” when used immediately before a color (for example, replace “safety white” with “white”).

NOTE 2—For reference, ANSI Z535.1 provides a system for specifying safety colors.

8.5.5 The safety alert symbol “ $\Delta$ ” and the signal word “**WARNING**” shall be at least 0.2 in. (5 mm) high and in bold capital letters. The remainder of the text shall be in characters whose upper case shall be at least 0.1 in. (2.5 mm) high, except where otherwise specified.

NOTE 3—For improved warning readability, typefaces with large height-to-width ratios, which are commonly identified as “condensed,” “compressed,” “narrow,” or similar should be avoided.

8.5.6 *Message Panel Text Layout:*

8.5.6.1 The text shall be left-aligned, ragged-right for all but one-line text messages, which can be left-aligned or centered.

NOTE 4—Left-aligned means that the text is aligned along the left