



Designation: E3024/E3024M – 22a

Standard Practice for Magnetic Particle Testing for General Industry¹

This standard is issued under the fixed designation E3024/E3024M; the number immediately following the designation indicates the year of original adoption or, in the case of revision, the year of last revision. A number in parentheses indicates the year of last reapproval. A superscript epsilon (ϵ) indicates an editorial change since the last revision or reapproval.

1. Scope*

1.1 This practice establishes minimum requirements for magnetic particle testing used for the detection of surface or slightly subsurface discontinuities in ferromagnetic material. This practice is intended for industrial applications. Refer to Practice E1444/E1444M for aerospace applications. Guide E709 may be used in conjunction with this practice as a tutorial.

1.2 The magnetic particle testing method is used to detect cracks, laps, seams, inclusions, and other discontinuities on or near the surface of ferromagnetic materials. Magnetic particle testing may be applied to raw material, billets, finished and semi-finished materials, welds, and in-service parts. Magnetic particle testing is not applicable to non-ferromagnetic metals and alloys such as austenitic stainless steels. See Appendix XI for additional information.

1.3 All areas of this practice may be open to agreement between the Level III or the cognizant engineering organization, as applicable, and the supplier.

1.4 *Units*—The values stated in either SI units or inch-pound units are to be regarded separately as standard. The values stated in each system are not necessarily exact equivalents; therefore, to ensure conformance with the standard, each system shall be used independently of the other, and values from the two systems shall not be combined.

1.4.1 This standard is a combined standard, an ASTM standard in which rationalized SI units and inch-pound units are included in the same standard, with each system of units to be regarded separately as standard.

1.5 *This standard does not purport to address all of the safety concerns, if any, associated with its use. It is the responsibility of the user of this standard to establish appropriate safety, health, and environmental practices and determine the applicability of regulatory limitations prior to use.*

1.6 *This international standard was developed in accordance with internationally recognized principles on standard-*

ization established in the Decision on Principles for the Development of International Standards, Guides and Recommendations issued by the World Trade Organization Technical Barriers to Trade (TBT) Committee.

2. Referenced Documents

2.1 The following documents form a part of this practice to the extent specified herein.

2.2 *ASTM Standards*:²

E543 Specification for Agencies Performing Nondestructive Testing

E709 Guide for Magnetic Particle Testing

E1316 Terminology for Nondestructive Examinations

E1444/E1444M Practice for Magnetic Particle Testing for Aerospace

E2297 Guide for Use of UV-A and Visible Light Sources and Meters used in the Liquid Penetrant and Magnetic Particle Methods

E3022 Practice for Measurement of Emission Characteristics and Requirements for LED UV-A Lamps Used in Fluorescent Penetrant and Magnetic Particle Testing

2.3 *ASNT Documents*:³

SNT-TC-1A Recommended Practice for Personnel Qualification and Certification in Nondestructive Testing

ANSI/ASNT CP-189 Standard for Qualification and Certification of Nondestructive Testing Personnel

2.4 *SAE-AMS Documents*:^{4,5}

AMS 2641 Magnetic Particle Inspection Vehicle

AMS 3040 Magnetic Particles, Nonfluorescent, Dry Method

AMS 3041 Magnetic Particles, Nonfluorescent, Wet Method, Oil Vehicle, Ready-To-Use

AMS 3042 Magnetic Particles, Nonfluorescent, Wet Method, Dry Powder

² For referenced ASTM standards, visit the ASTM website, www.astm.org, or contact ASTM Customer Service at service@astm.org. For *Annual Book of ASTM Standards* volume information, refer to the standard's Document Summary page on the ASTM website.

³ Available from American Society for Nondestructive Testing (ASNT), P.O. Box 28518, 1711 Arlingate Ln., Columbus, OH 43228-0518, <http://www.asnt.org>.

⁴ Available from SAE International (SAE), 400 Commonwealth Dr., Warrendale, PA 15096, <http://www.sae.org>.

⁵ Copies of standards, specifications, drawings, and publications required by manufacturers in connection with specification acquisition should be obtained from the contracting activity or as directed by the contracting officer.

¹ This practice is under the jurisdiction of ASTM Committee E07 on Nondestructive Testing and is the direct responsibility of Subcommittee E07.03 on Liquid Penetrant and Magnetic Particle Methods.

Current edition approved March 15, 2022. Published March 2022. Originally approved in 2016. Last previous edition approved in 2022 as E3024/E3024M – 22. DOI: 10.1520/E3024_E3024M-22A.

*A Summary of Changes section appears at the end of this standard

[AMS 3043 Magnetic Particles, Nonfluorescent, Wet Method, Oil Vehicle, Aerosol Packaged](#)
[AMS 3044 Magnetic Particles, Fluorescent, Wet Method, Dry Powder](#)
[AMS 3045 Magnetic Particles, Fluorescent, Wet Method, Oil Vehicle, Ready-To-Use](#)
[AMS 3046 Magnetic Particles, Fluorescent, Wet Method, Oil Vehicle, Aerosol Packaged](#)
[AMS 5062 Steel, Low Carbon Bars, Forgings, Tubing, Sheet, Strip, and Plate 0.25 Carbon, Maximum](#)
[AMS I-83387 Inspection Process, Magnetic Rubber](#)
[AS 4792 Water Conditioning Agents for Aqueous Magnetic Particle Inspection](#)
[AS 5371 Reference Standards Notched Shims for Magnetic Particle Inspection](#)

2.5 *Federal Standard*:^{5,6}

[FED-STD-313 Material Safety Data Sheets, Preparation and the Submission of](#)

2.6 *Military Standard*:^{5,7}

[A-A-59230 Fluid, Magnetic Particle Inspection, Suspension](#)

2.7 *OSHA Document*:^{5,8}

[29 CFR 1910.1200 Hazard Communication](#)

2.8 *ISO Documents*:^{5,9}

[ISO 7810 Identification Cards—Physical Characteristics](#)

[ISO 9712 Nondestructive Testing—Qualification and Certification of NDT Personnel](#)

[ISO 10012 Measurement Management Systems—Requirements for Measurement Processes and Measuring Equipment](#)

2.9 *ANSI Documents*:¹⁰

[ANSI/NCSL Z540.1 Calibration Laboratories and Measuring Test Equipment – General Requirements](#)

[ANSI/NCSL Z540.3 General Requirement for Calibration Laboratories and Measuring Test Equipment](#)

2.10 *Order of Precedence*—In the event of conflict between the text of this practice and the referenced documents cited herein, the text of this practice takes precedence.

3. Terminology

3.1 *Definitions*—The definitions relating to magnetic particle testing, which appear in Terminology [E1316](#), shall apply to the terms used in this practice.

3.2 *Definitions of Terms Specific to This Standard*:

3.2.1 *magnetometer, n*—mechanical instrument used to measure magnetic field strength, in air, adjacent to the part.

⁶ Available from U.S. Government Printing Office Superintendent of Documents, 732 N. Capitol St., NW, Mail Stop: SDE, Washington, DC 20401, <http://www.access.gpo.gov>.

⁷ Available from Standardization Documents Order Desk, DODSSP, Bldg. 4, Section D, 700 Robbins Ave., Philadelphia, PA 19111-5098, <http://dodssp.daps.dla.mil>.

⁸ Available from U.S. Government Printing Office Superintendent of Documents, 732 N. Capitol St., NW, Mail Stop: SDE, Washington, DC 20401, <http://www.access.gpo.gov>.

⁹ Available from International Organization for Standardization (ISO), ISO Central Secretariat, BIBC II, Chemin de Blandonnet 8, CP 401, 1214 Vernier, Geneva, Switzerland, <http://www.iso.org>.

¹⁰ Available from National Conference of Standards Laboratories, 1800 30th St., Suite 305b, Boulder, CO, 80301.

4. Significance and Use

4.1 *Description of Process*—Magnetic particle testing consists of magnetizing the area to be examined, applying suitably prepared magnetic particles while the area is magnetized, and subsequently interpreting and evaluating any resulting particle accumulations. Maximum detectability occurs when the discontinuity is positioned on the surface and perpendicular to the direction of magnetic flux in the part.

4.2 This practice establishes the basic parameters for controlling the application of the magnetic particle testing method. This practice is written so that it can be specified on the engineering drawing, specification, or contract. It is not a detailed how-to procedure to be used by the examination personnel and, therefore, must be supplemented by a detailed written procedure that conforms to the requirements of this practice.

5. General Practice

5.1 *Personnel Qualification*—Personnel performing examinations in accordance with this practice shall be qualified and certified in accordance with ASNT Recommended Practice No. SNT-TC-1A, ANSI/ASNT Standard CP-189, ISO 9712, or as specified in the contract or purchase order.

5.2 *Agency Qualification*—If specified in the contractual agreement, NDT agencies shall be qualified and evaluated as described in Specification [E543](#). The applicable edition of Specification [E543](#) shall be specified in the contractual agreement.

5.3 *Written Procedure*—Magnetic particle testing shall be performed in accordance with a written procedure applicable to the part or group of parts under examination. The procedure shall be in accordance with the requirements of this practice. The process, when conducted in accordance with the written procedure, shall be capable of detecting discontinuities specified in the acceptance criteria. The written procedure may be general if it clearly applies to all of the specified parts being examined and meets the requirements of this practice. All written procedures, including technique sheets for specific parts, shall be approved by an individual qualified and certified at Level III for magnetic particle testing in accordance with the requirements of [5.1](#). When applicable, procedures shall be submitted to the cognizant engineering organization for review, or approval, or both, when requested.

5.3.1 *Elements of the Written Procedure*—The written procedure shall include at least the following elements, either directly or by reference to the applicable documents:

5.3.1.1 Procedure identification number and the date it was written;

5.3.1.2 Identification of the part(s) to which the procedure applies; this shall include the material or alloy, or both;

5.3.1.3 For new components, sequence of magnetic particle testing as related to manufacturing process operation (for example, post-plating, after heat treat, etc.);

5.3.1.4 Identification of test parts used for system performance verification (see [7.1.1](#) and [7.1.2](#));

5.3.1.5 Process controls (see [Table 1](#)); including the definition of “use” in [7.3.2.2](#) and [7.4.4](#);

TABLE 1 Process Control and Calibration

Item	Maximum Time Between Verification ^A	Paragraph
Lighting ^B		
Visible light intensity	Weekly	7.3.1.1, 7.3.1.2
Ambient visible light intensity	Weekly	7.3.1.2
UV-A lamp intensity	Daily	7.3.2, 7.4.5
Battery powered UV-A lamp intensity check	Prior to and after each use	7.3.2.2
UV-A lamp integrity ^C	Daily	7.3.2
System Performance ^B	Daily	7.1.7.1.1, 7.1.2
Wet particle concentration	8 hours, or every shift change	7.2.1.1
Wet particle contamination ^B	1 week	7.2.1.2
Water break test	Daily	7.2.2
Equipment calibration check: ^B		
Ammeter accuracy	6 months	7.4.1
Timer control	6 months	7.4.2
Quick break	6 months	7.4.3
Yoke dead weight check	6 months	7.4.4
Yoke dead weight check (battery-powered)	Before and after each use	7.4.4
UV-A radiometer and visible light photometer	6 months	7.4.7
Hall-Effect Gaussmeter accuracy	12 months	7.4.6
Magnetometer (Field Indicator) accuracy	6 months	7.4.6

^A When the test system is in operation.

^B The maximum time between verifications may be reduced or extended when substantiated by actual technical/reliability data.

^C Need not be recorded.

5.3.1.6 Areas of the part to be examined and where appropriate, identified by a photograph, sketch, or relationship to a drawing, etc., to show the area;

5.3.1.7 Part preparation required before examination;

5.3.1.8 Directions for positioning the item with respect to the magnetizing equipment;

5.3.1.9 The type of magnetizing current and the equipment to be used;

5.3.1.10 Method of establishing the magnetization (internal conductor, head, coil, prods, yoke, cable wrap, etc.);

5.3.1.11 Directions of magnetization to be used, the order in which they are applied, and any demagnetization procedures to be used between field applications;

5.3.1.12 The current level, or the number of ampere turns, to be used and the duration of its application or a procedure for establishing proper magnetization;

5.3.1.13 Type of magnetic particle material (dry or wet, visible or fluorescent, etc.) to be used and the method and equipment to be used for its application and, for the case of wet particles, the particle concentration limits;

5.3.1.14 Type of records and method of marking parts after examination;

5.3.1.15 Acceptance requirements, to be used for evaluating indications and disposition of parts after evaluation; and

5.3.1.16 Post-examination demagnetization and cleaning requirements.

5.3.1.17 The method and measurement frequency will be defined for meeting the minimum examination intensity for all UV-A lamps, including battery-powered lamps. Any requirements for documentation of the measurements will also be defined.

5.4 *Examination Sequence*—Perform magnetic particle examination after all operations which might cause or reveal discontinuities. Such operations include, but are not limited to, forging, heat treating, electroplating, forming, welding, grinding, straightening, machining, and proof loading.

5.4.1 Unless otherwise specified in the contract or part drawing, magnetic particle examination shall be performed prior to shot peening and prior to applying protective finishes such as priming, painting, plating (see 5.4.3 through 5.4.3.2), or other coatings.

5.4.2 In-process examinations may not be substituted for final examination.

5.4.3 *Plating and Coatings*—The written procedure shall specify any limitations or other requirements associated with plating or coatings.

5.4.3.1 Use caution when examining parts with an electroplated nickel coating as indications may form from the resulting leakage fields within the nickel plating itself.

5.4.3.2 For in-service examination, plating or coatings do not require removal prior to examination unless they are damaged or they interfere with the examination process.

NOTE 1—Examination sensitivity decreases as plating/coating thickness increases.

5.5 *Materials:*

5.5.1 *Dry Particle Requirements*—Dry particles shall meet the requirements of AMS 3040.

5.5.2 *Wet Particle Requirements*—Wet particles shall meet the requirements of AMS 3041, 3042, 3043, 3044, 3045, or 3046, as applicable.

5.5.2.1 *Dual Response*—Dual response particles are detectable in visible light and also display fluorescence when viewed under UV-A or a combination of visible and UV-A light. Use in accordance with the manufacturer's recommendations.

5.5.2.2 *White Background and Black Oxide*—A thin white background is applied by aerosol to provide a thin (≤ 2 mil), smooth, high contrast background prior to magnetization and particle application. After background has dried, magnetization and particle application follow normal procedures. The high contrast between the white background and black particles provides high sensitivity in visible light conditions. Detailed

application and use instructions of the manufacturer shall be followed for optimum results.

5.5.3 Suspension Vehicles—The suspension vehicle for the wet method shall be a light petroleum distillate conforming to AMS 2641 (Type I) or A-A-59230, or a suitably conditioned water that conforms to the requirements of 5.5.4. When approved by the Level III or the cognizant engineering organization, as applicable, AMS 2641 (Type II) may be used. When specified, the oil suspension vehicle shall meet the salient characteristics specified in A-A-59230.

5.5.4 Conditioned Water Vehicle—When water is used as a suspension vehicle for magnetic particles, the conditioning agents used shall comply with AS 4792. Proper wetting shall be determined by a water break test (see 7.2.2). Smoother surfaces generally require a greater percent of wetting agent than rough surfaces. Foaming of the bath must be minimized to the point that it does not interfere with the examination process.

5.5.4.1 Water Vehicle Conditioning Agents—Any agents added to the water vehicle for any purpose shall conform to the requirements of the particle manufacturer.

5.5.5 Particle Concentration—The concentration of particles in the suspension bath shall be as specified in the written procedure. Particle concentrations outside of the range of 0.1 to 0.4 mL in a 100 mL bath sample for fluorescent particles and 1.2 to 2.4 mL in a 100 mL sample for nonfluorescent particles shall not be used. Fluorescent particles and nonfluorescent particles shall not be used together.

5.5.5.1 The concentration of dual response particles in the wet-method bath suspension shall be adjusted to best perform in the desired lighting environment. Higher particle concentration is used for visible light areas and lower particle concentration is used for UV-A areas. Use in accordance with the particle manufacturer's recommendations.

5.6 Safety—The safe handling of magnetic particles (wet or dry), oil vehicles, water baths, and water conditioner concentrates are governed by the suppliers' Safety Data Sheets (SDS). SDS, conforming to 29 CFR 1910.1200, or equivalent, must be provided by the supplier to any user and shall be prepared in accordance with FED-STD-313.

5.6.1 Flammability—Flash point of oil vehicles shall be in accordance with AMS 2641, Type I carriers. The suppliers' SDS shall certify the flash point.

5.6.2 Personnel Hazards—Precautions against inhalation, skin contact, and eye exposure are detailed in the suppliers' SDS. These precautions shall be observed.

5.6.3 Electrical Hazards—Magnetizing equipment shall be maintained properly to prevent personnel hazards from electrical short circuits. Care must be taken to reduce arcing and the possible ignition of oil baths.

5.6.4 UV-A Lamps—Replace cracked or broken ultraviolet filters immediately. Broken filters can allow harmful ultraviolet energy to be emitted and must be replaced immediately. Spectacles designed to absorb ultraviolet energy are suggested for close, high-intensity UV-A light examination. LED UV-A lamps used for evaluation purposes shall comply with Practice E3022. See 7.3.2.

6. Specific Practice

6.1 Preparation of Parts for Testing

6.1.1 Pre-examination Demagnetization—The part shall be demagnetized before testing if prior operations have produced a residual magnetic field that may interfere with the examination.

6.1.2 Surface Cleanliness and Finish—The surface of the part to be examined shall be essentially smooth, clean, dry, and free of oil, scale, machining marks, or other contaminants or conditions that might interfere with the efficiency of the examination.

6.1.3 Plugging and Masking—Plugging and masking is required when specified.

6.1.4 All areas on the part where electrical contact is made shall be sufficiently clean to prevent electrical arcing.

6.2 Magnetization Methods:

6.2.1 Types of Magnetizing Current—The types of currents used for magnetic particle testing are full-wave rectified current (1 or 3 phase), half-wave rectified current, alternating current, direct current, and capacitor discharge current. The equipment used shall fulfill the magnetizing and demagnetizing requirements adequately, as outlined herein, without damage to the part under examination, and they shall include the necessary features required for safe operation.

6.2.2 Permanent Magnets—Permanent magnets may be used when approved by the Level III or the cognizant engineering organization, as applicable, and when a technique has been developed and approved.

6.2.3 Yokes—When using yokes (electromagnetic probes) for magnetic particle testing, they shall meet the requirements of 7.4.4.

6.2.3.1 When using yokes, the pole pieces shall be positioned in contact with the part surface as flat as possible.

6.2.3.2 Yoke leg positioning shall include overlapping shots with consideration for the banding effects at the leg/pole contact points.

6.2.3.3 When examining localized areas on parts with complicated geometries, leg spacing shall include consideration for both field direction and banding effects.

6.2.3.4 When using portable equipment that is not timer controlled, any examination that does not have the magnetizing power on during both particle application and excess particle removal is considered a residual examination.

6.2.3.5 For weld examinations, one yoke orientation shall be approximately perpendicular to the weld with the second orientation set parallel to the weld.

6.2.3.6 Battery powered DC yokes may be used when approved by the Level III and when a technique has been developed and approved.

(1) The technique must be validated for material thickness greater than $\frac{3}{8}$ in. [9.5 mm].

(2) Battery powered yokes may not show all surface indications for all thicknesses of material, even though the requirements in 7.4.4 have been met or the field strength has been indicated on a shim, or both.

NOTE 2—Use of dry magnetic particles for surface indications is not recommended when using battery powered DC yokes.

6.2.4 *Magnetizing Current Application*—Full-wave rectified current has the deepest penetration and should be used for examination of sub-surface discontinuities when using the wet magnetic particle method. Half-wave rectified current may also be used for examination of sub-surface discontinuities and due to the pulsating nature of the waveform, it has the advantage of increased particle mobility. Alternating current is to be only used for the detection of discontinuities open to the surface.

6.2.4.1 *Direct Current (DC)*—Direct Current is produced by banks of batteries, full-wave rectified AC, or a DC generator.

6.2.4.2 *Capacitor Discharge (CD) Current*—A bank of capacitors are used to store energy and when triggered the energy reaches high amperage with a very short duration (normally less than 25 milliseconds). Because of the short pulse duration, the current requirements are affected by the amount of material to be magnetized as well as the applied amperage. The capacitor discharge technique may be used to establish a residual magnetic field in tubing, casing, line pipe, and drill pipe. For specific requirements, see [Appendix X5](#).

6.2.5 *Magnetic Field Directions*—Discontinuities are difficult to detect by the magnetic particle method when they make an angle less than 45° to the direction of magnetization. To ensure the detection of discontinuities in any direction, each part must be magnetized in a minimum of two directions at approximately right angles to each other. Depending on part geometry, this may consist of circular magnetization in two or more directions, multiple circular and longitudinal magnetizations, or of longitudinal magnetization in two or more directions. The pie-field indicator as illustrated in Fig. X4.1, the flexible laminated strips as described in [Annex A3](#), or a properly prepared master part using notched shims may only be used as a tool to demonstrate the direction of the external magnetic field. The pie-field indicator or flexible laminated strips shall not be used to determine adequate field strength.

6.2.6 *Multidirectional Magnetization*—Multidirectional magnetization may be used to fulfill the requirement for magnetization in two or more directions if it is demonstrated that the technique is effective in all areas requiring examination. Examine parts in accordance with [6.3.1.1](#) or with shims manufactured to the requirements of AS 5371 ([Annex A2](#)), or as otherwise approved by the Level III or the cognizant engineering organization, as applicable. When used, the shims shall be used to verify field direction, strength, and balance in multidirectional magnetization. Balancing of the combined magnetic field is critical and an adequate balance must be visually demonstrated to be effective in all areas requiring examination. The particle application must be timed so that the magnetization levels reach full value in all directions while the particles are mobile on the surface under examination.

6.2.7 *Direct Magnetization*—Direct magnetization is accomplished by passing current directly through the part under examination. Electrical contact is made to the part using head and tail stock, prods, clamps, magnetic leeches, or by other means. Caution shall be taken to ensure that the electrical current is not flowing while contacts are being applied or removed and that excessive heating does not occur in any area of the part. Prods shall not be used for the examination of finished surfaces.

6.2.8 *Indirect Magnetization*—Indirect part magnetization uses pre-formed coils, cable wraps, yokes, field (flux) flow fixtures, or an internal conductor to induce a magnetic field in a part when no direct electrical contact is made.

6.2.9 *Induced Current Magnetization*—Induced current magnetization (toroidal or circumferential field) is accomplished by inductively coupling a part to an electrical coil in order to create a suitable current flow within the part as illustrated in Fig. X4.2. This method is often advantageous on ring-shaped parts with a central aperture and with an L/D ratio less than three, especially where the elimination of arcing or burning is of vital importance.

6.2.10 *Parallel Current Induced Magnetization*—This method of magnetization may occur when a ferromagnetic part is placed alongside and parallel to a current-carrying conductor. This type of magnetization shall only be used when approved by the Level III and when an approved technique has been developed for use on solid parts.

6.3 *Magnetic Field Strength:*

6.3.1 *Magnetic Field Strength*—The applied magnetic field shall have sufficient strength to produce satisfactory indications, but it must not be so strong that it causes the masking of relevant indications by nonrelevant accumulations of magnetic particles. Adequate magnetic field strength may be determined by one or a combination of the following methods.

6.3.1.1 In unidirectional or multidirectional magnetizing applications, by examining parts having known or artificial discontinuities of the type, size, and location specified in the acceptance requirements or by using the notched shims as defined in [Annex A1](#).

6.3.1.2 In unidirectional magnetizing applications only, by using an electronic gaussmeter capable of measuring the peak values of the tangential field as described in [Annex A4](#). Tangential-field strengths shall have a minimum value of 30 Gauss (30×10^{-4} Tesla [T]) when measured at the part surface using an electronic gaussmeter as described in [Annex A4](#). The maximum Gauss value derived is limited by the restrictions of [6.3.1](#).

6.3.1.3 For circular magnetization, the written procedure shall specify the amperage requirements for the specific part to be examined. If the requirements are unknown, the formulas in [Appendix X3](#) may be used as a starting point in developing the required amperage for specific parts.

6.3.1.4 For longitudinal magnetization, the written procedure shall specify the amp-turns, particle mobility characteristics, or external field strength requirements, or a combination thereof, for the specific part to be examined. If the requirements are unknown, the formulas in [Appendix X3](#) in [Guide E709](#) may be used as a starting point in developing the required amperage for specific parts. The current levels and formulas in [Guide E709](#) provide only a rough guide and shall only be used in conjunction with either [6.3.1.1](#), or [6.3.1.2](#). In some cases, these formulas may lead to over magnetization of the work piece and care should be exercised when using them.

6.3.2 *Longitudinal Magnetization Using Coils*—Longitudinal magnetization is often accomplished by passing current through a coil encircling the part, or section of the part, to be examined (that is, by using a coil shot). This produces a

magnetic field parallel to the axis of the coil. The actual effective distance must be demonstrated based on the particular part to be examined. For parts longer than these effective distances, the entire length shall be examined by repositioning the part within the coil, allowing for approximately 10 % effective magnetic field overlap. See 6.3.1 for field strength methods that can be used in coil magnetization.

6.3.3 *Magnetizing Current Shots*—In a series of magnetizing shots, unless there is an interim demagnetization operation, the amperage value shall proceed from a lower to a higher selection.

6.3.4 *Coil Shots*—The value of the coil shot expressed in ampere-turns (AT) is considered to be the current multiplied by the number of coil turns.

6.3.5 The specimen under examination shall have a minimum L/D ratio of 2 for proper coil magnetization.

6.4 *Particle Application*

6.4.1 *Dry Magnetic Particle Application, Continuous Method*—When using dry particles, the flow of magnetizing current shall be initiated prior to application of the magnetic particles to the surface under examination and terminated after particle application has been completed and any excess blown off. Precautions shall be taken to prevent any damage to the part due to overheating.

6.4.1.1 Apply dry powder so that a light, uniform, dust-like coating settles on the surface of the part under examination while the part is being magnetized. Specially designed powder blowers or shakers using compressed air or hand power shall be used. The applicators shall introduce the particles into the air in a manner such that they reach the part surface in a uniform cloud with a minimum of force.

6.4.1.2 After the powder is applied, and before the magnetizing force is removed, excess powder shall be removed, by means of a dry air current with sufficient force to remove the excess particles, if they interfere with interpretation and evaluation, but not strong enough to disturb particles held by a leakage field that is indicative of discontinuities. In order to recognize the broad, fuzzy, lightly held powder patterns formed by near-surface discontinuities, the formation of indications must be observed carefully during both powder application and removal of the excess powder.

6.4.1.3 Dry magnetic particles shall not be reused, unless a process for reclamation has been established and approved by the Level III.

6.4.2 *Wet Magnetic Particle Application, Continuous Method*—Fluorescent or nonfluorescent particles suspended in a liquid vehicle at the required concentration shall be applied by gently spraying or flowing the suspension over the area to be examined.

6.4.2.1 Proper sequencing and timing of part magnetization and application of particle suspension are required to obtain the proper formation and retention of indications. This requires that the stream of suspension be diverted from the part simultaneously with, or slightly before, energizing the magnetic circuit.

6.4.2.2 The magnetizing current shall be applied for a duration of at least 0.5 second for each application, with a

minimum of two shots being used. The second shot shall follow the first while the particles are still mobile on the surface of the part.

6.4.2.3 Under special circumstances, such as the use of automated equipment or for critical parts, the 0.5 second duration and the two-shot requirement may be waived provided it is demonstrated that the procedure can detect known discontinuities in reference parts.

6.4.2.4 Care shall be exercised to prevent any damage to the part due to overheating or other causes. Weakly held indications on highly finished parts are readily washed away, and care must be exercised to prevent high-velocity flow over critical surfaces. Surfaces to be examined shall not be handled or contacted until the examination is complete.

6.4.2.5 Particle application by continuous immersion shall be used only when it has been documented that it can detect discontinuities or artificial discontinuities in parts under examination.

6.4.3 *Residual Magnetization Method*—In the residual magnetization method, the magnetic particles (dry or wet) are applied to the part under examination after the magnetizing force has been discontinued. The residual method is not as sensitive as the continuous method. It can be useful on materials with high retentivity. When inducing circular fields and longitudinal fields in long pieces, residual fields are normally sufficient to meet magnetizing requirements consistent with the requirements of 7.1.1 or 7.1.2. The residual method has found wide use examining pipe and tubular goods. For magnetization requirements of oilfield tubulars, refer to Appendix X5. It is also useful for the examination of parts or areas of parts, which because of geometric constraints, cannot be examined with the continuous method. The residual method shall be used only when it has been documented that it can detect discontinuities or artificial discontinuities in parts under examination and when approved by the Level III or the cognizant engineering organization, as applicable. The test parts shall have the same material and processing steps, and similar geometry, to the actual parts being examined.

6.4.4 *Magnetic Slurry/Paint Application*—Magnetic paints or slurries are applied to the part with a brush, squeeze bottle, or aerosol can before or during the magnetization operation. This method is for special applications, such as overhead or underwater examination.

6.4.5 *Magnetic Polymer Application*—Polymerizable material containing magnetic particles shall be held in contact with the part under examination during the period of its cure. Before curing takes place, and while the magnetic particles are still mobile, the part shall be magnetized to the specified level. This requires prolonged or repeated periods of magnetization. This method is for special applications, such as bolt holes which cannot be examined readily by the wet or dry method. AMS-I-83387 establishes the examination process for magnetic rubber.

6.5 *Evaluation*—Following magnetization and particle application and before demagnetizing, the parts shall be examined for indications. All indications will be identified as relevant or nonrelevant. Relevant indications will be compared to the proper accept/reject criteria and the parts accepted or rejected accordingly.

6.5.1 *Eye Glasses*—When using fluorescent materials, personnel shall not wear eye glasses that are photochromic (transition lenses) or that have permanently darkened lenses. This is not intended to prohibit the use of eyeglasses with lenses treated to absorb ultraviolet light.

6.5.2 *Dark Adaptation*—Personnel must wait at least one minute after entering a darkened area for their eyes to adjust to the low-level lighting before performing fluorescent magnetic particle testing.

6.5.3 *Acceptance Requirements*—The acceptance requirements applicable to the part or group of parts shall be incorporated as part of the written procedure either specifically or by reference to other applicable documents containing the necessary information.

6.6 *Recording of Indications*—When required by the written procedure, the location of all rejectable indications shall be marked on the part, and permanent records of the location, direction, and frequency of indications may be made by one or more of the following methods:

6.6.1 *Written Description*—By recording the location, length, direction, and number of indications in sketch or tabular form;

6.6.2 *Transparent Tape*—For dry particle indications, by applying transparent adhesive-backed tape to which the indications will adhere and placing it on an approved form along with information giving its location on the part;

6.6.3 *Strippable Film*—By covering the indication with a spray-on strippable film that fixes the indications in place and placing the resultant reproduction on an approved form along with information giving its location on the part; and

6.6.4 *Photography*—By photographing or video recording the indications themselves, the tape, or the strippable film reproduction and placing the photograph in a tabular form along with information giving its location on the part.

6.7 *Post-Examination Demagnetization and Cleaning*—All parts shall be demagnetized and cleaned after final examination. Apply corrosion protection as required.

6.7.1 *Demagnetization*:

6.7.1.1 When using AC demagnetization, the part shall be subjected to a field with a peak value greater than, and in nearly the same direction as, the field used during examination. This AC field is then decreased gradually to zero. When using an AC demagnetizing coil, the part is passed through the coil while the current is flowing. For effective demagnetization, parts having complex configurations may require rotating or tumbling while passing through the field of the coil prior to the current being shut off. Repeat this process as necessary.

6.7.1.2 When using DC demagnetization, the initial field shall be higher than, and in nearly the same direction as, the field reached during examination. The field shall then be reversed, decreased in magnitude, and the process repeated (cycled) until an acceptably low value of residual field is reached.

6.7.1.3 Whenever possible, parts that have been magnetized circularly shall be magnetized in the longitudinal direction before being demagnetized. After demagnetization, a calibrated magnetometer shall not exceed a value agreed upon or as specified on the engineering drawing or in the contract,

purchase order, or specification. If an electronic gaussmeter is used for this measurement, the equivalency shall be determined prior to use.

6.7.2 *Post-Examination Cleaning*—Cleaning shall be done with a suitable solvent, air blower, or by other means.

6.7.2.1 Parts shall be examined to ensure that the cleaning procedure has removed magnetic particle residues from all surfaces, including holes, crevices, passage ways, etc. Such residue could have an adverse effect on the intended use of the part.

6.7.2.2 Care shall be taken to remove all plugs, masking, or other processing aids that may affect the intended use of the part.

6.7.2.3 Parts shall be protected from corrosion or damage as required.

6.8 *Record of Examination*—Results of all final magnetic particle examinations shall be recorded. All recorded results shall be identified and filed. Records shall provide for traceability to the specific part or lot examined. As a minimum, the records shall include: identification of the procedure used, disposition of the examination; identification of the inspector's examination stamp, electronic ID, or signature; and the date of examination. Records shall be kept for the duration specified in the purchase order or contract.

6.9 *Marking of Accepted Parts*—Parts that have been accepted using magnetic particle testing shall be marked in accordance with the applicable drawing, purchase order, contract prior to leaving the testing facility.

7. Quality Control

7.1 *System Performance Verification*—The overall performance of the magnetic particle testing system, including the equipment, materials, and the lighting environment being used, shall be verified initially and at regular intervals thereafter. The required verification intervals are stated in **Table 1**. Records of the verification results shall be maintained and retained for the time period specified in the contract. Establish a system in accordance with ANSI Z540.1, ANSI Z540.3, or ISO 10012 for calibration and certification of all current and voltage measuring devices, ammeter shunts, timers, visible light photometers, UV-A radiometers, gaussmeters, and magnetometers (field indicators) used in verification.

7.1.1 *Use of Test Parts with Discontinuities*—A reliable method for system performance verification is the use of representative reference parts containing discontinuities of the type, location, and size specified in the acceptance requirements and examined in accordance with a written procedure. If correct magnetic particle indications can be produced and identified in these representative parts, the overall system performance is verified. Parts used for verification will be demagnetized, cleaned thoroughly following the examination, and checked under UV-A or visible light, as appropriate to the examination process, to ensure that residual indications do not remain.

7.1.2 *Fabricated Test Parts with Artificial Discontinuities*—When actual production parts with known discontinuities of the type, location, and size needed for verification are not available or are impractical, fabricated test or production parts with

artificial discontinuities or a ring specimen (see Guide E709, Appendix X7) may be used. Artificial discontinuities may be fabricated to meet a particular need or may be commercially available shims as shown in Annex A2. All applicable conditions for the use of such reference parts, as described in 7.1.1, shall apply.

7.2 Suspension Vehicle Tests (Not Required for Aerosol Can Suspensions)

7.2.1 *Concentration/Contamination Tests*—Particle concentration and contamination shall be determined upon start up, at regular intervals thereafter, and whenever the bath is changed or adjusted. The required testing intervals are stated in Table 1.

7.2.1.1 *Determination of Wet Particle Concentration*—For recirculation systems, agitate the particle suspension a minimum of 30 min to ensure uniform distribution of particles throughout the bath. For portable application devices, agitate the particle suspension for a sufficient period of time to ensure uniform distribution of particles throughout the bath. Place a 100 mL sample of the agitated suspension in a pear-shaped centrifuge tube with a graduated stem in 0.05 mL increments for fluorescent baths and 0.1 mL for non-fluorescent baths. (Centrifuge tubes shall be as specified in Guide E709.) Demagnetize the sample and allow the tube to stand undisturbed for a settling time of at least 60 min if using petroleum distillate or at least 30 min for conditioned water suspension. Read the volume of settled particles. If the concentration is out of the tolerance stated in the written procedure add particles or suspension vehicle, as required, and re-determine the particle concentration. If the settled particles appear to be loose agglomerates rather than a solid layer, repeat the process with a second sample. If the second sample also appears agglomerated, replace the entire bath suspension. Thirty minute settling times (for petroleum distillate suspensions), or other accelerated tests, may be used if they have been verified to give results equivalent to the procedure described in this clause.

7.2.1.2 *Determination of Wet Particle Contamination*—Perform the tests specified in 7.2.1.1. Independently examine the graduated portion of the tube, under both UV-A and visible light, for striations or bands which are different in color or appearance. Bands or striations may indicate contamination. If the total volume of the contaminants, including bands or striations, exceeds 30 % of the total settled volume of magnetic particles and the contaminants, the bath must be adjusted or replaced. Clouding or fluorescence of the vehicle to the extent that the markings on the centrifuge tube which are between 5 ml and 25 ml, cannot be seen when viewed through the vehicle, the bath must be replaced.

7.2.2 *Water Break Test*—In this test of water-based vehicles, a clean part with a surface finish the same as the parts to be examined or an actual production part is flooded with the conditioned water, and the appearance of the surface is noted after flooding is stopped. Sufficient wetting agent is present if a continuous even film forms over the entire part. If the film of suspension breaks, exposing bare surface, insufficient wetting agent is present or the part has not been cleaned adequately.

For adequacy, this visual observation shall be performed individually under both UV-A or visible light conditions, or both, as applicable.

7.2.3 *Determination of Particle Sensitivity*—Appendix X2 describes several devices that can demonstrate the sensitivity of either wet-method or dry-method particles. These devices contain permanent magnetization in some form and are independent of the magnetizing system. They should not be magnetized or demagnetized before or after use. Such devices can be useful whenever performance of the particles is subject to question or needs to be verified.

7.3 Lighting:

7.3.1 *Visible Light*—Conduct visible light intensity measurements upon initial light installation, or when changes occur that would cause the light intensity to change and at the intervals specified in Table 1.

7.3.1.1 Visible light shall be used when examining with nonfluorescent magnetic particles and for interpretation of indications found with fluorescent magnetic particles. A minimum light intensity of 100 fc [1076 lx] shall be available at the surface of the part undergoing examination or evaluation.

7.3.1.2 *Ambient Visible Light*—Fluorescent magnetic particle examinations shall be performed in a darkened area with a maximum ambient visible light level of 2 fc [22 lx] measured at the part surface.

7.3.2 *UV-A Lamps*—UV-A lamps used for evaluation purposes shall meet the requirements of 7.4.5. The minimum acceptable intensity is 1000 $\mu\text{W}/\text{cm}^2$ at the surface being examined. UV-A lamps shall be checked for cleanliness and integrity and shall be cleaned, repaired, or replaced as appropriate. These checks of cleanliness/integrity need not be recorded.

7.3.2.1 UV-A lamps that use an LED source shall produce a peak wavelength at 360 to 370 nanometers as measured with a spectroradiometer. When requested, the manufacturer shall provide a certification thereof.

7.3.2.2 Battery-powered UV-A lamps used to examine parts shall have their intensity measured as specified in Table 1, and as defined by the Written Procedure (see 5.3.1). The minimum UV-A irradiance shall be maintained 1000 $\mu\text{W}/\text{cm}^2$ at the surface being examined during the period of examination.

7.3.2.3 UV-A irradiation from LED sources will typically decrease as the lamp warms up. Warm-up time as listed by the manufacturer shall be considered when measuring UV intensity.

NOTE 3—More information on UV-A sources, visible lights, radiometers, and light meters can be found in Guide E2297 and Practice E3022.

7.3.3 Where lamps are physically too large to directly illuminate the examination surface, special lighting sources, such as UV-A pencil lights, or UV-A light guides, or remote visual examination equipment shall be used. As specified in Table 1 or prior to use, the light intensity of UV-A pencil lamps, UV-A light guides, borescopes, or remote UV-A examination equipment shall be measured at the expected working distance and shall provide at least 1000 $\mu\text{W}/\text{cm}^2$ (10 W/m^2) at the intended examination surface. When using a borescope, the

image or interpretation area being viewed must have sufficient resolution to effectively evaluate the indication.

7.4 Equipment Calibration—Magnetic particle testing equipment shall be checked for performance and accuracy at the time of purchase, at the intervals indicated in **Table 1**, when a malfunction is suspected, or when electrical maintenance that might affect equipment accuracy is performed.

7.4.1 Ammeter Accuracy—To check the equipment's ammeter(s), a suitable calibrated shunt test kit with a resolution equal to or greater than the meter under test shall be connected in series with the output circuit. Comparative readings shall be taken at a minimum of three output levels encompassing the usable range of the equipment. The equipment meter reading shall not deviate by more than $\pm 10\%$ or 50 amperes, whichever is greater, from the current value shown by the calibrated ammeter. (When measuring half-wave rectified current, the current values shown by the calibrated FW-Rectified ammeter readings shall be doubled.) The frequency of the ammeter check is specified in **Table 1**. Machine output repeatability shall not vary more than $\pm 10\%$ or 50 amperes, whichever is greater, at any setpoint, and the machine under test shall be marked with the value representing the lowest repeatable current level.

7.4.2 Timer Control Check—On equipment using a timer to control the current duration, the timer should be calibrated to within ± 0.1 s using a suitable electronic timer. Comparative readings shall be taken at a minimum of three output levels encompassing the usable output range of the equipment.

7.4.3 Magnetic Field Quick Break Check—On equipment that uses a quick break feature, proper functioning of this circuit shall be verified. The check may be performed using a suitable oscilloscope or other applicable method as specified by the equipment manufacturer.

7.4.4 Dead Weight Check—Yokes shall be dead weight checked at the interval specified in **Table 1**. Alternating current yokes shall be capable of lifting at least 10 lb [4.5 kg], with a 2 to 6 in. [50 to 150 mm] spacing between legs. Direct current

yokes shall be capable of lifting at least 30 lb [13.5 kg], with a 2 to 4 in. [50 to 100 mm] spacing between legs, or 50 lb [22.5 kg], with a 4 to 6 in. [100 to 150 mm] spacing. For battery powered yokes, the check shall be performed prior to and after each use.

7.4.5 UV-A Lamps—UV-A lamps, which are portable, hand-held, permanently mounted or fixed, and used to examine parts, shall be checked for output at the frequency specified in **Table 1** and after bulb replacement. A longer period may be used if a plan justifying this extension is prepared by the NDT facility or its delegate. Minimum acceptable intensity is 1000 $\mu\text{W}/\text{cm}^2$ at 15 in. [38.1 cm] from the front of the filter to the face of the sensor. Damaged or dirty filters shall be replaced or otherwise corrected as appropriate. LED UV lamps used for evaluation purposes shall comply with Practice **E3022**.

NOTE 4—Some UV-A sources other than mercury vapor, for example, micro-discharge, LED, etc., have been shown to have emission characteristics such as excessive visible light, and UV-A intensity that may result in fluorescent fade, veiling glare, etc., all of which can significantly degrade examination reliability.

7.4.6 Hall-effect Gauss/Tesla Meters and Magnetometers (Field Indicators) shall be calibrated and a reading taken at a minimum of three points in each dynamic range and each polarity, in addition to zero.

7.4.7 UV-A Radiometers and Visible Light Photometers—These meters shall be calibrated at the interval specified in **Table 1** in accordance with manufacturers' recommended procedures and shall be traceable to the National Institute of Standards and Technology (NIST) or other recognized national standards, where applicable.

NOTE 5—More information on UV-A Radiometers and visible light Photometers can be found in Guide **E2297**.

8. Keywords

8.1 dye; fluorescent; FP; FPI; magnetic particle; MPI; MT; NDT; nondestructive evaluation; nondestructive examination; nondestructive testing

ANNEXES

(Mandatory Information)

A1. INSTRUCTIONS FOR THE USE OF AS 5371 STANDARD NOTCHED SHIMS

A1.1 Application of Shims—The Reference Standard Notched Shims of AS 5371, as shown in **Annex A2**, require specific handling, attachment, and care for accurate indication of magnetic field strength and direction. To select amperage settings for multi-directional magnetization, the use of AS 5371 shims or parts described in **6.3.1.1** is mandatory.

A1.2 Shims 0.002 in. [0.05 mm] thick shall be used on curved or complex surfaces.

A1.3 Shims are manufactured of low carbon steel and must be protected from corrosion when not in use. They may be

submerged in a solvent such as MEK or naphtha for storage. Before attaching the shim to the part, both the shim and part shall be clean and dry. Prior to use, the protective coating shall be removed from both faces of the QQI. Care shall be utilized when removing the protective coating. Excessive pressure to remove the coating may imprint the face of the QQI and cause nonrelevant indications during technique development.

NOTE A1.1—Polar solvents, such as water, will not break down the cyanoacrylate-based adhesives (super glue) commonly used to apply these shims.

A1.4 The shim shall be placed in intimate contact with the part with the flaw side next to the material to be examined.

A1.5 The shim shall be securely fastened to the part by using an adhesive or tape (such as Scotch Brand 191, 471, or 600 series) that prevents the magnetic particle suspension from entering between the shim and part. Whatever means is used to secure the shim to the part shall not interfere with the visibility of the indications.

A1.6 Tape may be used to secure the shim and shall have the following properties: (1) good adhesion to steel, (2) impervious to the suspension used, and (3) the tape shall be non-fluorescent under UV-A.

A1.7 If the tape becomes loose and allows the suspension to seep under the shim, the tape and shim shall be carefully removed from the test piece. The shim and the part shall be cleaned and dried, and then the shim shall be reattached to the test piece.

A1.8 Re-use of the shims is acceptable, provided they are not distorted when removed and intimate contact is achieved when replaced.

A1.9 **Determining Field Strength and Direction**—Use of the circle or cross configuration shims will indicate fields in any direction.

A1.9.1 In developing a magnetic particle procedure, first determine the locations the shims should be placed to ensure adequate coverage to monitor the field strength and direction, and then attach the shims.

A1.9.2 Using the continuous method, begin by starting with the amperage selection at a minimum level and increasing the amperage slowly until the shim indications are readily observed. When magnetized, one leg of the X will be indicated perpendicular to the field direction and the circle shim will

show quadrants that are approximately perpendicular to the direction of the applied field.

A1.9.3 In multi-directional magnetization, longitudinal and circular fields shall be determined separately as follows:

A1.9.3.1 Field strength for the first direction shall be determined by slowly increasing the amperage until a satisfactory indication is observed on each shim.

A1.9.3.2 Record the amperage setting and indication results.

A1.9.3.3 Demagnetize the part and carefully clean the shims prior to determining the amperage in the next direction.

A1.9.3.4 Field strength for the second direction shall be determined by incrementally increasing the amperage until a satisfactory indication is observed on each shim.

A1.9.3.5 Record the amperage setting and indication results.

A1.9.4 Place the selector switch in the multi-directional mode and magnetize the part at the previously recorded settings. If the entire circle on the shims is observed, the fields are in balance. If any portion of the circle has a weak indication, adjust the amperage accordingly and repeat the field verification process until the magnetic fields are balanced.

A1.9.5 Use care when applying the suspension to the shims. Proper shim indications may not form unless the suspension is applied in a gentle manner.

A1.10 The shims are made of a low retentivity and high permeability material that cannot be used for indicating residual fields when developing magnetic particle testing procedures.

A1.11 In unidirectional applications, the actual field strength measurements can be obtained by placing a Hall Effect probe adjacent to the shim or at a nearby location where probe placement can easily be replicated.

A2. REFERENCE STANDARD NOTCHED SHIMS FOR MAGNETIC PARTICLE TESTING IN ACCORDANCE WITH AS 5371

A2.1 The following standard flawed shims are typically used to establish proper field direction and ensure adequate field strength during technique development in magnetic par-

ticle testing. The shims shown in Fig. A2.1 may be used to

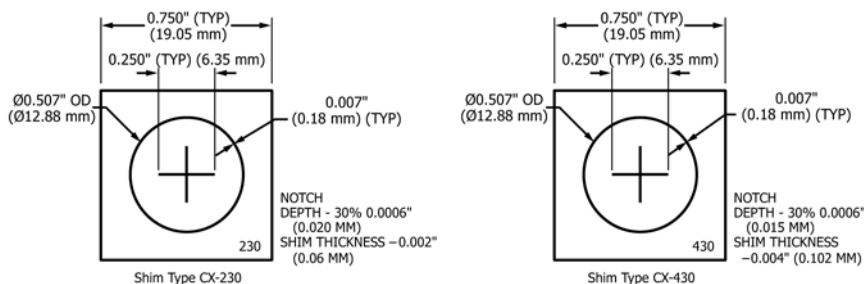

FIG. A2.1 Shims for Magnetic Particle Testing

ensure the establishment of fields in the unidirectional magnetization method and to ensure the establishment and field balance in the multidirectional magnetization method.

A2.1.1 Except for shims illustrated in Fig. A2.3, the shims are available in two thicknesses, 0.002 in. [0.05 mm] and 0.004 in. [0.10 mm]. Thinner shims are used when the thicker shims cannot conform to the part surface in the area of interest.

A2.1.2 The shims are available in two sizes, 0.75 in. [19 mm] square for Figs. Fig. A2.1 and Fig. A2.2 and 0.79 in. [20 mm] square of Fig. A2.3. The shims of Fig. A2.3 are cut, by the user, into four 0.395 in. [10 mm] square shims for use in restricted areas.

A2.1.3 Shims shall be low carbon steel, AMS 5062 or equivalent.

A2.1.4 Shims shall be used as specified in AS 5371. Shims are placed in the area(s) of interest with the notches toward the surface of the part being examined. Use enough shims by

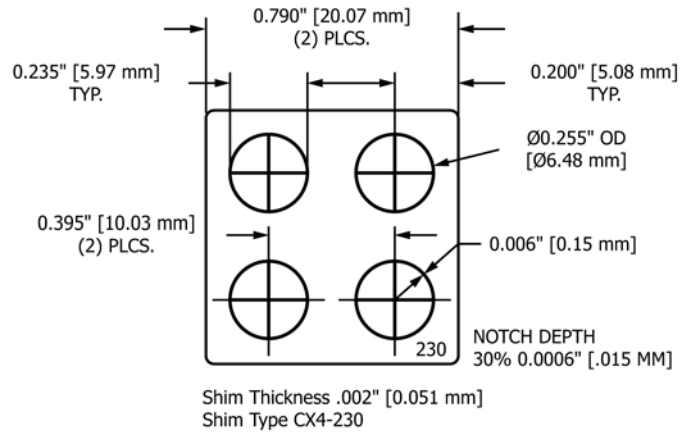

FIG. A2.3 Shims for Magnetic Particle Testing

placing the shims in multiple areas to ensure proper field directions and strengths are obtained.

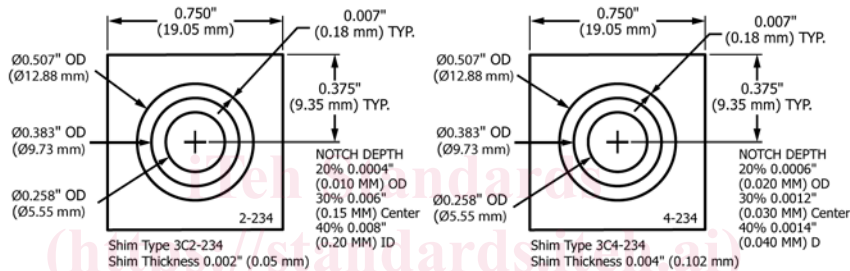

FIG. A2.2 Shims for Magnetic Particle Testing

A3. FLEXIBLE LAMINATED STRIPS FOR MAGNETIC PARTICLE TESTING

A3.1 Flexible laminated strips are typically used to ensure proper field direction during magnetic particle testing. The longitudinal axis of the strip should be placed perpendicular to the direction of the magnetic field of interest in order to generate the strongest particle indications on the strip.

A3.1.1 The strips are available in two types, General Use and Aerospace Use. Both types of strip contain a steel layer sandwiched between two brass plates that are 0.0020 in. [0.0508 mm] thick. The bottom brass layer acts as a lift-off of 0.0020 in. [0.0508 mm] from the examination surface. The brass is non-magnetic and functions only to provide lift-off and to protect the steel layer. The entire strip may have a polymeric coating for further protection.

A3.1.2 The longitudinal dimension of the strips is 1.95 in. [50 mm], and the width of the strip is 0.47 in. [12 mm].

A3.1.3 Both types of strips contain three longitudinal slots in the center steel layer.

A3.1.3.1 The widths of the slots in the General strip are 0.0075 in. [0.1905 mm], 0.009 in. [0.2286 mm], and 0.010 in. [0.254 mm].

A3.1.3.2 The widths of the slots in the Aerospace strip are 0.003 in. [0.0762 mm], 0.004 in. [0.1016 mm] and 0.005 in. [0.127 mm].

A3.1.4 The center steel layer of the strips is made of a high “μ” magnetic material.

A3.1.5 Strips shall be placed in the area(s) of interest part or surface being examined. Use enough strips, or place the strips in multiple areas to ensure that proper field directions are obtained.

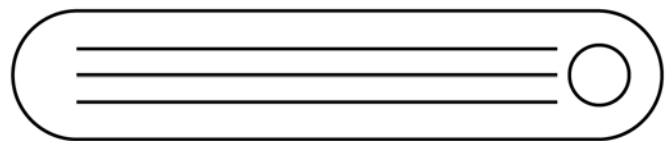

FIG. A3.1 The Longitudinal Lines Represent the Location of the Slots Cut into the Center Steel Layer of Either the General or Aerospace Flexible Laminated Strips