



Designation: ~~C78/C78M—21~~ C78/C78M – 22

Standard Test Method for Flexural Strength of Concrete (Using Simple Beam with Third-Point Loading)¹

This standard is issued under the fixed designation C78/C78M; the number immediately following the designation indicates the year of original adoption or, in the case of revision, the year of last revision. A number in parentheses indicates the year of last reappraisal. A superscript epsilon (ϵ) indicates an editorial change since the last revision or reappraisal.

This standard has been approved for use by agencies of the U.S. Department of Defense.

1. Scope*

1.1 This test method covers the determination of the flexural strength of concrete by the use of a simple beam with third-point loading.

1.2 The values stated in either SI units or inch-pound units are to be regarded separately as standard. The values stated in each system may not be exact equivalents; therefore, each system shall be used independently of the other. Combining values from the two systems may result in non-conformance with the standard.

1.3 *This standard does not purport to address all of the safety concerns, if any, associated with its use. It is the responsibility of the user of this standard to establish appropriate safety, health, and environmental practices and determine the applicability of regulatory limitations prior to use.*

1.4 *This international standard was developed in accordance with internationally recognized principles on standardization established in the Decision on Principles for the Development of International Standards, Guides and Recommendations issued by the World Trade Organization Technical Barriers to Trade (TBT) Committee.*

2. Referenced Documents

2.1 ASTM Standards:²

- [C31/C31M Practice for Making and Curing Concrete Test Specimens in the Field](#)
- [C39/C39M Test Method for Compressive Strength of Cylindrical Concrete Specimens](#)
- [C42/C42M Test Method for Obtaining and Testing Drilled Cores and Sawed Beams of Concrete](#)
- [C125 Terminology Relating to Concrete and Concrete Aggregates](#)
- [C192/C192M Practice for Making and Curing Concrete Test Specimens in the Laboratory](#)
- [C293/C293M Test Method for Flexural Strength of Concrete \(Using Simple Beam With Center-Point Loading\)](#)
- [C617/C617M Practice for Capping Cylindrical Concrete Specimens](#)
- [C670 Practice for Preparing Precision and Bias Statements for Test Methods for Construction Materials](#)
- [E1077 Practice for Agencies Testing Concrete and Concrete Aggregates for Use in Construction and Criteria for Testing Agency Evaluation](#)
- [E4 Practices for Force Calibration and Verification of Testing Machines](#)
- [E6 Terminology Relating to Methods of Mechanical Testing](#)

¹ This test method is under the jurisdiction of ASTM Committee C09 on Concrete and Concrete Aggregates and is the direct responsibility of Subcommittee C09.61 on Testing for Strength.

Current edition approved March 1, 2021/March 1, 2022. Published March 2021/March 2022. Originally approved in 1930. Last previous edition approved in 2018/2021 as C78/C78M – 18-21. DOI: 10.1520/C0078_C0078M-21.10.1520/C0078_C0078M-22.

² For referenced ASTM standards, visit the ASTM website, www.astm.org, or contact ASTM Customer Service at service@astm.org. For *Annual Book of ASTM Standards* volume information, refer to the standard's Document Summary page on the ASTM website.

*A Summary of Changes section appears at the end of this standard

3. Terminology

3.1 Definitions:

3.1.1 For definitions of terms used in this test method, refer to Terminology **C125** and Terminology **E6**.

3.2 Definitions of Terms Specific to This Standard:

3.2.1 *flexural strength*—maximum resistance of a specimen subjected to bending.

3.2.1.1 Discussion—

In this test method, *flexural strength* is reported as the *modulus of rupture*.

3.2.2 *flexural testing apparatus*—fixture used to apply force to the beam specimen and consists of loading and support blocks.

3.2.3 *loading block*—component of the testing apparatus in the shape of a portion of a cylinder that is used to apply a force to the beam specimen.

3.2.4 *modulus of rupture*—calculated stress, assuming linear-elastic behavior, in the tensile face of a beam specimen at the maximum bending moment during a standard test method.

3.2.5 *span length*—distance between lines of support, or reaction, for the beam specimen, and it is equal to three times the nominal depth of the beam.

3.2.5.1 Discussion—

For example, for a 100 mm [4 in.] nominal depth beam, the span length is 300 mm [12 in.] and for a 150 mm [6 in.] nominal depth beam, the span length is 450 mm [18 in.]. See 3.2.6.1, for discussion of *reaction block*.

3.2.6 *support block*—component of the testing apparatus in the shape of a portion of a cylinder that is used to provide a reaction to the force applied to the beam specimen.

3.2.6.1 Discussion—

If the testing apparatus applies force to the top of the beam, this block supports the beam. If the testing apparatus applies force to the bottom of the beam, the support block may be considered a reaction block because it provides a line of reaction at the top of the beam and does not support the beam.

3.2.7 *testing machine*—mechanical device for applying force to a specimen.

4. Significance and Use

4.1 This test method is used to determine the flexural strength of specimens prepared and cured in accordance with Test Methods **C42/C42M** or Practices **C31/C31M** or **C192/C192M**. Results are calculated and reported as the modulus of rupture. For the same specimen size, the strength determined will vary if there are differences in specimen preparation, curing procedure, moisture condition at time of testing, and whether the beam was molded or sawed to size.

4.2 The measured modulus of rupture generally increases as the specimen size decreases.^{3,4,5}

4.3 The results of this test method may be used to determine compliance with specifications or as a basis for mixture proportioning, evaluating uniformity of mixing, and checking placement operations by using sawed beams. It is used primarily in testing concrete for the construction of slabs and pavements.

4.4 For identical test specimens, the modulus of rupture obtained by this test method will, on average, be lower than that obtained by Test Method **C293/C293M**.

³ Tanesi, J; Ardani, A. Leavitt, J. "Reducing the Specimen Size of Concrete Flexural Strength Test (AASHTO T97) for Safety and Ease of Handling," *Transportation Research Record: Journal of the Transportation Research Board*, No. 2342, Transportation Research Board of National Academies, Washington, D.C., 2013.

⁴ Carrasquillo, P.M. and Carrasquillo, R. L "Improved Concrete Quality Control Procedures Using Third Point Loading", *Research Report 119-1F*, Project 3-9-87-1119, Center For Transportation Research, The University of Texas at Austin, November 1987.

⁵ Bazant, Z. and Novak, D. "Proposal for Standard Test of Modulus of Rupture of Concrete with its Size Dependence," *ACI Materials Journal*, January-February 2001.

5. Apparatus

5.1 *Testing Machine*—Hand operated testing machines having pumps that do not provide a continuous loading in one stroke are not permitted. Motorized pumps or hand operated positive displacement pumps having sufficient volume in one continuous stroke to complete a test without requiring replenishment are permitted and shall be capable of applying loads at a uniform rate without shock or interruption. The testing machine shall be equipped with a means of recording or holding the peak value that will indicate the maximum load, to within 1 % accuracy, applied to the specimen during a test.

5.1.1 *Verification:*

5.1.1.1 The testing machine shall conform to the requirements of the sections on Basis of Verification, Corrections, and Time Interval Between Verifications of Practice E4.

5.1.1.2 Verify the accuracy of the testing machine in accordance with Practice E4, except that the verified loading range shall be as required for flexural testing. Verification is required:

- (1) Within 13 months of the last verification,
- (2) On original installation,
- (3) After relocation,
- (4) After making repairs or adjustments that affect the operation of the force applying system or the values displayed on the load indicator, except for zero adjustments that compensate for the weight of loading or support blocks or specimen, or both, or
- (5) Whenever there is reason to suspect the accuracy of the indicated forces.

5.2 *Flexural Testing Apparatus*—The third point loading method shall be used to determine the flexural strength of concrete. The loading blocks and support blocks shall be designed so that forces applied to the beam will be along lines perpendicular to the side faces of the beam and applied without eccentricity. A diagram of the flexural testing apparatus is shown in Fig. 1.

NOTE 1—The flexural testing apparatus shown in Fig. 1 may be used inverted. In this case, the loading blocks will be at the bottom of the beam, while the reaction blocks will be at the top of the beam.

5.2.1 The flexural testing apparatus shall be capable of maintaining the span length and distance between the lines of loading within ± 1.0 mm [± 0.05 in.] of the specified values.

5.2.2 The ratio of the horizontal distance between the line of application of the force and the line of the nearest reaction to the depth of the beam shall be 1.0 ± 0.03 .

5.2.3 The loading blocks and support blocks shall not be more than 65 mm [2.50 in.] high, measured from the center or the axis of the ball or the axis of the rod and shall extend entirely across or beyond the full width of the specimen. Each case, the block

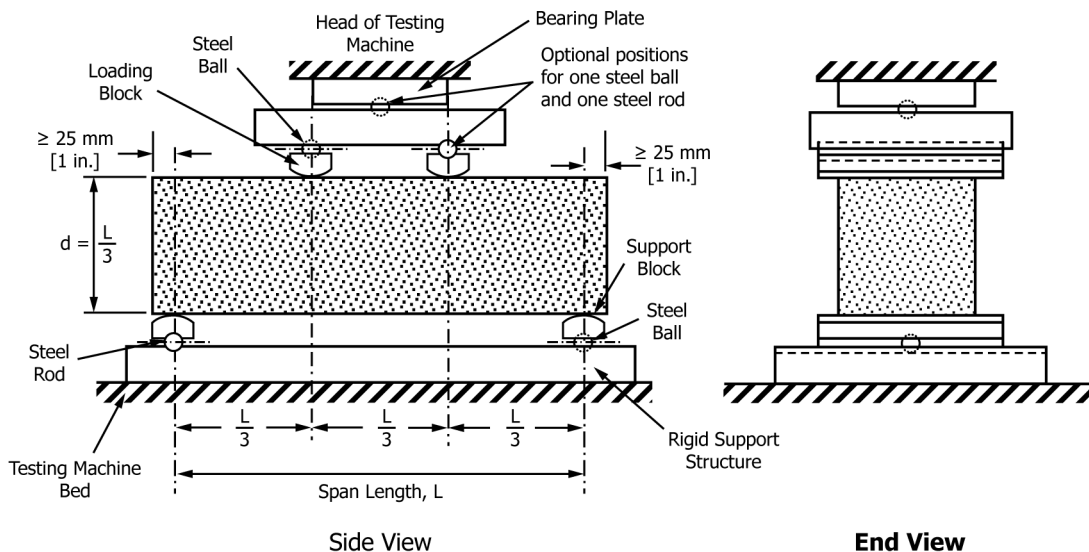

FIG. 1 Schematic of Flexural Testing Apparatus for Third-Point Loading Method

surface in contact with the specimen shall not depart from a plane by more than 0.05 mm [0.002 in.] and shall be a portion of a cylinder, the axis of which is coincidental with either the axis of the rod or center of the ball, whichever the block is pivoted upon. The angle subtended by the curved surface of each block shall be at least 0.80 rad [45°].

5.2.4 At least every six months or as specified by the manufacturer of the flexural testing apparatus, clean and lubricate metal-to-metal contact surfaces, such as internal concave surfaces and steel balls and rods of the loading blocks and support blocks (Fig. 1). The lubricant shall be a petroleum-type oil, such as conventional motor oil, or as specified by the manufacturer of the apparatus.

5.2.5 The support blocks shall be free to rotate.

5.2.6 The loading blocks and support blocks shall be maintained in a vertical position and in contact with the rod or ball by means of spring-loaded screws that hold them in contact with the rod or ball. The uppermost bearing plate and center point ball in Fig. 1 may be omitted if the testing machine has a spherically seated bearing block that meets the requirements of Test Method C39/C39M, provided one rod and one ball are used as pivots for the upper loading blocks.

6. Test Specimens

6.1 The test specimen shall conform to all requirements of Test Method C42/C42M or Practices C31/C31M or C192/C192M applicable to beam specimens and shall have a test span within 2 % of being three times its depth as tested. The sides of the specimen shall be at right angles with the top and bottom. All surfaces shall be smooth and free of scars, indentations, holes, or inscribed identification marks.

6.2 Provided the smaller cross-sectional dimension of the beam is at least three times the nominal maximum size of the coarse aggregate, the modulus of rupture can be determined using different specimen sizes. However, measured modulus of rupture generally increases as specimen size decreases.^{3,4} (Note 2).

NOTE 2—The strength ratio for beams of different sizes depends primarily on the maximum size of aggregate.⁵ Experimental data obtained in two different studies have shown that for maximum aggregate size between 19.0 mm and 25.0 mm [$\frac{3}{4}$ in. and 1 in.], the ratio between the modulus of rupture determined with a 150 mm by 150 mm [6 in. by 6 in.] and a 100 mm by 100 mm [4 in. by 4 in.] may vary from 0.90 to 1.07³ and for maximum aggregate size between 9.5 mm and 37.5 mm [$\frac{3}{8}$ in. and 1½ in.], the ratio between the modulus of rupture determined with a 150 mm by 150 mm [6 in. by 6 in.] and a 115 mm by 115 mm [4.5 in. by 4.5 in.] may vary from 0.86 to 1.00.⁴

6.3 The specifier of tests shall specify the specimen size and number of specimens to be tested to obtain an average test result. The same specimen size shall be used for qualification and acceptance testing.

7. Procedure

7.1 Moist-cured specimens shall be kept moist during the period between removal from moist storage and testing.

NOTE 3—Surface drying of the specimen results in a reduction in the measured flexural strength.

NOTE 4—Methods for keeping the specimen moist include wrapping in moist fabric or matting and keeping specimens under lime water in containers near the flexural testing machine until time of testing.

7.2 Tolerances for specimen ages are as follows:

Test Age ^A	Permissible Tolerance
24 h	± 0.5 h
3 days	±2 h
7 days	±6 h
28 days	±20 h
90 days	±2 days

^A For test ages not listed, the test age tolerance is ±2.0 % of the specified age.

7.3 For molded specimens, turn the test specimen on its side with respect to its position as molded and center it on the support blocks. When using sawed specimens, position the specimen so that the tension face corresponds to the top or bottom of the specimen as cut from the parent material. Center the loading blocks in relation to the applied force. Bring the loading blocks in

contact with the surface of the specimen at the third points and apply a force of between 3 and 6 % of the estimated ultimate force. Using 0.10 mm [0.004 in.] and 0.40 mm [0.015 in.] 0.10 mm [0.004 in.] and 0.40 mm [0.015 in.] leaf-type feeler gages, determine whether any gap between the specimen and the loading or support blocks is greater or less than each of the gages over a length of 25 mm [1 in.] 25 mm [1 in.] or more. Grind, cap, or use leather shims on the specimen contact surface to eliminate any gap in excess of 0.10 mm [0.004 in.] 0.10 mm [0.004 in.] in width. Leather shims shall be of uniform 6 mm [0.25 in.] thickness, 25 mm to 50 mm [1.0 in. to 2.0 in.] 6 mm [0.25 in.] thickness, 25 mm to 50 mm [1.0 in. to 2.0 in.] width, and shall extend across the full width of the specimen. Gaps in excess of 0.40 mm [0.015 in.] 0.40 mm [0.015 in.] shall be eliminated only by capping or grinding. Grinding of lateral surfaces shall be minimized because grinding may change the physical characteristics of the specimens. Capping shall be in accordance with the applicable sections of Practice C617/C617M.

7.4 Load the specimen continuously and without shock. The load shall be applied at a constant rate to the breaking point. Apply the load at a rate that constantly increases the maximum stress on the tension face between 0.9 MPa/min [125 psi/min] and 1.2 MPa/min [175 psi/min] until rupture occurs. The loading rate is calculated using the following equation:

$$r = \frac{Sbd^2}{L} \quad (1)$$

where:

- r = loading rate, N/min [lb/min];
- S = rate of increase in maximum stress on the tension face, MPa/min [psi/min];
- b = average width of the specimen as oriented for testing, mm [in.];
- d = average depth of the specimen as oriented for testing, mm [in.], and
- L = span length, mm [in.].

7.4.1 The limits of the loading rate are calculated by inserting the specified stress rate limits, the nominal beam dimensions (see Note 5), and the nominal span length into Eq 1 (see Note 6).

$$r = \frac{Sb_n d_n^2}{L_n} \quad (1)$$

where:

- r = upper or lower limit of loading rate, N/min [lb/min];
- S = upper or lower limit of stress rate, MPa/min [psi/min];
- b_n = nominal width of the specimen as oriented for testing, mm [in.];
- d_n = nominal depth of the specimen as oriented for testing, mm [in.], and
- L_n = nominal span length, mm [in.].

NOTE 5—The calculation of the loading rate does not require the measured dimensions of the beam specimen. However, in calculating the modulus of rupture using Eq 2, the measured dimensions are required.

NOTE 6—For example, inserting the specified stress rate limits of 0.9 MPa/min and 1.2 MPa/min [125 psi/min and 175 psi/min] into Eq 1 results in loading rate limits of 6.8 kN/min to 9.0 kN/min [1500 lb/min to 2100 lb/min] for a nominal 150 mm [6 in.] square beam with a nominal span length of 450 mm [18 in.]; and loading rate limits of 3.0 kN/min to 4.0 kN/min [670 lb/min to 930 lb/min] for a nominal 100 mm [4 in.] square beam with a nominal span length of 300 mm [12 in.].

8. Measurement of Specimens After Test

8.1 To determine the dimensions of the specimen cross section for use in calculating modulus of rupture, take measurements across one of the fractured faces after testing. The width and depth are measured with the specimen as oriented for testing. For each dimension, take one measurement at each edge and one at the center of the cross section. Use the three measurements for each direction to determine the average width and the average depth. Take all measurements to the nearest 1 mm [0.05 in.]. If the fracture occurs at a capped section, include the cap thickness in the measurement.

9. Calculation

9.1 If the fracture initiates in the tension surface within the middle third of the span length, calculate the modulus of rupture as follows: