



Designation: C1199 – 22

# Standard Test Method for Measuring the Steady-State Thermal Transmittance of Fenestration Systems Using Hot Box Methods<sup>1</sup>

This standard is issued under the fixed designation C1199; the number immediately following the designation indicates the year of original adoption or, in the case of revision, the year of last revision. A number in parentheses indicates the year of last reapproval. A superscript epsilon ( $\epsilon$ ) indicates an editorial change since the last revision or reapproval.

## 1. Scope

1.1 This test method covers requirements and guidelines and specifies calibration procedures required for the measurement of the steady-state thermal transmittance of fenestration systems installed vertically in the test chamber. This test method specifies the necessary measurements to be made using measurement systems conforming to Test Method C1363 for determination of fenestration system thermal transmittance.

NOTE 1—This test method allows the testing of projecting fenestration products (that is, garden windows, skylights, and roof windows) installed vertically in a surround panel. Current research on skylights, roof windows, and projecting products hopefully will provide additional information that can be added to the next version of this test method so that skylight and roof windows can be tested horizontally or at some angle typical of a sloping roof.

1.2 This test method refers to the thermal transmittance,  $U$  of a fenestration system installed vertically in the absence of solar radiation and air leakage effects.

NOTE 2—The methods described in this document may also be adapted for use in determining the thermal transmittance of sections of building wall, and roof and floor assemblies containing thermal anomalies, which are smaller than the hot box metering area.

1.3 This test method describes how to determine the thermal transmittance,  $U_s$  of a fenestration product (also called test specimen) at well-defined environmental conditions. The thermal transmittance is also a reported test result from Test Method C1363. If only the thermal transmittance is reported using this test method, the test report must also include a detailed description of the environmental conditions in the thermal chamber during the test as outlined in 10.1.14.

1.4 For rating purposes, this test method also describes how to calculate a standardized thermal transmittance,  $U_{ST}$ , which can be used to compare test results from laboratories with vastly different thermal chamber configurations, and facilitates

the comparison to results from computer programs that use standard heat transfer coefficients to determine the thermal transmittance of fenestration products. Although this test method specifies two methods of calculating the standardized thermal transmittance, only the standardized thermal transmittance result from one method is reported for each test. One standardized thermal transmittance calculation procedure is the Calibration Transfer Standard (CTS) Method and another is the Area Weighting (AW) Method (see Section 9 for further descriptions of these two methods). The Area Weighting method requires that the surface temperatures on both sides of the test specimen be directly measured as specified in Practice E1423 in order to determine the surface heat transfer coefficients on the fenestration product during the test. The CTS Method does not use the measured surface temperatures on the test specimen and instead utilizes the calculation of equivalent surface temperatures from calibration data to determine the test specimen surface heat transfer coefficients. The AW shall be used whenever the thermal transmittance,  $U_s$  is greater than 3.4 W/(m<sup>2</sup>·K) [0.6 Btu/(hr·ft<sup>2</sup>·°F)], or when the ratio of test specimen projected surface area to wetted (that is, total heat transfer or developed) surface area on either side of the test specimen is less than 0.80. Otherwise the CTS Method shall be used to standardize the thermal transmittance results.

1.5 A discussion of the terminology and underlying assumptions for measuring the thermal transmittance are included.

1.6 The values stated in SI units are to be regarded as the standard. The values given in parentheses are provided for information purposes only.

1.7 *This standard does not purport to address all of the safety concerns, if any, associated with its use. It is the responsibility of the user of this standard to establish appropriate safety, health, and environmental practices and determine the applicability of regulatory limitations prior to use.*

1.8 *This international standard was developed in accordance with internationally recognized principles on standardization established in the Decision on Principles for the Development of International Standards, Guides and Recommendations issued by the World Trade Organization Technical Barriers to Trade (TBT) Committee.*

<sup>1</sup> This test method is under the jurisdiction of ASTM Committee C16 on Thermal Insulation and is the direct responsibility of Subcommittee C16.30 on Thermal Measurement.

Current edition approved March 1, 2022. Published March 2022. Originally approved in 1991. Last previous edition approved in 2014 as C1199 – 14. DOI: 10.1520/C1199-22.

## 2. Referenced Documents

### 2.1 ASTM Standards:<sup>2</sup>

- C168** Terminology Relating to Thermal Insulation
- C177** Test Method for Steady-State Heat Flux Measurements and Thermal Transmission Properties by Means of the Guarded-Hot-Plate Apparatus
- C518** Test Method for Steady-State Thermal Transmission Properties by Means of the Heat Flow Meter Apparatus
- C1045** Practice for Calculating Thermal Transmission Properties Under Steady-State Conditions
- C1114** Test Method for Steady-State Thermal Transmission Properties by Means of the Thin-Heater Apparatus
- C1363** Test Method for Thermal Performance of Building Materials and Envelope Assemblies by Means of a Hot Box Apparatus
- E283** Test Method for Determining Rate of Air Leakage Through Exterior Windows, Skylights, Curtain Walls, and Doors Under Specified Pressure Differences Across the Specimen
- E631** Terminology of Building Constructions
- E783** Test Method for Field Measurement of Air Leakage Through Installed Exterior Windows and Doors
- E1423** Practice for Determining Steady State Thermal Transmittance of Fenestration Systems

### 2.2 ISO Standards:

- ISO 8990** Thermal Insulation—Determination of Steady-State Thermal Transmission Properties—Calibrated and Guarded Hot Box<sup>3</sup>
- ISO12567-1** Thermal Insulation—Thermal Performance of Windows and Doors—Determination of Thermal Transmittance by Hot Box Method—Part 1 Complete Windows and Doors<sup>3</sup>
- ISO12567-2** Thermal Insulation—Determination of Thermal Transmittance by Hot Box Method—Part 2: Roof Windows and Other Projecting Windows<sup>3</sup>

### 2.3 Other Standards:

- NFRC 100-2004** Procedure for Determining Fenestration Product Thermal U-factors<sup>4</sup>
- NFRC 102-2004** Procedure for Measuring the Steady-State Thermal Transmittance of Fenestration Systems<sup>4</sup>
- NFRC 200-2004** Procedure for Determining Fenestration Product Solar Heat Gain Coefficient and Visible Transmittance at Normal Incidence<sup>4</sup>
- BS874 Part 3, Section 3.1, 1987**, British Standard Methods for Determining Thermal Insulation Properties, (Part 3, Tests for Thermal Transmittance and Conductance, Section 3.1) Guarded Hot Box Method<sup>5</sup>
- BS874 Part 3, Section 3.2, 1990**, British Standard Methods for Determining Thermal Insulation Properties, Part 3,

Tests for Thermal Transmittance and Conductance, Section 3.2 Calibrated Hot Box Method<sup>5</sup>  
**ASHRAE Handbook-Fundamentals 2009**<sup>6</sup>

## 3. Terminology

3.1 *Definitions*—Definitions and terms are in accordance with definitions in Terminologies **E631** and **C168**, from which the following have been selected and modified to apply to fenestration systems. See **Fig. 1** for temperature locations.

### 3.2 Definitions of Terms Specific to This Standard:

3.2.1 *apparent thermal conductance*—A thermal conductance assigned to a material that exhibits thermal transmission by several modes of heat transfer resulting in property variation with specimen thickness, or surface emittance.

3.2.2 *calibration transfer standard, n*—an insulation board with a known measured thermal conductance that is faced with glazing, and instrumented with temperature sensors either between the glazing and the insulation board core or on the exterior surface of the glazing, which is used to calibrate the surface resistances and the surround panel (see **Annex A1** for design guidelines for Calibration Transfer Standards).

3.2.3 *projecting products, n*—a non-planar product where the glazing projects outward past the cold side surround panel surface plane (that is, skylights, garden windows).

3.2.4 *standardized thermal transmittance, n*— $U_{ST}$ , the heat transmission in unit time through unit area of a test specimen and standardized boundary air films, induced by unit temperature difference between the environments on each side.

3.2.5 *surface heat transfer coefficient, n*— $h$ , (sometimes called *surface conductance* or *film coefficient*.) the time rate of heat flow from a unit area of a surface to its surroundings, induced by a unit temperature difference between the surface and the environment.

3.2.6 *surround panel* (sometimes called the *mask*, *mask wall*, or *homogeneous wall*), *n*—a homogeneous panel with an opening where the Calibration Transfer Standard or the test specimen is installed. When there is no test specimen aperture, or the opening is filled with the same thickness of surround panel assembly, it is called a characterization panel. (see **5.1.1.1**, and Annex A11 of Test Method **C1363** for a description of surround panels and characterization panels.)

3.2.7 *test specimen, n*—the fenestration system or product being tested.

3.2.8 *thermal transmittance, n*— $U_S$  (sometimes called the overall coefficient of heat transfer) the heat transfer in unit time through unit area of a test specimen and its boundary air films, induced by unit temperature difference between the environments on each side.

3.3 *Symbols*—The symbols, terms, and units used in this test method are as follows:

<sup>2</sup> For referenced ASTM standards, visit the ASTM website, [www.astm.org](http://www.astm.org), or contact ASTM Customer Service at [service@astm.org](mailto:service@astm.org). For *Annual Book of ASTM Standards* volume information, refer to the standard's Document Summary page on the ASTM website.

<sup>3</sup> Available from American National Standards Institute (ANSI), 25 W. 43rd St., 4th Floor, New York, NY 10036, <http://www.ansi.org>.

<sup>4</sup> Available from National Fenestration Rating Council, 6305 Ivy Lane, Suite 140, Greenbelt, MD 20770.

<sup>5</sup> Available from British Standards Institute (BSI), 389 Chiswick High Rd., London W4 4AL, U.K., <http://www.bsi-global.com>.

<sup>6</sup> Available from American Society of Heating, Refrigerating, and Air-Conditioning Engineers, Inc. (ASHRAE), 1791 Tullie Circle, NE, Atlanta, GA 30329, <http://www.ashrae.org>.

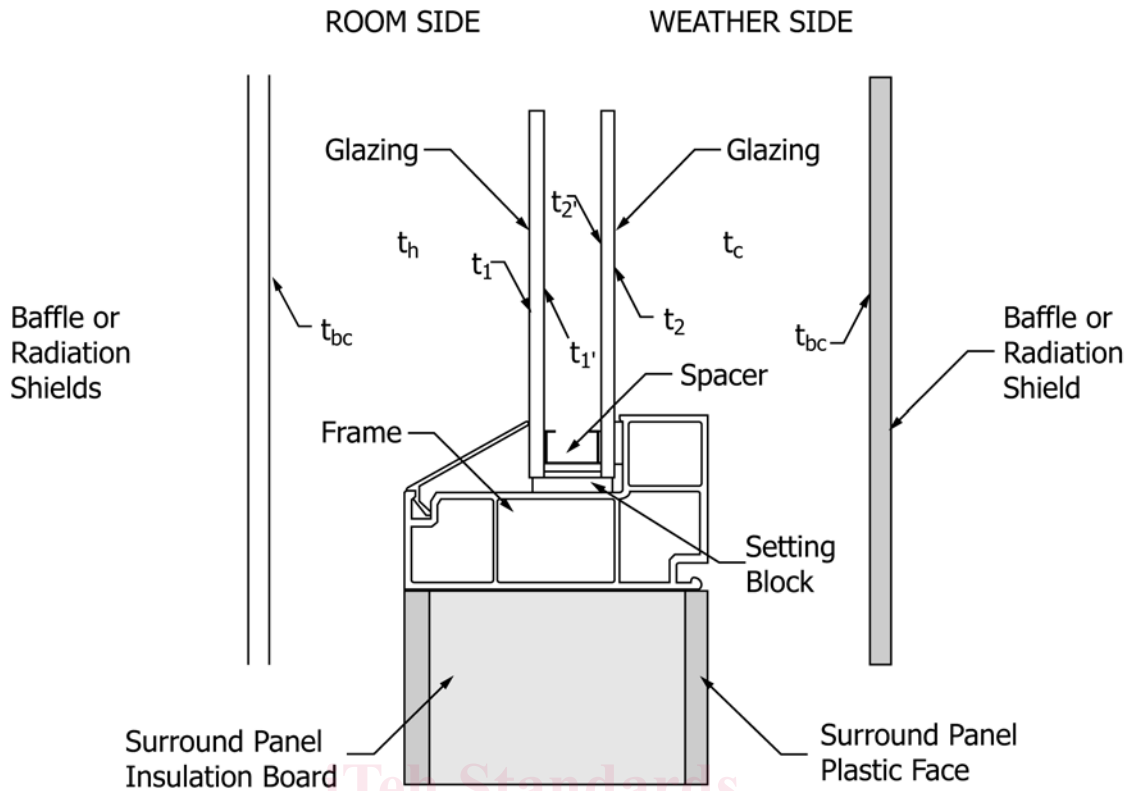

FIG. 1 Schematic Representation of Various Temperatures for Fenestration Systems

$A_h$	= total heat transfer (or developed) surface area of test specimen on room side, $m^2$ ,	$C_{ts[assembly]}$	= apparent thermal conductance of calibration transfer standard assembly, $W/(m^2 \cdot K)$ , determined by means of Practice C1045 used with either Test Method C177 and Test Method C518 or Test Method C1114.
$A_c$	= total heat transfer (or developed) surface area of test specimen on weather side, $m^2$ ,	$\epsilon$	= total hemispherical emittance of surface,
$A_{b1}$	= area of room side baffle and all other surfaces in view of the test specimen, $m^2$ ,	$h_{STh}$	= standardized surface heat transfer coefficient, room side, $(W/m^2 \cdot K)$ ,
$A_{b2}$	= area of weather side baffle and all other surfaces in view of the test specimen, $m^2$ ,	$h_{STc}$	= standardized surface heat transfer coefficient, weather side, $(W/m^2 \cdot K)$ ,
$A_S$	= projected area of test specimen (same as test specimen aperture in surround panel), $m^2$ ,	$h_h$	= surface heat transfer coefficient, room side, $W/(m^2 \cdot K)$ ,
$A_{sp}$	= projected area of surround panel (does not include test specimen aperture in surround panel), $m^2$ ,	$h_c$	= surface heat transfer coefficient, weather side, $W/(m^2 \cdot K)$ ,
$\alpha$	= absorptance of surface,	$K_c$	= convection coefficient, $W/(m^2 \cdot K^{1.25})$ ,
$C_g$	= apparent thermal conductance of glass or acceptable transparent plastic facing on calibration transfer standard, $W/(m^2 \cdot K)$ ,	$L$	= length of heat flow path, m,
$C_{sp}$	= apparent thermal conductance of surround panel (surface to surface), $W/(m^2 \cdot K)$ , determined by means of Practice C1045 used with either Test Method C177, Test Method C518 or Test Method C1114,	$Q$	= time rate of heat flow through the total surround panel/test specimen system, W,
$C_{ts[core]}$	= apparent thermal conductance of calibration transfer standard core, $W/(m^2 \cdot K)$ , determined by means of and Practice C1045 used with either Test Method C177, Test Method C518 or Test Method C1114	$Q_c$	= time rate of convective heat flow from test specimen surface, W,
		$Q_{fl}$	= time rate of flanking loss heat flow around surround panel, W,
		$Q_r$	= time rate of net radiative heat flow from test specimen surface to the surroundings, W,
		$Q_S$	= time rate of heat flow through the test specimen, W,

$Q_{sp}$	= rime rate of heat flow through the surround panel as determined from measured conductance $C_{ts}$ and area weighted surround panel surface temperatures, W,
$q$	= heat flux (time rate of heat flow through unit area), $W/m^2$ ,
$q_S$	= heat flux through the test specimen, $W/m^2$ ,
$q_{r1}$	= net radiative heat flux to the room side of the test specimen, $W/m^2$ ,
$q_{r2}$	= net radiative heat flux from the weather side of the test specimen, $W/m^2$ ,
$q_{c1}$	= convective heat flux to the room side of the test specimen, $W/m^2$ ,
$q_{c2}$	= convective heat flux from the weather side of the test specimen, $W/m^2$ ,
$\rho$	= reflectance of surface,
$r_h$	= surface resistance, room side, $m^2 \cdot K/W$ ,
$r_c$	= surface resistance, weather side, $m^2 \cdot K/W$ ,
$R_S$	= overall thermal resistance of test specimen (air to air under test conditions), $m^2 \cdot K/W$ ,
$t_{b1}$	= equivalent radiative baffle surface temperature, room side, K or $^{\circ}C$ ,
$t_{b2}$	= equivalent radiative baffle surface temperature, weather side, K or $^{\circ}C$ ,
$t_h$	= average temperature of room side air, $^{\circ}C$ ,
$t_c$	= average temperature of weather side air, $^{\circ}C$ ,
$t_1$	= average area weighted temperature of test specimen room side surface, K or $^{\circ}C$ ,
$t_2$	= average area weighted temperature of test specimen weather side surface, K or $^{\circ}C$ ,
$t_{sp1}$	= area-weighted room side surround panel surface temperature, K or $^{\circ}C$ ,
$t_{sp2}$	= area-weighted weather side surround panel surface temperature, K or $^{\circ}C$ ,
$t_1'$	= average area weighted temperature of room side glass/core interface of calibration transfer standard, K or $^{\circ}C$ ,
$t_2'$	= average area weighted temperature of weather side glass/core interface of calibration transfer standard, K or $^{\circ}C$ ,
$U_S$	= thermal transmittance of test specimen (air to air under test conditions), $W/(m^2 \cdot K)$ ,
$U_{ST}$	= standardized thermal transmittance of test specimen, $W/(m^2 \cdot K)$ ,
$U_{ST[AW]}$	= standardized thermal transmittance of test specimen determined using measured Area Weighted [AW] surface temperatures (air to air), $W/(m^2 \cdot K)$ , and
$U_{ST[CTS]}$	= standardized thermal transmittance of test specimen determined using Calibration Transfer Standard [CTS] surface heat transfer coefficients (air-to-air), $W/(m^2 \cdot K)$ .

#### 4. Significance and Use

4.1 This test method details the calibration and testing procedures and necessary additional temperature instrumentation required in applying Test Method **C1363** to measure the thermal transmittance of fenestration systems mounted vertically in the thermal chamber.

4.2 The thermal transmittance of a test specimen is affected by its size and three-dimensional geometry. Care must be exercised when extrapolating to product sizes smaller or larger than the test specimen. Therefore, it is recommended that fenestration systems be tested at the recommended sizes specified in Practice **E1423** or NFRC 100.

4.3 Since both temperature and surface heat transfer coefficient conditions affect results, use of recommended conditions will assist in reducing confusion caused by comparing results of tests performed under dissimilar conditions. Standardized test conditions for determining the thermal transmittance of fenestration systems are specified in Practice **E1423** and Section **6.2**. The performance of a test specimen measured at standardized test conditions is potentially different than the performance of the same fenestration product when installed in the wall of a building located outdoors. Standardized test conditions often represent extreme summer or winter design conditions, which are potentially different than the average conditions typically experienced by a fenestration product installed in an exterior wall. For the purpose of comparison, it is essential to calibrate with surface heat transfer coefficients on the Calibration Transfer Standard (CTS) which are as close as possible to the conventionally accepted values for building design; however, this procedure can be used at other conditions for research purposes or product development.

4.4 Similarly, it would be desirable to have a surround panel that closely duplicates the actual wall where the fenestration system would be installed. Since there are such a wide variety of fenestration system openings in North American residential, commercial and industrial buildings, it is not feasible to select a typical surround panel construction for installing the fenestration system test specimen. Furthermore, for high resistance fenestration systems installed in fenestration opening designs and constructions that have thermal bridges, the large relative amount of heat transfer through the thermal bridge will cause the relatively small amount of heat transfer through the fenestration system to have a larger than desirable error. For this reason, the Calibration Transfer Standard and test specimen are installed in a homogeneous surround panel constructed from materials having a relatively high thermal resistance. Installing the test specimen in a relatively high thermal resistance surround panel places the focus of the test on the fenestration system thermal performance alone. Therefore, it is important to recognize that the thermal transmittance results obtained from this test method are for ideal laboratory conditions, and should only be used for fenestration product comparisons unless the thermal bridge effects that have the potential to occur due to the specific design and construction of the fenestration system opening are included in the analysis.

4.5 This test method does not include procedures to determine the heat flow due to either air movement through the specimen or solar radiation effects. As a consequence, the thermal transmittance results obtained do not reflect performances that are expected from field installations. It is possible to use the results from this test method as input to annual energy performance analyses which include solar, and air leakage effects to get a better estimate of how the test specimen

would perform when installed in an actual building. To determine the Solar Heat Gain Coefficient of fenestration products, refer to NFRC 200. To determine air leakage for windows and doors, refer to Test Methods E283 and E783.

4.6 It is important to recognize that the thermal transmittance,  $U_S$ , value determined in Section 8 is the only true experimental measurement result of this test method. The “standardized” thermal transmittance value,  $U_{ST}$ , obtained by either the Calibration Transfer Standard (CTS) or Area Weighting (AW) methods described in Section 8 include adjustments to the thermal transmittance value based on results from calibration runs described in Section 6. The standardized thermal transmittance is useful for two reasons; it facilitates comparison of test results between different laboratories with different thermal chamber geometries and configurations, and it improves the comparison between test results and computer simulation results. Due to the differences in size, geometry, and climate chamber air flow permitted by this test method, Test Method C1363, and Practice E1423, there can be significant variations in the local surface heat transfer coefficients on the same test specimen installed in different laboratories even though these laboratories measured identical surface heat transfer coefficients on their Calibration Transfer Standards. Inter-Laboratory Comparisons conducted by the NFRC have shown that the effect of this variation is reduced if the standardized thermal transmittance is used for comparison instead of the thermal transmittance. The standardized thermal transmittance is also a useful tool for the evaluation and comparison of experimental results of fenestration systems with computer calculations of the thermal transmittance. That are made because the current Historically, computer calculation methods (NFRC 100) for determining the thermal transmittance were not capable of applying the actual surface heat transfer coefficients that exist on the test specimen while testing at standardized conditions. These current computer calculation methods assumed that uniform standardized surface heat transfer coefficients exist on the indoor and outdoor fenestration product surfaces. Although the next generation of computer simulation programs includes improved radiation heat transfer algorithms, which generate non-uniform surface heat transfer coefficients, the standardized thermal transmittance remains to be a useful tool when comparing test results to computer modeling results.

4.6.1 It is important to recognize that due to radiation effects, the room side or weather side temperature ( $t_h$  and  $t_c$ , respectively), has the potential to differ from the respective room side or weather side baffle temperatures ( $t_{b1}$  and  $t_{b2}$ , respectively). If there is a difference of more than  $\pm 1$  °C ( $\pm 2$  °F), either on the room side or weather side, the radiation effects shall be accounted for as described in Sections 6 and 9 to maintain accuracy in the calculated surface heat transfer coefficients. Calculating the radiation exchange for highly conductive test specimens or projecting fenestration products as described in Annex A2 is not a trivial task.

4.6.2 The calculation of the standardized thermal transmittance assumes that only the surface heat transfer coefficients change from the calibrated standardized values for the conditions of the test. This assumption is possibly not valid if the

surface temperature differentials for the standardized calibration conditions are different from the surface temperature differential that exists on the test specimen during the test. Currently, specifications for the Calibration Transfer Standard give it a thermal transmittance of  $1.7 \text{ W}/(\text{m}^2 \cdot \text{K})$  [ $0.3 \text{ Btu}/(\text{hr} \cdot \text{ft}^2 \cdot ^\circ\text{F})$ ]. Accordingly, the calculation of the standardized thermal transmittance produces the least error when performed on test specimens with a similar thermal transmittance.

4.6.3 It is important to note that the standardized surface heat transfer coefficients,  $h_h$  and  $h_c$ , as calibrated prior to testing a fenestration product using an appropriately sized Calibration Transfer Standard (CTS) have the potential to differ from the surface heat transfer coefficients that exist during a hot box test on a specific test specimen. Fenestration systems usually have frame and sash surfaces that introduce two- and three-dimensional convective heat transfer effects which result in variable surface heat transfer coefficients, which differ from the uniform standardized values. As a result of this, the test specimen surface heat transfer coefficients will differ from those obtained with the non-framed, essentially flat Calibration Transfer Standard tested under the same conditions. In this standardizing procedure, it is assumed that the differences are small enough so that the calibration surface heat transfer coefficients can be used to calculate equivalent test specimen average surface temperatures,  $t_1$  and  $t_2$ , in order to estimate the actual test specimen surface heat transfer coefficients. It is important to recognize that this assumption will not be accurate for all fenestration products, especially for high thermal transmittance products where the surface heat transfer coefficients are a major portion of the overall thermal resistance and also for fenestration products with significant surface projections (for example, skylights, roof windows, garden windows) where the surface heat transfer coefficients are quite different from the standardized values.

4.6.4 In these situations, it is important to attempt to measure the test specimen surface temperature distributions and then calculate directly the test specimen average area weighted surface temperatures,  $t_1$  and  $t_2$ . This area weighting (AW) method also has problems in that the placement of temperature sensors to get an accurate area weighting is not known, especially on high conductivity horizontal surfaces that act as heat transfer extended surfaces (that is, fins). In addition, the placement of many temperature sensors on the test specimen surfaces will affect the velocity fields in the vicinity of these surfaces which will affect the surface temperatures and surface heat transfer coefficients.

## 5. Apparatus

5.1 *General Thermal Chamber*—This section specifies the additional equipment and instrumentation necessary to calibrate, and measure the thermal transmittance of fenestration systems using a thermal chamber as described in Test Method C1363. Keep in mind that Test Method C1363 describes the overall construction, calibration and operation of the thermal chamber and surround panel as well as additional air flow measurements and power measurements that are not described in detail in this test method.

### 5.1.1 *Equipment:*

5.1.1.1 *Surround Panel*—As explained in 4.4 there is the potential for a strong interaction between the heat flow in an actual surrounding wall and the frame of the fenestration system. If the surrounding wall construction contains highly conductive materials, the heat flow through the fenestration system frame could be significantly changed. Since it is not feasible to select a typical wall to use as a surround panel, it is desirable to have a relatively high-resistance surround panel to minimize this “shorting” interaction so that the heat flow through the fenestration system itself can be measured as accurately as possible. This is especially true for the highly resistive “superwindows” currently being developed.

(1) A surround panel, consisting of a stable homogeneous thermal insulation material with an apparent thermal conductance at 24 °C not in excess of 0.03 W/(m · K) [0.21 (Btu · in)/(hr · ft<sup>2</sup> · °F)] and having a very low gas permeance (an air permeance less than 1.0E-10 m<sup>2</sup> has been found to be satisfactory), shall be provided for mounting the test specimen (see Fig. 2). Surround panels shall be constructed, characterized, and instrumented using the procedures described in Annex A11 of Test Method C1363.

5.1.1.2 *Calibration Transfer Standard*—The test facility surface heat transfer coefficients shall be calibrated using a heat flux transducer Calibration Transfer Standard constructed as described in Annex A1 and illustrated in Fig. 2(a) and Fig. 2(b). The Calibration Transfer Standard has a core material of known characteristics traceable to primary standards such as the guarded hot plate of a national standard laboratory. The projected dimensions and areas of the Calibration Transfer Standards need to cover the same range as the test specimen model sizes and tolerances as specified in Practice E1423 or NFRC 100. A minimum of two Calibration Transfer Standards shall be used; one approximately the largest specimen size to be tested and one approximately the smallest specimen size to be tested. The Calibration Transfer Standard calibration coefficients (that is,  $h_h$ ,  $h_c$ , and  $K$ ) used to standardize the thermal transmittance shall be those from the Calibration Transfer Standard closest to the size of the test specimen. See 6.2 for the values of the standardized surface heat transfer coefficients required for using this test method for rating purposes.

NOTE 3—It is recommended that a minimum of three Calibration Transfer Standards be used that cover the range of test specimen model sizes that a laboratory plans to test. One approximately the smallest model size to be tested, one approximately the average model size to be tested, and one approximately the largest model size to be tested.

5.1.2 *Instrumentation:*

5.1.2.1 *Power measurements*—The total power to heaters, fans or blowers, and any significant power to instrument transducers within the metering box shall be measured or determined over the duration of the test. See 6.12 of Test Method C1363 for a full description of power measurement requirements.

5.1.2.2 *Temperature measurements*—In addition to the air and surface area weighted temperature measurements specified in Test Method C1363, the following temperature measurements are required:

(1) *Radiating surface temperatures*—The temperature of all surfaces (baffles, surround panel opening, box surfaces,

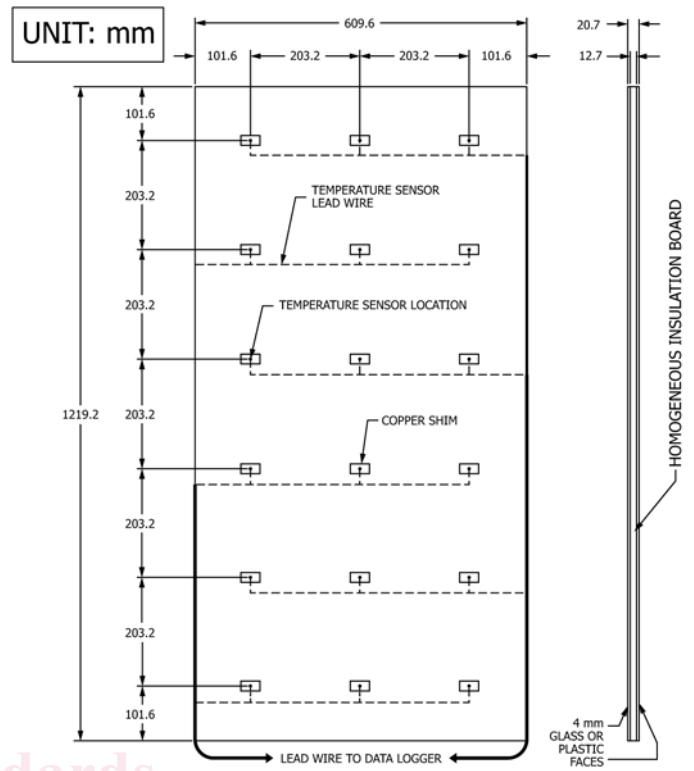

FIG. 2 (a) Example Calibration Transfer Standard Design Information

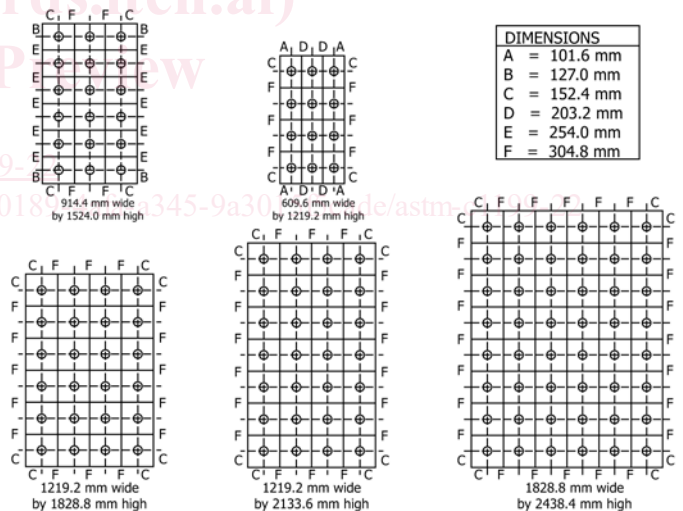

FIG. 2 (b) Minimum Temperature Sensors Array for Typical CTS

shields, etc) exchanging radiation heat transfer with the test specimen using the same area weighing criteria as specified in Test Method C1363.

(2) *Air temperatures*—The room side and weather side air stream temperatures in a plane parallel to the surround panel surfaces shall be measured as specified in 6.10.3.1 of Test Method C1363. The air temperature sensors shall be located 75 mm (3 in.) from the surface of the surround panel. The rows and columns closest to the metering box walls shall be located at a minimum distance of 150 mm (6 in.) from each meter box

wall. It is desirable to measure each of the air temperature thermocouples individually, but if the thermocouples are to be electrically averaged, ensure that the thermocouple leads within an averaged group are the same length and that each averaged group is confined to individual horizontal rows.

**NOTE 4**—The temperature sensor requirements given in 5.1.2.2, 5.1.2.2(1), and 5.1.2.2(2) are minimum requirements. Section 7.5.2 on temperature measurements requires additional temperature sensors which are dependent on the test specimen type. It is acceptable to use more temperature sensors if they provide more accurate average temperature (air and surface) values.

**5.1.2.3 Air Leakage**—Practice E1423 describes the equipment, instrumentation and methodology used to verify that all the Calibration Transfer Standards and test specimens are sealed in the surround panel before testing.

**5.1.2.4 Wind Velocity Measurements**—As stipulated in 7.5.4, both the weather and meter side wind velocity shall be measured and recorded at locations that represents free stream conditions for the duration of the test. A sensor with an accuracy of  $\pm 5\%$  of the reading is required.

**5.1.2.5 Relative Humidity Measurements**—Instrumentation shall be used to measure and record the Relative Humidity within the metering box for the duration of the test. It is also recommended that the Relative Humidity within the guard and climate chambers as well as the ambient laboratory environment be monitored.

**5.1.2.6 Glazing Deflection**—Equipment or instrumentation, or both, used to measure the glazing deflection of multiple-pane glazing systems is required. Measurements shall be reported for each test specimen as specified in Section 8 of Practice E1423.

## 6. Calibration

**6.1 Calibration requirements**—A minimum of two calibration test procedures shall be performed to determine the metering box wall transducer and surround panel flanking loss coefficients,  $[E_o + Q_{fl}]$ , and to characterize the surface heat transfer coefficients on a Calibration Transfer Standard before testing actual fenestration products. The first calibration test requires that a continuous surround panel (with the test specimen aperture filled with the same material as the rest of the surround panel) be tested at standard test conditions in order to determine the metering box wall and surround panel heat transfer characteristics. In the second set of calibration tests, a Calibration Transfer Standard with its weather side face located 25 mm in from the weather side edge of the surround panel opening shall be mounted in the surround panel and tested at standardized conditions. Adjust the fans in the thermal chamber so that the surface heat transfer coefficients measured on both sides of the Calibration Transfer Standard are within a set tolerance of the standardized surface heat transfer coefficients (see 6.2). The design, construction and instrumentation of Calibration Transfer Standards are presented in Annex A1.

**6.1.1 Metering Box Wall Transducer and Flanking Loss Test Procedure**—Install a continuous surround panel or *characterization panel* (one without a test specimen aperture, or with the aperture filled with surround panel material of equal thickness) in the thermal chamber and attach temperature sensors to both sides at the density described in Test Method C1363, Annex 11.

Seal the characterization panel as per 7.5 and Annex 11 of Test Method C1363. The heat flow through the characterization panel as determined by its area, the surface temperature difference on both sides of the characterization panel, and the apparent thermal conductance of the characterization panel's materials (as determined by Test Methods C177, C518, or C1114) is compared to the metered heat flow that is input into the metering chamber (after it is corrected for the heat flow through the metering chamber walls determined as per Annex A1 and Annex A6 of Test Method C1363) Typically this test is performed at least three times for each characterization panel; one test with the guard chamber air temperature above the metering chamber air temperature, one with the guard and metering air temperature almost equal, and one test with the guard air temperature below the metering box air temperature. The results from these three tests are used to determine the metering box wall transducer and surround panel flanking loss coefficients,  $[E_o + Q_{fl}]$ , for each characterization panel. The thinnest and thickest surround panels shall be tested first, and if the differences between the metering box wall transducer and flanking loss coefficients are negligible, intermediate thicknesses of surround panel are not required to be tested. If the differences between the thickest and thinnest surround panels is significant then separate metering box wall transducer and surround panel flanking loss coefficients shall be determined for each combination of materials and thicknesses of surround panels and environmental conditions used for testing; as per Annex A6 of Test Method C1363.

**NOTE 5**—It is convenient to measure the time constant of the thermal chamber and the surround panel at this time. The time constant is used to determine when a particular test has achieved steady-state conditions, and is determined using the process described in Section A10 of Test Method C1363. A continuous surround panel (that is, with the test specimen aperture filled with surround panel material) can be used as a conservative estimate of the time constant of most window test specimens, which have a thermal capacity and diffusivity less than an equivalent sized surround panel material. Therefore it is useful to determine the time constant of a thermal chamber and surround panel at the same time that the flanking loss is determined.

### 6.1.2 Calibration Transfer Standard Test Procedure:

**6.1.2.1** Install the Calibration Transfer Standard with the weather side surface 25 mm (1 in.) in from the surround panel weather side surface (see Fig. 3). Seal the cracks around the perimeter of the Calibration Transfer Standard with nonmetallic tape or caulking, or both, to prevent air leakage. It is desirable to measure each of the surface temperature thermocouples in the Calibration Transfer Standard individually, but if the thermocouples are to be electrically averaged, ensure the thermocouple leads within an averaged group are the same length and that each averaged group is confined to individual horizontal rows. The design construction and instrumentation of Calibration Transfer Standards are presented in Annex A1.

**6.1.2.2** Establish, as per Test Method C1363 steady-state thermal conditions for which the surround panel and Calibration Transfer Standard is to be calibrated and record the metering box and climate chamber fan speeds, measurements of power, temperature, and velocity. The methodology and criteria used to determine steady state for fenestration testing described in Note 23 in Section 10.11.3 of Test Method C1363 is considered to be the minimum mandatory requirements.

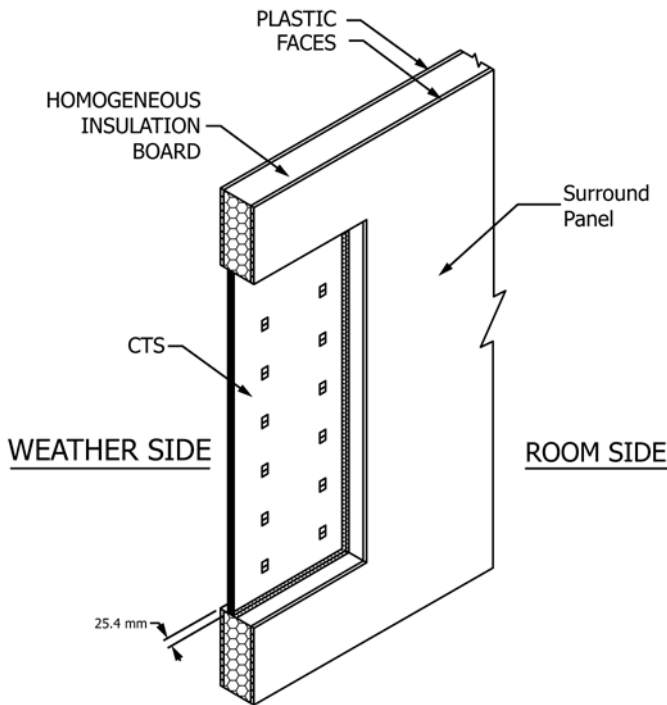

FIG. 3 Surround Panel With CTS

6.1.3 Calibration Transfer Standard Data Analysis:

6.1.3.1 Total Heat Flow—The time rate of heat flow through the test assembly (surround panel and Calibration Transfer Standard),  $Q$ , is determined by the procedures specified in Test Method C1363.

6.1.3.2 Calibration Transfer Standard Heat Flow— $Q_s$ , is calculated differently depending if the temperature sensors are located on the inside or the outside of the facing material:

(1) CTS with interior thermocouples—If the temperature sensors are located between the glazing and the core, the Calibration Transfer Standard Heat Flow,  $Q_s$ , is calculated as follows:

$$Q_s = C_{ts[core]} \cdot A_s \cdot (t_1 - t_2) \quad (1)$$

where:

$C_{ts[core]}$  = conductance of Calibration Transfer Standard core,  $W/(m^2 \cdot K)$ , as determined by either Test Methods C177, C518, or C1114 and Practice C1045,

$A_s$  = area of Calibration Transfer Standard,  $m^2$ ,

$t_1$  = average equal area weighted temperature of room side glass/core interface of calibration standard,  $^{\circ}C$  (see Fig. 1), and

$t_2$  = average equal area weighted temperature of weather side glass/core interface of calibration standard,  $^{\circ}C$  (see Fig. 1).

(2) CTS with exterior thermocouples—If the temperature sensors are located on the exterior surface of the glazing, the Calibration Transfer Standard Heat Flow,  $Q_s$ , is calculated as follows:

$$Q_s = C_{ts[assembly]} \cdot A_s \cdot (t_1 - t_2) \quad (2)$$

$C_{ts[assembly]}$  = conductance of Calibration Transfer Standard core assembly, including the core and facing materials,  $W/(m^2 \cdot K)$ , as determined by either Test Methods C177, C518, or C1114 and Practice C1045,

$A_s$  = area of Calibration Transfer Standard,  $m^2$ ,

$t_1$  = equal area weighted average room side Calibration Transfer Standard surface temperature,  $^{\circ}C$ ,

$t_2$  = equal area weighted average weather side calibration transfer standard surface temperature,  $^{\circ}C$ ,

6.1.3.3 Surround panel heat flow,  $Q_{sp}$ , is then:

$$Q_{sp} = C_{sp} \cdot A_{sp} \cdot (t_{sp1} - t_{sp2}) \quad (3)$$

where:

$A_{sp}$  = surround panel area,  $m^2$ ,

$t_{sp1}$  = area weighted room side surround panel surface temperature,  $^{\circ}C$ , and

$t_{sp2}$  = area weighted weather side surround panel surface temperature,  $^{\circ}C$ .

NOTE 6—The apparent thermal conductance of all of the rigid insulation foams used as the core of Calibration Transfer Standards and surround panels are a function of the mean temperature of that material. The mean temperature corrections for the Calibration Transfer Standard and the surround panel are previously established by measuring the apparent thermal conductance at three different mean temperature conditions as required in Annex A1, and Annex A11 of Test Method C1363.

6.1.3.4 If  $t_{b1} = t_h \pm 1^{\circ}C$  ( $\pm 2^{\circ}F$ ) and  $t_{b2} = t_c \pm 1^{\circ}C$  ( $\pm 2^{\circ}F$ ) see 6.1.3.6 to determine the surface heat transfer coefficients. If calculated values of the surface temperatures are to be used in the calculation procedure specified in Section 9, Calculation of Standardized Thermal Transmittance, then also carry out the calculation procedures specified in 6.1.3.7 to determine the convection coefficient,  $K_c$ .

6.1.3.5 If  $t_{b1} > t_h + 1^{\circ}C$  ( $2^{\circ}F$ ) or  $t_{b1} < t_h - 1^{\circ}C$  ( $2^{\circ}F$ ) and  $t_{b2} > t_c + 1^{\circ}C$  ( $2^{\circ}F$ ) or  $t_{b2} < t_c - 1^{\circ}C$  ( $2^{\circ}F$ ), see 6.1.3.7 to determine the surface heat transfer coefficients.

6.1.3.6 Surface heat transfer coefficients,  $h_h$  and  $h_c$ , when  $t_{b1} = t_h \pm 1^{\circ}C$  ( $\pm 2^{\circ}F$ ) and  $t_{b2} = t_c \pm 1^{\circ}C$  ( $\pm 2^{\circ}F$ ), are calculated as follows:

$$h_h = Q_s / (A_s \cdot (t_h - t_1)) \quad (4)$$

where:

$t_h$  = average room side air temperature,  $^{\circ}C$ , and

$t_1$  = equal area weighted average room side Calibration Transfer Standard surface temperature,  $^{\circ}C$ . If the temperature sensors are located between the glazing and the core, the room side surface temperature is calculated as follows:

$$t_1 = t_{1'} + C_{ts} \cdot (t_{1'} - t_2) / C_g \quad (5)$$

where:

$C_g$  = conductance of facing on calibration transfer standard,  $W/(m^2 \cdot K)$ .

NOTE 7—The apparent thermal conductance of the glazing layer is the thermal conductivity of the glazing material divided by the glazing layer thickness. A value of  $1 W/(m \cdot K)$  for the thermal conductivity of float glass is recommended if the actual value is not provided by the manufacturer. In other cases, such as laminated or plastic glazing, the glazing manufacturer



should provide the measured thermal conductivity of the glazing material.

$$h_c = Q_s / (A_s \cdot (t_2 - t_c)) \quad (6)$$

where:

$t_c$  = average weather side air temperature, °C, and  
 $t_2$  = equal area weighted average weather side calibration transfer standard surface temperature, °C, If the temperature sensors are located between the glazing and the core, the weather side surface temperature is calculated as follows:

$$t_2 = t_2' - C_{ts} \cdot (t_1' - t_2') / C_g \quad (7)$$

6.1.3.7 Surface heat transfer coefficients,  $h_h$  and  $h_c$  when  $t_{b1} > t_h + 1^\circ\text{C}$  (2°F) or  $t_{b1} < t_h - 1^\circ\text{C}$  (2°F) and  $t_{b2} > t_c + 1^\circ\text{C}$  (2°F) or  $t_{b2} < t_c - 1^\circ\text{C}$  (2°F), are calculated as follows:

(1) Room Side Radiative Heat Transfer,  $Q_{r1}$ —When the room side baffle or box wall is close to the test specimen, parallel plate radiative heat transfer can be assumed. Then:

$$q_{r1} = Q_{r1} / A_s = 1 / (1/\epsilon_1 + 1/\epsilon_{b1} - 1) \cdot \sigma \cdot [(t_{b1} + 273.15)^4 - (t_1 + 273.15)^4] \quad (8)$$

where:

$\epsilon_1$  = emittance of room-side facing surface (glass or plastic),  
 $\epsilon_{b1}$  = radiant average emittance of the baffle/shield/surround panel opening/box wall and all other surfaces in view of the test specimen,  
 $t_{b1}$  = area weighted radiant average baffle/shield/box wall/surround panel opening surface temperature in view of the test specimen, °C, and  
 $\sigma$  = Stefan-Boltzmann constant =  $5.67 \times 10^{-8}$ , W/(m<sup>2</sup> · K<sup>4</sup>).

NOTE 8—If the test specimen surface views anything other than the baffle/shield/box wall/surround panel opening surfaces, or if the baffle/shield/box wall/surround panel opening is not isothermal to within  $\pm 1^\circ\text{C}$  ( $\pm 2^\circ\text{F}$ ) then the radiative heat transfer calculation procedure in Annex A2 is required. Isothermal to within  $\pm 1^\circ\text{C}$  ( $\pm 2^\circ\text{F}$ ) is determined by comparing each of the individual baffle/shield/box wall/surround panel temperature measurements to the mean of all the baffle/shield/box wall/surround panel opening temperature measurements. If any of the individual baffle/shield/box wall/surround panel opening temperature measurements differ from the mean by more than  $\pm 1^\circ\text{C}$  ( $\pm 2^\circ\text{F}$ ), then the radiative heat transfer calculation procedure in Annex A2 is required. Hot box operators should recognize that the radiative calculation procedure in Annex A2 adds to the complexity of the tests being conducted. For many hot boxes, additional baffle/shield/box wall/surround panel opening and other surrounding surfaces have to have their temperatures accurately measured and recorded, and the more complex radiative heat transfer analysis specified in Annex A2 may have to be added to the data analysis. To circumvent this, hot box operators should make the necessary modifications to their facilities so that the surrounding baffle/shield/box wall/surround panel opening temperatures are isothermal to within  $\pm 1^\circ\text{C}$  ( $\pm 2^\circ\text{F}$ ) and the mean baffle/shield/box wall/surround panel opening temperature is within  $\pm 1^\circ\text{C}$  ( $\pm 2^\circ\text{F}$ ) of the respective air temperature. A simple solution for many hot box designs would be to add a large, flat baffle that is parallel to the surround panel. If a large isothermal baffle is located close enough to the surround panel so that the test specimen (or Calibration Transfer Standard) “sees” only the baffle and the surround panel opening surfaces, the experimental data analysis does not have to include the more complex radiative heat transfer calculation procedure specified in Annex A2. This greatly simplifies the test procedure and the experimental data analysis.

(2) Room Side Convective Heat Transfer,  $Q_{c1}$ :

$$Q_{c1} = Q_s - Q_{r1} \quad (9)$$

and:

$$q_{c1} = Q_{c1} / A_s \quad (10)$$

Also, using Eq 10, the convection constant  $K_c$  in Eq 11 for the convective heat transfer to the test specimen can be determined.

$$K_c = q_{c1} / (t_h - t_1)^{1.25} \quad (11)$$

NOTE 9—The convective heat transfer calculation assumes natural convection on the room side of the Calibration Transfer Standard. To ensure that a single convection coefficient,  $K_c$ , can be used for fenestration system tests, its behavior should be investigated, using the Calibration Transfer Standard, over the range of heat flows expected. The hot box operator may use a convective correlation different from Eq 11 if it is more appropriate for the convective heat transfer situation that exists for that operator’s hot box. However, the test report should include the alternative form of Eq 11 used and the alternative value of the convection constant  $K_c$  obtained.

(3) Room Side Surface Heat Transfer Coefficient,  $h_h$ —From Eq 8 and 10:

$$h_h = (q_{r1} + q_{c1}) / (t_h - t_1) \quad (12)$$

where  $t_1$  is directly measured or calculated in accordance with Eq 5.

(4) Weather Side Radiative Heat Transfer,  $Q_{r2}$ —The following procedure is used when testing under the conditions specified in 6.1.3.5. Assuming large parallel plate radiative heat exchange; then:

$$q_{r2} = Q_{r2} / A_s = 1 / (1/\epsilon_2 + 1/\epsilon_{b2} - 1) \cdot \sigma \cdot [(t_2 + 273.15)^4 - (t_{b2} + 273.15)^4] \quad (13)$$

where:

$\epsilon_2$  = emittance of weather-side facing surface (glass or plastic),  
 $\epsilon_{b2}$  = radiant average emittance of the baffle/shield/surround panel opening/box wall and all other surfaces in view of the test specimen,  
 $t_{b2}$  = area weighted radiant average baffle/shield/box wall/surround panel opening surface temperature in view of the test specimen, °C, and  
 $\sigma$  = Stefan-Boltzmann constant =  $5.67 \times 10^{-8}$ , W/(m<sup>2</sup> · K<sup>4</sup>).

NOTE 10—If the test specimen surface views anything other than the baffle/shield/surround panel opening/box wall, or if the baffle/shield/surround panel opening/box wall is not isothermal to within  $\pm 1^\circ\text{C}$  ( $\pm 2^\circ\text{F}$ ), then the radiative heat transfer calculation procedure in Annex A2 is required. Isothermal to within  $\pm 1^\circ\text{C}$  ( $\pm 2^\circ\text{F}$ ) is determined by comparing each of the individual baffle/shield/surround panel opening/box wall temperature measurements to the mean of all the baffle/shield/surround panel opening/box wall temperature measurements. If any of the individual baffle/shield/surround panel opening/box wall temperature measurements differ from the mean by more than  $\pm 1^\circ\text{C}$  ( $\pm 2^\circ\text{F}$ ), then the radiative heat transfer calculation procedure in Annex A2 is required.

(5) Weather Side Convective Heat Transfer,  $Q_{c2}$ :

$$Q_{c2} = Q_s - Q_{r2} \quad (14)$$

and

$$q_{c2} = Q_{c2} / A_s \quad (15)$$

(6) Weather Side Surface Heat Transfer Coefficient,  $h_c$ —From Eq 13 and 15:

$$h_c = (q_{r2} + q_{c2}) / (t_c - t_2) \quad (16)$$

where  $t_2$  is directly measured or calculated in accordance with Eq 7.

## 6.2 Standardized Surface Heat Transfer Coefficients:

6.2.1 Thermal Chamber Velocity Adjustments—The results from the Calibration Transfer Standard tests are used for two purposes. The primary objective is to adjust the air velocities in

the room and weather side of the thermal chamber so that they produce standardized surface heat transfer coefficients, within the tolerances specified below, on both sides of each Calibration Transfer Standard used. The second objective is to determine the convection coefficient,  $K_c$ , and the weather side surface heat transfer coefficient,  $h_c$ , for use in the CTS method of calculating the standardized thermal transmittance (see 9.2.1).

6.2.2 The impinging air flow (for perpendicular and parallel air flow directions) on the Calibration Transfer Standard needs to be as uniform as possible. After the calibration tests have been performed, the test laboratory shall compare the surface heat transfer coefficients measured on each Calibration Transfer Standard with the standardized heat transfer coefficients specified in 6.2.3 and 6.2.4. If the surface heat transfer coefficients measured on a Calibration Transfer Standard are outside of the tolerance specified in 6.2.3 and 6.2.4, then the laboratory shall adjust the fan speeds, plenums, or thermal chamber configuration to meet the specified tolerance before running tests on fenestration products. If the surface heat transfer coefficients generated on the Calibration Transfer Standard are not within the tolerances specified in 6.2.3 and 6.2.4, then the actual Calibration Transfer Standard surface heat transfer coefficients shall be clearly identified in the test report, and only the thermal transmittance,  $U_s$ , shall be reported. The standardized thermal transmittance shall not be reported unless the surface heat transfer coefficients generated on the Calibration Transfer Standard are within the tolerance specified in 6.2.3 and 6.2.4.

6.2.3 *Room Side Standardized Surface Heat Transfer Coefficient*—The standardized surface heat transfer coefficient measured on the room side of each Calibration Transfer Standard shall be:

$$h_{sth} = 7.67 \text{ W/m}^2 \cdot \text{K} \pm 5\% \quad (1.35 \text{ Btu/hr} \cdot \text{ft}^2 \cdot ^\circ\text{F} \pm 5\%) \quad (17)$$

[Allowed CTS calibration range of:

$$7.29 \text{ to } 8.05 \text{ W/m}^2 \cdot \text{K} \quad (1.28 \text{ to } 1.42 \text{ Btu/hr} \cdot \text{ft}^2 \cdot ^\circ\text{F})$$

NOTE 11—Using the 2009 ASHRAE Handbook-Fundamentals, Fenestration Chapter 15, Table 3, the indoor side of the overall combined natural convection, and radiation surface heat transfer coefficient for a 1.2 m (4 ft) high, 13 mm (0.5 in.) wide cavity, double glazed, low emittance glazing unit is 6.98 W/(m<sup>2</sup>·K). For a 1.2 m (4 ft) high, 13 mm (0.5 in.) thick high-density expanded polystyrene (EPS) foam core Calibration Transfer Standard (CTS) with two 4 mm glass faces, the indoor side calculated overall combined natural convection, radiation surface heat transfer coefficient is 7.02 W/(m<sup>2</sup>·K) using the same methods and equations that were used to obtain the ASHRAE Chapter 15, Table 3 results. Rounding off these two results gives a nominal standardized surface heat transfer coefficient of 7 W/(m<sup>2</sup>·K) (1.23 Btu/(hr·ft<sup>2</sup>·°F)), which is the natural convection lower limit for this size CTS. The room side standardized surface heat transfer coefficient has been set slightly above this level to allow a small amount of forced convection to provide a more uniform flow distribution on the indoor side of the CTS and test specimen.

6.2.4 *Weather Side Standardized Surface Heat Transfer Coefficient*—The standardized surface heat transfer coefficient measured on the weather side of each Calibration Transfer Standard shall be:

$$h_{stc} = 30.0 \text{ W/m}^2 \cdot \text{K} \pm 10\% \quad (5.28 \text{ Btu/hr} \cdot \text{ft}^2 \cdot ^\circ\text{F} \pm 10\%) \quad (18)$$

[Allowed CTS calibration range of:

$$27.0 \text{ to } 33.0 \text{ W/m}^2 \cdot \text{K} \quad (4.75 \text{ to } 5.81 \text{ Btu/hr} \cdot \text{ft}^2 \cdot ^\circ\text{F})$$

NOTE 12—Again, referring to the 2009 ASHRAE Handbook-

Fundamentals, Fenestration Chapter 15, the recommended design value for the weather side overall combined forced convection, and radiation surface heat transfer coefficient for a nominal 24 km/h (15 mile per hour) wind speed is  $h_c = 29 \text{ W/(m}^2 \cdot \text{K)}$  (5.1 Btu/(hr·ft<sup>2</sup>·°F)). The standardized coefficient has been slightly increased to be in harmonization with NFRC 100. On the other hand, the ASHRAE value of 29 W/(m<sup>2</sup>·K) comes from heat transfer experiments on a 0.3 m by 0.3 m (1 ft by 1 ft) flat plate. On a larger 1.22 m (4 ft) high Calibration Transfer Standard, the forced convection heat transfer coefficient will tend to be lower due to the continued growth of the boundary layer, thus reducing the weather side overall combined forced convection, and radiation surface heat transfer coefficient. The degree of this reduction depends on a number of factors, including the flow conditioning before it reaches the surface of the Calibration Transfer Standard, the initial flow direction (parallel or perpendicular), the flow regimen along the Calibration Transfer Standard surface (completely laminar or turbulent over a portion of the Calibration Transfer Standard) and the depth that the Calibration Transfer Standard is recessed in the surround panel opening. Therefore, to account for this and to also allow lower nominal weather side wind speeds to be used to adjust the weather side overall combined forced convection, and radiation surface heat transfer coefficient, a ±10% variation in the weather side standardized value is allowed.

## 7. Experimental Procedure

7.1 Detailed written operating procedures for each test apparatus shall be developed and shall be available to ensure that the tests are conducted in accordance with the requirements of this test method.

7.2 *Installation of Fenestration System*—The fenestration system to be tested needs to be installed in the surround panel with a configuration that simulates the actual installation as closely as possible. That is, the complete assembly including all frame elements needs to be in place during the test. The surround panel requirements specified in 5.1.1.1 and the sealing requirements specified in 5.1.2.2 (for the Calibration Transfer Standard) also apply to the test specimen. See 7.2 of Practice E1423 for further guidance on installation.

7.3 *Test Conditions*—Wherever the temperatures and standard heat transfer coefficients are not otherwise specified, 6.2 and Practice E1423 should be used as guides for selecting the appropriate test temperature conditions.

7.4 *Stabilization and Test Times*—Establish, as per 10.9 of Test Method C1363, steady-state temperature and power conditions for which the test specimen is to be tested and record measurements of power, temperatures, Relative Humidity and velocity at maximum interval of five minutes throughout the period of the test. The methodology and criteria used to determine steady state for fenestration testing described in Note 23 in 10.11.3 of Test Method C1363 are considered to be the minimum mandatory requirements.

### 7.5 Recorded Test Measurements:

7.5.1 *Power Measurements*—The total net heat transfer or average power transferred through the test specimen during a measurement interval. The energy balance to determine this should account for all metering box heating and cooling, power to fans or blowers, any significant power to instrument transducers, corrections for the surround panel heat flow, the metering box wall heat transfer and surround panel flanking heat transfer, any other extraneous heat flows, and corrections for the energy flow (enthalpy difference times air leakage mass flow rate) associated with any air leakage entering and leaving

the metering chamber. See Test Method **C1363** for a full description of power measurement requirements, and the means to determine metering box and surround panel heat transfer.

**7.5.2 Temperature Measurements**—All measurements specified in Test Method **C1363**. The temperature sensors used need to be special limit (premium) thermocouples (24 gage may be used; 30 gage or smaller are recommended for the test specimen surface temperatures), or appropriate size thermistors or RTD's (resistance temperature detectors).

**7.5.2.1** Additional temperature measurements shall be made on the surround panel surfaces as specified in Annex A11.4.1 of Test Method **C1363**.

**7.5.2.2** For determining the Area-Weighted, and the standardized thermal transmittance,  $U_{ST [AW]}$ , it will be necessary to make additional temperature measurements on the fenestration test specimen frame, glazing (center and near edges) and on any other surfaces (sills, muntins, etc.) in order to provide a representative area weighted value of the surface temperatures of the specimen. It must be recognized that there is such a wide range of fenestration system designs that it is not possible to specify the locations of the temperature sensors to provide a correct area weighted determination of the various surface temperatures for all configurations. See Practice **E1423** for additional guidance on the location of test specimen surface temperature sensors for different fenestration systems. The weighted heat transfer surface areas used with the frame/sash temperature measurements shall add up to the total surface area of the frame/sash in contact with the surrounding air. Also, any area weighted surface temperatures determined in this manner shall be compared with the calculated equivalent room side and weather side surface temperatures specified in **9.2.1** and **9.2.2**. If a discrepancy exists, it is possibly due to either the temperature calculation process or the placing of the area weighted temperature sensors. The technique of area weighted temperature measurements is potentially necessary (see discussions in **4.1** and **4.6**) when the frame and glazing conductances are dissimilar or the surface geometry is complicated or projects out into the weather side chamber, or both. If this is the case, excessive use of temperature sensors has the potential to cause the measured surface heat transfer coefficients,  $h_h$  and  $h_c$  to differ from the actual heat transfer coefficients, introducing further uncertainty in the results. The temperature sensors used shall be placed so as to minimize the disturbance of the air flows on the surfaces of the test specimen.

**7.5.2.3** It is desirable that temperature measurements be made in the room side and weather side air streams in the same quantity and spacing as the surface temperature sensors (see 6.10.3 of Test Method **C1363**). This will allow for a more accurate measurement of the room side and weather side surface heat transfer coefficients.

**7.5.3 Radiation Effects**—To minimize the effect of radiation-induced error on the temperature sensors, the temperatures of all surfaces exchanging radiation heat transfer with the fenestration system (test specimen or calibration transfer standard) shall be measured. This includes: (1) room side and weather side shields and baffles, (2) air distribution system components, and (3) hot box walls and portions of the surround

panel that are in view of the test specimen. Any heating and cooling devices must be shielded from the surround panel/fenestration system and measure the surface temperature of the shield. The temperature sensors must be applied to these surfaces with tape or adhesive that has an emissivity similar to that of the surface. Ensure that the air temperature sensors are either shielded or are as small as possible so that they are not significantly affected by surfaces with which they are exchanging radiation (see 6.10.3 of Test Method **C1363**).

**7.5.4 Wind Speed Measurements**—The weather side wind speed shall be measured at a location that represents the free stream condition. For both perpendicular and parallel flow patterns, it is required that this location be a distance out in the air stream such that the wind speed sensor is not in the test specimen surface boundary layers or wakes. A minimum distance of 75 mm (3 in.) out from the test specimen center point is recommended. The hot box operator's experience and knowledge of the air distribution system and hot box design needs to be drawn upon to determine the proper location.

**7.5.4.1** Mapping the velocity fields on both the room and weather sides by periodic traversing of the air flow field to determine the air velocity distribution is recommended at every calibration interval to verify that a uniform air flow is directed at or across the face of the test specimen. (See Test Method **C1363**, 6.8.10.1 for more detail.)

**7.5.4.2** On the room side, where natural convection conditions are desired, it is required to mount a velocity sensor at a location that represents the average velocity so that natural convection conditions can be verified and the room side average air velocity can be measured during the test.

**7.5.4.3** The types of acceptable air speed sensors are not specified within this test method. However, an accuracy of  $\pm 5\%$  of the reading is required.

**7.5.5 Relative Humidity Measurements**—The Relative Humidity within the metering box shall be monitored and recorded for the duration of the test. The metering box Relative Humidity shall be maintained at or below 15 % over the period of the test with the following exception; a metering box Relative Humidity greater than 15 % and less than 25 % is allowed if there is no indication of condensation on the specimen during the test. In those situations where the metering box Relative Humidity exceeds 15 % during the test, the laboratory shall record a minimum of three specimen surface temperatures at the expected coldest points on the warm side of the specimen to demonstrate that the surface temperatures during the test remained above the dew point. The lowest measured temperatures and the approximate location of those "coldest" surface temperatures shall be included in the test report.

**7.5.6 Glazing Deflection**—Glazing deflection measurements shall be reported for each test specimen as specified in Section 8 of Practice **E1423**.

## 8. Calculation of Thermal Transmittance

**8.1 General Calculations**—The following shall be calculated for each test:

**8.1.1 Total Heat Flow,  $Q$** —The time rate of heat input into the metering box corrected for the metering box wall heat