



Designation: ~~F1802~~—~~15~~ F1802 – 22

## Standard Test Method for Performance Testing of Excess Flow Valves<sup>1</sup>

This standard is issued under the fixed designation F1802; the number immediately following the designation indicates the year of original adoption or, in the case of revision, the year of last revision. A number in parentheses indicates the year of last reapproval. A superscript epsilon ( $\epsilon$ ) indicates an editorial change since the last revision or reapproval.

### 1. ~~Scope~~ Scope\*

1.1 This test method covers a standardized method to determine the performance of excess flow valves (EFVs) designed to limit flow or stop flow in thermoplastic natural gas service lines.<sup>2</sup>

1.2 All tests are intended to be performed using air as the test fluid. Unless otherwise stated, all flow rates are reported in standard cubic feet per hour of 0.6 relative density natural gas.

1.3 The test method recognizes two types of EFV. One type, an excess flow valve-bypass (EFVB), allows a small amount of gas to bleed through (bypass) after it has tripped, usually as a means of automatically resetting the device. The second type, an excess flow valve-non bypass (EFVNB), is intended to trip shut forming an essentially gas tight seal.

1.4 The performance characteristics covered in this test method include flow at trip point, pressure drop across the EFV, bypass flow rate of the EFVB or leak rate through the EFVNB after trip, and verification that the EFV can be reset.

1.4.1 Gas distribution systems may contain condensates and particulates such as organic matter, sand, dirt, and iron compounds. Field experience has shown that the operating characteristics of some EFVs may be affected by accumulations of these materials. The tests of Section 11 were developed to provide a simple, inexpensive, reproducible test that quantifies the effect, if any, of a uniform coating of kerosene and of kerosene contaminated with a specified amount of ferric oxide powder on an EFV's operating characteristics.

1.5 Excess flow valves covered by this test method will normally have the following characteristics: a pressure rating of up to 125 psig (0.86 MPa); a trip flow of between ~~200~~200 ft<sup>3</sup>/h and 2500 ft<sup>3</sup>/h (~~5.66~~5.66 m<sup>3</sup>/h and 70.8 m<sup>3</sup>/h) at 10 psig (0.07 MPa); a minimum temperature rating of 0°F (–18°C), and a maximum temperature rating of ~~100~~100°F (~~38~~38°C).

1.6 The EFVs covered by this test method shall be constructed to fit piping systems no smaller than ½ CTS and no larger than 1¼ IPS, including both pipe and tubing sizes.

1.7 Tests will be performed at ~~67~~67 °F ± 10°F (~~19.4~~19.4 °C ± 5.5°C). Alternative optional test temperatures are ~~100 ± 10~~100 ± 10°F (~~37.7 ± 5.5~~37.7 ± 5.5°C) and 0 ± 10°F (–18 ± 5.5°C). All flow rates must be corrected to standard conditions.

<sup>1</sup> This test method is under the jurisdiction of ASTM Committee F17 on Plastic Piping Systems and is the direct responsibility of Subcommittee F17.40 on Test Methods. Current edition approved Nov. 1, 2015; Feb. 1, 2022. Published May 2016; April 2022. Originally approved in 1995 as PS 13–95. Last previous edition approved in 2010 as F1802–04(2010); F1802–15. DOI: 10.1520/F1802-15.10.1520/F1802-22.

<sup>2</sup> This contamination test procedure may be utilized to determine the effect, if any, of contaminants from a specific gas distribution system on the operational characteristics of an EFV under consideration for use in that system. Condensates, oils and particulates removed from that distribution system could be substituted for kerosene and iron oxide. Results obtained from using reagents or contaminants other than those specified in this test method must not be used in comparison with results obtained using the reagents specified in this test method.

\*A Summary of Changes section appears at the end of this standard

1.8 This test method was written for EFVs installed in thermoplastic piping systems. However, it is expected that the test method may also be used for similar devices in other piping systems.

1.9 The values stated in inch-pound units are to be regarded as standard. The values given in parentheses are mathematical conversions to SI units that are provided for information only and are not considered standard.

*1.10 This standard does not purport to address all of the safety concerns, if any, associated with its use. It is the responsibility of the user of this standard to establish appropriate safety and health practices and determine the applicability of regulatory limitations prior to use. For specific precautions, see Section 8.*

1.10 This standard does not purport to address all of the safety concerns, if any, associated with its use. It is the responsibility of the user of this standard to establish appropriate safety, health, and environmental practices and determine the applicability of regulatory limitations prior to use. For specific precautions, see Section 8.

1.11 This international standard was developed in accordance with internationally recognized principles on standardization established in the Decision on Principles for the Development of International Standards, Guides and Recommendations issued by the World Trade Organization Technical Barriers to Trade (TBT) Committee.

## 2. Referenced Documents

### 2.1 ASTM Standards:<sup>3</sup>

D1600 Terminology for Abbreviated Terms Relating to Plastics

E177 Practice for Use of the Terms Precision and Bias in ASTM Test Methods

E691 Practice for Conducting an Interlaboratory Study to Determine the Precision of a Test Method

F412 Terminology Relating to Plastic Piping Systems

### 2.2 ANSI Standard:

B31.8 Gas Transmission and Distribution Piping Systems<sup>4</sup>

### 2.3 Federal Specification:

DOT Part 192 Title 49 Code of Federal Regulations<sup>5</sup>

## 3. Terminology

### 3.1 Definitions:

3.1.1 *General*—Definitions are in accordance with Terminology F412, unless otherwise specified. Abbreviations are in accordance with Terminology D1600.

3.1.2 The gas industry terminology used in this test method is in accordance with ANSI B31.8 or DOT Part 192 Title 49, unless otherwise indicated.

### 3.2 Definitions of Terms Specific to This Standard:

3.2.1 *bypass flow, n*—the flow through an EFVB after it has been activated or tripped.

3.2.2 *excess flow valve (EFV), n*—a device installed in a natural gas service line having the ability to automatically stop or limit the flow of gas in the event that the flow in the service line exceeds a predetermined level.

3.2.2.1 *excess flow valve-bypass (EFVB), n*—an EFV designed to limit the flow of gas upon closure to a small predetermined level. The EFVBs reset automatically, once the service line downstream is made gas tight and pressure is equalized across the valve.

3.2.2.2 *excess flow valve-non bypass (EFVNB), n*—an EFV which is designed to stop the flow of gas upon closure. The EFVNBs must be manually reset.

3.2.3 *leak rate, n*—the flow of test fluid passing through an EFVNB after it has been activated or tripped.

<sup>3</sup> For referenced ASTM standards, visit the ASTM website, [www.astm.org](http://www.astm.org), or contact ASTM Customer Service at [service@astm.org](mailto:service@astm.org). For *Annual Book of ASTM Standards* volume information, refer to the standard's Document Summary page on the ASTM website.

<sup>4</sup> Available from American National Standards Institute (ANSI), 25 W. 43rd St., 4th Floor, New York, NY 10036, <http://www.ansi.org>.

<sup>5</sup> Available from Superintendent of Documents, U.S. Government Printing Office, 732 N. Capitol Street, NW, Washington, DC 20402.

3.2.4 *Piezometer ring, n*—a device installed at a pressure measurement point in a flowing gas stream intended to eliminate the effect of the flowing gas on the measurement device. See Appendix X1.

3.2.5 *pipe, n*—refers to both pipe and tubing.

3.2.6 *standard conditions, n*—for gas flow conversion, 0.6 relative density natural gas at 14.7 psia (0.1 MPa) and 60°F (16.6 °C).

3.2.7 *trip, n*—activation of the mechanism of an EFV to stop or limit the flow of natural gas in the service line.

3.2.8 *trip flow, n*—the flow passing through an EFV required to cause its activation to stop or limit flow.

**4. Summary of Test Method**

4.1 For all tests, air is intended to be the test fluid. All flows are given in cubic feet per hour of 0.6 relative density natural gas, unless otherwise specified. All tests are to be performed at 67.67 °F ± 10°F (19.410 °F (19.4 °C ± 5.5°C); 5.5 °C), with alternative test temperatures of 0 and 100°F (-17.7100 °F (-17.7 °C and 37.7°C); 37.7 °C). All flow rates must be corrected to standard conditions using the temperature of the air flow measured just upstream of the flowmeter (T<sub>2</sub>) in Fig. 1.

4.2 The EFV is installed in the standardized test apparatus shown in Fig. 1. This apparatus provides regulated inlet pressure, pressure measurement at specified locations, temperature measurement, flow measurement, and flow control. Four discrete tests are performed on each sample, as follows:

4.2.1 *Trip Flow Rate*—The EFV is installed in the test apparatus and the flow control valve is slowly opened. At the trip point, the inlet pressure and flow rate are recorded.

4.2.2 *Bypass or Leak Rate*—After completion of trip flow rate test, the flow past the tripped device is measured on Flowmeter 2. For an EFVB, this flow is the bypass flow. For an EFVNB, this flow is the leak rate.

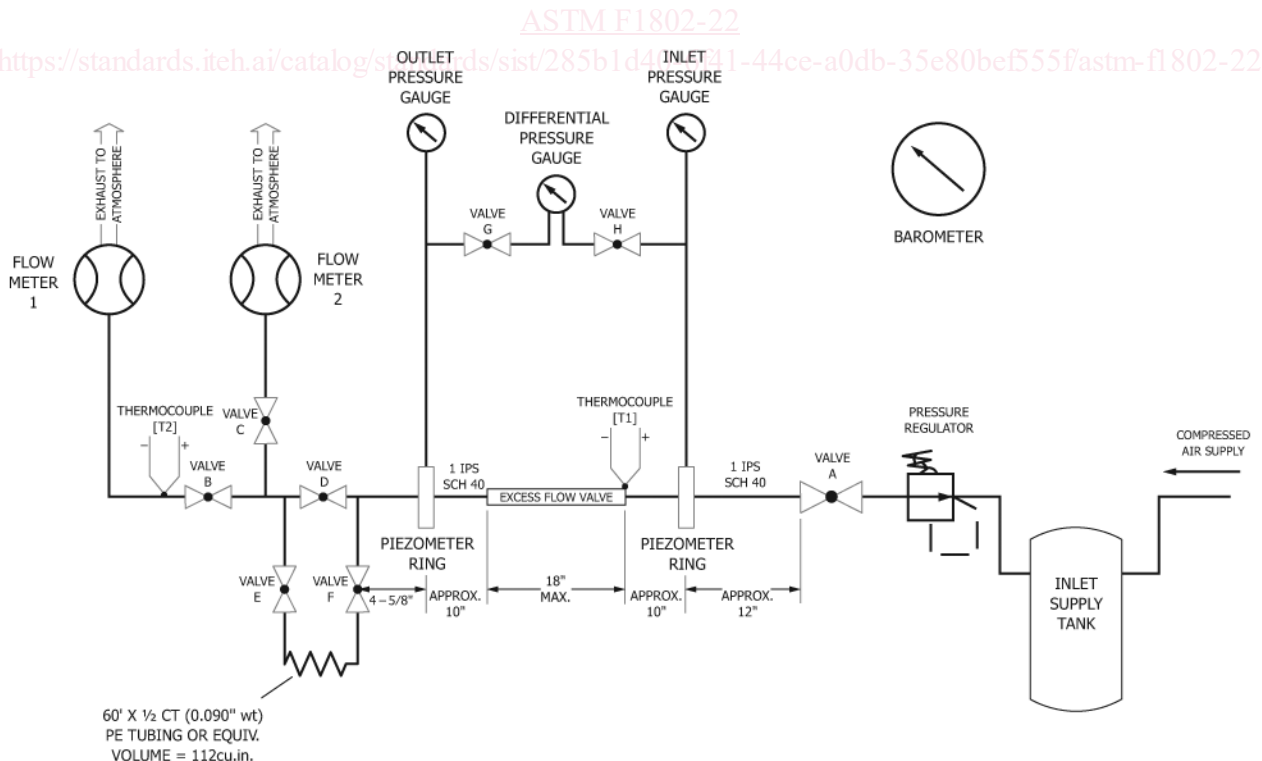

FIG. 1 Test Apparatus For Excess Flow Valves

4.2.3 ~~Pressure Drop at Flow Rates Less than Closure~~—~~Pressure Drop at Flow Rates Less than Closure~~~~after~~—after setting the inlet pressure to the desired value, pressure drop measurements shall be taken at each of the following flow rates that are less than the valve’s minimum closure flow rate: 100, 200, 300, 400, 500, 750, 1000, 1250, and 1500 SCFH (2.8, 5.6, 8.5, 11.32, 14.2, 21.24, 28.3, 35.4, and 42.5 M<sup>3</sup>/h).

4.2.4 ~~Reset~~—~~Reset~~~~Following~~—~~Following~~ the manufacturer’s instructions, verify that the EFV can be reset.

## 5. Significance and Use

5.1 This test method is intended to be used for the evaluation of EFVs manufactured for use on residential and small commercial thermoplastic natural gas service lines. Possible applications of the test include product design and quality control testing by a manufacturer and product acceptance testing by a natural gas utility.

5.2 The user of this test method should be aware that the flows and pressures measured in the test apparatus may not correlate well with those measured in a field installation. Therefore, the user should conduct sufficient tests to ensure that any specific EFV will carry out its intended function in the actual field installation used.

## 6. Apparatus

6.1 ~~Test Apparatus~~—~~Test Apparatus~~, (See Fig. 1) consisting of a compressed air supply, valves, flowmeters, Piezometer rings located at each pressure test point, pressure gages, and thermocouples.

6.1.1 The size and capabilities of the test system should be selected to meet the needs of the application. A test system for EFVs of one size and a single pressure range may be much less sophisticated than one designed for a wide range of sizes and multiple operating pressure ranges.

6.2 ~~Compressed Air Supply System~~: Compressed Air Supply System:

6.2.1 The air supply system shall be able to provide clean dry air at the required test temperature for a time sufficient to obtain a test data point at the highest test pressure and at the maximum flow rate of the EFV being tested. Such a requirement may be met either by a low-volume compressor and a large pressure vessel or by a high-volume compressor and a smaller pressure vessel.

6.2.2 This test method is intended for maximum air flows up to 2500 ft<sup>3</sup>/h (70.8 m<sup>3</sup>/h). However, for many applications, a nominal requirement would be for an air flow of 1000 ft<sup>3</sup>/h (28.32 m<sup>3</sup>/h) at a pressure of 100 psig (0.7 MPa) for a period of 60 s.

6.3 ~~Piezometer Rings~~: Piezometer Rings:

6.3.1 A Piezometer ring shall be used at each pressure test point as shown in Fig. 1.

6.3.2 Piezometer rings are designed to provide a flow-independent measurement of the pressure in a pipe. They are essential in pipes with flowing gas in them. Appendix X1 shows the dimensions for construction of a Piezometer ring.

6.4 ~~Pressure and Differential Pressure Gages~~: Pressure and Differential Pressure Gages:

6.4.1 Each air pressure gage or differential pressure gage shall measure the range of pressures at its location in the test apparatus to an accuracy within  $\pm 2\%$ .

6.4.2 Differential pressure gages shall be rated for pressures above the maximum encountered in the application.

NOTE 1—Do not use “snubs” on pressure gages.

6.5 Flowmeters:

6.5.1 Each flowmeter shall measure the range of flows at its location in the test apparatus to an accuracy within  $\pm 2\%$ , traceable to the National Institute of Standards and Technology. Note that flowmeter accuracy is usually expressed as a percent of the full scale reading. Therefore, to maintain accuracy it is generally advisable to operate the meter at as high a flow as possible.

6.5.2 Each flowmeter shall have manufacturer supplied correction factors for conversion of air flow rates measured at the metering pressure and temperature to corrected flow rates of 0.6 relative density natural gas at standard conditions. Some users have found it convenient to use flowmeters calibrated to measure air, but that indicate flow rates for natural gas.

6.5.3 Flowmeters shall not generate pressure or flow fluctuations in the flowing air stream that could adversely affect either the measurement of these values or the operation of the EFV.

6.5.4 Flowmeters shall be easy to clean and to keep clean.

6.5.5 ~~Flow Control Valve B~~—~~Flow Control Valve B~~This —This valve, as it is moved from full closed to full open, shall be capable of producing a uniformly increasing air flow. An NPS 1 valve such as a full port globe or gate valve or automated flow device have been found satisfactory.

6.5.6 ~~Inlet Valve A, Bypass Valves D, E, F, and Flow Control Valve C~~—~~Inlet Valve A, Bypass Valves D, E, F, and Flow Control Valve C~~These —These shall be full port NPS 1 valves.

6.6 ~~Piping~~—~~Piping~~Using —Using Schedule 40, NPS 1 steel for inlet and outlet piping and associated fittings for the EFV.

6.7 ~~Thermocouple~~—~~Thermocouple~~Two —Three thermocouples are required and shall measure temperature to an accuracy of  $\pm 3^{\circ}\text{F}$  ( $1.7^{\circ}\text{C}$ );  $\pm 3^{\circ}\text{F}$  ( $1.7^{\circ}\text{C}$ ). One shall be installed so as to measure the temperature of the EFV being tested. ~~Two~~One shall be installed in the flowing air stream to measure the temperature immediately upstream of Flowmeter 1, and immediately upstream of the EFV under test.1.

6.8 ~~Temperature Control~~—~~Temperature Control~~The —The apparatus to control test temperature shall be such that the temperature of the EFV (T1) and of the air flow measured by the thermocouple upstream of the flowmeter (T3)(T2) shall be within  $\pm 10^{\circ}\text{F}$  ( $\pm 5.5^{\circ}\text{C}$ ) of  $67^{\circ}\text{F}$  ( $5.5^{\circ}\text{C}$ ) of  $19.4^{\circ}\text{C}$  ( $19.4^{\circ}\text{C}$ ). For testing at  $0^{\circ}\text{F}$  ( $-17.7^{\circ}\text{C}$ )  $0^{\circ}\text{F}$  ( $-17.7^{\circ}\text{C}$ ) and at  $100^{\circ}\text{F}$  ( $37.7^{\circ}\text{C}$ ),  $100^{\circ}\text{F}$  ( $37.7^{\circ}\text{C}$ ), the temperature of the EFV (T1) shall be within  $\pm 10^{\circ}\text{F}$  ( $\pm 5.5^{\circ}\text{C}$ )  $\pm 10^{\circ}\text{F}$  ( $5.5^{\circ}\text{C}$ ) of the test temperature. The test apparatus and test EFV shall be insulated as appropriate so as to maintain the test temperature.

6.9 ~~Reset Volume~~—~~Reset Volume~~A 60 ftA60 ft (18.28 m) long coil of  $\frac{1}{2}$  CTS 0.090 in. ( $\frac{2}{3}$  mm) wall PE tubing or pipe with an equivalent volume of 112 in.<sup>3</sup> ( $1,835\text{ cm}^3$ ) ( $1,835\text{ cm}^3$ ). The inside coil radius shall not be less than 16 in. (406.4 mm) (minimum bend radius = 25 times the outside tube diameter).

## 7. Sample Preparation

7.1 The user of this test method will select the EFV configuration to be tested. However, the configuration will affect the test results. For example, the pressure drop and the trip-flow rate values will be different when the EFV is inserted in a straight length of thermoplastic pipe, as compared to an EFV inserted in the outlet of a thermoplastic punch tee. This must be borne in mind when selecting the sample configuration.

7.2 Any adapters used to install the EFV in the test apparatus shall not restrict the flow to a degree which contributes to the measured pressure drop. In addition, these adapters shall not generate pressure or fluctuations in the flowing air stream that could adversely affect either the measurement of these values or the operation of the EFV. Five samples of each EFV shall be tested in accordance with Section 10.

## 8. Precautions and Safety Considerations

8.1 Test personnel shall be trained in the use and operation of this test apparatus and be familiar with safe use of compressed air. Any outlets or relief vents from the air system should be directed away from the areas occupied by personnel. Face, eye, hand, and hearing protection should be worn as necessary.

## 9. Flow Calculations

9.1 The raw air flow rate data must be converted into an equivalent air flow rate at the calibration conditions, pressure and temperature, of the flow meter. In addition this calculated air flow rate must be corrected to an equivalent natural gas flow rate at standard conditions.

9.2 Flow rate conversions shall be performed using the flow rate correction method provided by the manufacturer of the flow meter. Inlet pressure, barometric pressure, and air stream temperature (~~(T<sub>3</sub>)~~;(T<sub>2</sub>)), must be included in these conversion calculations.

## 10. Procedure

10.1 Prior to performing any test, perform a trial run to adjust the regulator set points and flow control valves at the critical flow rates for improved accuracy. The trip flow tests require preparation and are difficult to perform, since the flow rate is not at steady-state conditions when data must be obtained.

10.1.1 Some other reasons for performing trial test runs are to become more familiar with the test procedures and to ensure that the test system is assembled and functions as intended.

10.1.2 Each test shall be performed at ~~67~~67 °F  $\pm$  40°F (~~19.4~~19.4 °C  $\pm$  5.5°C)5.5 °C), and if desired, at either of the optional test temperatures given in Section 4.

### 10.2 Preliminary Procedure:

10.2.1 *System Cleanliness Inspection* —After the test apparatus, connecting pipe, and sample are assembled, or after significant modifications to the test assembly, the system shall be inspected for visible contaminants. This is accomplished by means of a high-flow purge of the system using the highest anticipated test flow rate. For this inspection, a fine filter with a suitable pressure rating is placed downstream of the EFV location. (A “dummy” EFV may be used to prevent damage to the test sample.) After the purge, disassemble the filter and inspect for visible contamination. If contaminants are present, the system, flow elements, and filter shall be cleaned and the procedure repeated until no contaminants are present.

### 10.2.2 ~~EFV Sample Inspection:~~EFV Sample Inspection:

10.2.2.1 Install the EFV in the test apparatus as shown in Fig. 1, pressurize, and inspect for movement or leakage.

10.2.2.2 Record the manufacturer’s designation and the style or configuration of the EFV tested.

### 10.3 ~~Trip flow:~~Trip flow:

10.3.1 Close all valves.

10.3.2 Set and control the air supply pressure to within  $\pm 2$  % of the desired EFV inlet pressure.

10.3.3 Open Valve D to the full open position.

10.3.4 Open Valve A very slowly to a full open position to prevent overpressure of the device.

10.3.5 Check that the inlet and downstream pressure gages show equal pressure.

10.3.6 Slowly open Valve B while observing Flowmeter 1. Increase the flow rate uniformly from about ~~50~~50 % to 100 % of the trip flow, taking particular care with the speed near the trip point to ensure an accurate reading.

10.3.7 Record the temperature, inlet pressure, and trip flow at the instant trip occurs.

10.3.8 Perform the test five times and record the average trip flow and the maximum and minimum flows.

### 10.4 ~~Bypass Test or Leak Rate Test:~~Bypass Test or Leak Rate Test:

10.4.1 This test is performed similarly on EFVBs and EFVNBs. Flowmeter 2 shall be sized appropriately for the flow being measured. Bypass flows for EFVBs are usually higher than leakage flows for EFVNBs. If a positive displacement meter is used as Flowmeter 2, ensure that sufficient volume is measured to obtain the required accuracy of  $\pm 2$  %.

10.4.2 Perform this test after each activation or trip of the EFV in 10.3.

10.4.3 With the EFV tripped, reset the inlet pressure, open Valve C, and close Valve B.

10.4.4 Measure flow using Flowmeter 2.

10.4.5 Record the inlet pressure, the temperature, and the bypass or leak rate as appropriate.

10.5 ~~Total Pressure Drop~~: Total Pressure Drop:

10.5.1 Close all valves.

10.5.2 Adjust and maintain air supply pressure to the desired value  $\pm 2\%$ .

10.5.3 Open Valve D to the full open position.

10.5.4 Open Valve A slowly to the full open position.

10.5.5 Open Valve B slowly to achieve the desired flow rate, as specified in 4.2.3.

10.5.6 Read the differential pressure gage.

10.5.7 Record the inlet pressure, temperature, the total pressure drop, and the flow rate.

10.5.8 Repeat 10.5.5 through 10.5.8 for the desired applicable flow rates given in 4.2.3.

10.6 ~~System Pressure Drop~~: System Pressure Drop:

10.6.1 To determine the pressure drop of the test piping system, repeat 10.5 with the EFV removed and an equivalent length of 1 IPS pipe installed.

10.6.2 Record the inlet pressure, temperature, pressure drop, and flow rate.

10.7 ~~Reset~~—~~Reset~~—~~Confirm~~Confirm that the EFVB will reset according to the manufacturer's instructions. Record results of the reset test, including inlet pressure and time to reset. When performing this test at temperatures above or below ambient, record the time that the device is exposed to the test temperature before the test begins.

10.7.1 ~~Frip Flow~~: Trip Flow:

10.7.1.1 Close all valves.

10.7.1.2 Perform the trip flow procedure as stated in 10.3.1 to 10.3.6.

10.7.2 With the EFVB tripped, open valves "E" and "F" to add 60 ft (18.28 m) of ½ CTS 0.090 in. (2.3 mm) wall PE tubing, or an equivalent volume of 112 in<sup>3</sup> (1,835 cm<sup>3</sup>) to the flow path.

10.7.3 Close Valve "D" to divert the flow path through the 60 ft (18.28 m) of ½ CTS tubing or an equivalent volume.

10.7.4 Close valve "E" and start a timing device or note the time of the valve closure to the nearest second.

10.7.5 Observe the downstream pressure gage and note the time, in minutes and seconds, when the downstream pressure gage indicates the same pressure as the inlet pressure gage. To verify that the EFVB has reset, open valve "E" slightly and monitor the downstream pressure gage. If the EFBV has not reset the pressure will fall rapidly to zero.

10.7.6 Record results of the reset test, including reset pressure and time to reset. When performing this test at temperatures above or below ambient, record the time that the device is exposed to the test temperature before the test begins.