



Designation: D2265 – 22

Standard Test Method for Dropping Point of Lubricating Grease Over Wide Temperature Range¹

This standard is issued under the fixed designation D2265; the number immediately following the designation indicates the year of original adoption or, in the case of revision, the year of last revision. A number in parentheses indicates the year of last reapproval. A superscript epsilon (ϵ) indicates an editorial change since the last revision or reapproval.

This standard has been approved for use by agencies of the U.S. Department of Defense.

1. Scope*

1.1 This test method covers the determination of the dropping point of lubricating grease.

1.2 **Warning**—The dropping point as measured by this test is an artificially corrected number that does not have any bearing on the performance of the grease at elevated temperature. The dropping point as defined by this test method may not correlate with a value of the dropping point as determined by Test Method D566 (ISO 2176).

1.3 *This test method uses mercury thermometers.* **WARNING**—Mercury has been designated by many regulatory agencies as a hazardous substance that can cause serious medical issues. Mercury, or its vapor, has been demonstrated to be hazardous to health and corrosive to materials. Use caution when handling mercury and mercury-containing products. See the applicable product Safety Data Sheet (SDS) for additional information. The potential exists that selling mercury or mercury-containing products, or both, is prohibited by local or national law. Users must determine legality of sales in their location. The responsible subcommittee, D02.G0.03, continues to explore alternatives to eventually replace the mercury thermometers.

1.4 *This standard does not purport to address all of the safety concerns, if any, associated with its use. It is the responsibility of the user of this standard to establish appropriate safety, health, and environmental practices and determine the applicability of regulatory limitations prior to use.*

1.5 *This international standard was developed in accordance with internationally recognized principles on standardization established in the Decision on Principles for the Development of International Standards, Guides and Recommendations issued by the World Trade Organization Technical Barriers to Trade (TBT) Committee.*

¹ This test method is under the jurisdiction of ASTM Committee D02 on Petroleum Products, Liquid Fuels, and Lubricants and is the direct responsibility of Subcommittee D02.G0.03 on Physical Tests.

Current edition approved April 1, 2022. Published April 2022. Originally approved in 1964. Last previous edition approved in 2020 as D2265 – 20. DOI: 10.1520/D2265-22.

2. Referenced Documents

2.1 *ASTM Standards:*²

D217 Test Methods for Cone Penetration of Lubricating Grease

D566 Test Method for Dropping Point of Lubricating Grease
D3244 Practice for Utilization of Test Data to Determine Conformance with Specifications

E1 Specification for ASTM Liquid-in-Glass Thermometers

E2251 Specification for Liquid-in-Glass ASTM Thermometers with Low-Hazard Precision Liquids

2.2 *ISO Standards:*³

ISO 2176 Petroleum products – Lubricating grease – Determination of dropping point

3. Terminology

3.1 *Definitions:*

3.1.1 *lubricating grease, n*—a semi-fluid to solid product of a thickener in a liquid lubricant.

3.1.1.1 *Discussion*—The dispersion of the thickener forms a two-phase system and immobilizes the liquid lubricant by surface tension and other physical forces. Other ingredients are commonly included to impart special properties. **D217**

3.1.2 *thickener, n*—in lubricating grease, a substance composed of finely-divided particles dispersed in a liquid to form the product's structure.

3.1.2.1 *Discussion*—Thickeners can be fibers (such as various metallic soaps) or plates or spheres (such as certain non-soap thickeners), which are insoluble or, at most, only very slightly soluble in the liquid lubricant. The general requirements are that the solid particles be extremely small, uniformly dispersed, and capable of forming a relatively stable, gel-like structure with the liquid lubricant. **D217**

3.2 *Definitions of Terms Specific to This Standard:*

² For referenced ASTM standards, visit the ASTM website, www.astm.org, or contact ASTM Customer Service at service@astm.org. For *Annual Book of ASTM Standards* volume information, refer to the standard's Document Summary page on the ASTM website.

³ Available from International Organization for Standardization (ISO), ISO Central Secretariat, BIBC II, Chemin de Blandonnet 8, CP 401, 1214 Vernier, Geneva, Switzerland, http://www.iso.org.

*A Summary of Changes section appears at the end of this standard

3.2.1 *dropping point, n*—a numerical value assigned to a grease composition representing the corrected temperature at which the first drop of material falls from the test cup and reaches the bottom of the test tube.

3.2.1.1 *Discussion*—In the normal and proper operation of this test method, the observed dropping point is corrected by adding to it a value representing one third of the difference between the oven block temperature and the observed dropping point temperature. This corrected value is recorded as the dropping point of the grease. This is not the same definition for dropping point that is used in Test Method D566.

3.2.2 *observed dropping point, n*—the value noted on the thermometer monitoring the internal temperature of the grease test cup when the first drop of material falls from the test cup and reaches the bottom of the test tube.

4. Summary of Test Method

4.1 A grease sample in a grease test cup is supported in a test tube placed in an aluminum block oven at a preset constant temperature. A sample thermometer is placed in the tube and so positioned that it measures the temperature in the sample cup without coming in contact with the grease.

4.2 As the temperature increases, at some point a drop of material will fall from the cup to the bottom of the test tube. The reading on the sample thermometer is recorded to the nearest degree as the observed dropping point. At the same time, the temperature of the aluminum block oven is also recorded to the nearest degree.

4.3 One third the difference between the two values is the correction factor which is added to the observed value and recorded as the dropping point of the grease.

5. Significance and Use

5.1 The dropping point is useful to assist in identifying the grease as to type and for establishing and maintaining bench marks for quality control. The results are to be considered to have only limited significance with respect to service performance of conventional soap thickeners because dropping point is a static test. Above 200 °C, the dropping point has no correlation with the maximum upper operating temperature of the grease.

5.2 Historical cooperative testing⁴ on conventional soap-thickened greases indicated (RR:D02-1164) that, in general, dropping points by Test Method D2265 and Test Method D566 were in agreement up to 200 °C. In cases where results differ, there is no known significance. However, agreement between the manufacturer and purchaser as to test method used is advisable.

6. Apparatus

6.1 *Dropping Point Assembly* (Fig. 1) consisting of the following:

6.1.1 *Grease Cup*, chromium-plated brass cup conforming to the dimensions shown in A, Fig. 1.

6.1.2 *Test Tube*, thin walled, soft glass test tube with rim, having dimensions shown in B, Fig. 1.

6.1.3 *Cup Support*, glass tubing as shown in C, Fig. 1.

6.1.4 *Thermometer*, thermometer 3C as prescribed in Specification E1 and shown in D, Fig. 1.

6.1.5 *Accessories*, thermometer clamp as shown in E-1, bushings as shown in E-2 and E-3, bushing support ring as shown in E-4, thermometer depth gage as shown in E-5, a metal rod as shown in E-6, and cup gage as shown in E-7, all of Fig. 1.

6.2 *Aluminum Block Oven*, aluminum block oven of the design and dimensions shown in Fig. 2. The block shall be equipped with an integral cartridge-type heater. Control of the current to the heater shall be used to obtain and maintain the desired oven temperature.

6.2.1 *Aluminum Block Oven Thermometer*, conforming to thermometer with specified immersion line equal to depth of thermometer well in accordance with Specifications E1 or E2251, such as thermometer 3C.

7. Sampling

7.1 The sample presented for analysis should be large enough to make possible the selection of a representative portion for testing. Examine for any indication of non-homogeneity such as oil separation, phase changes, or gross contamination. If any abnormal conditions are found, obtain a new sample.

8. Preparation of Apparatus

8.1 Thoroughly clean the cup, cup support, and test tube with mineral spirits. (Warning—Flammable. Vapor harmful.)

8.2 Use only cups that are clean and free of any residue. When the interior plating of the cup shows indications of wear, discard.

8.3 When new cups are to be used, check their dimensions by using the cup plug gage (E-7 of Fig. 1). To check the bottom opening of the cup a 2.78 mm rod should fit easily while a 2.82 mm rod should not.⁵ If the hole is undersize, ream to the correct size. If too large, discard. Cups of the proper dimensions need not be rechecked before each test run.

8.4 Test tubes shall be clean and free of residues and conform to the dimensions shown in B, Fig. 1. Inspect for chips or cracks and replace when necessary.

8.5 Sample thermometer bulb shall be clean and free of residues. Inspect bushings for cleanliness and be certain the thermometer clamp, E-1, Fig. 1, is sufficiently tight to hold the thermometer in position.

8.6 The glass sleeve used to support the cup shall be free of any cracks or chips, residue or stain, and conform to the dimensions shown in C, Fig. 1. Replace when necessary.

⁴ Supporting data have been filed at ASTM International Headquarters and may be obtained by requesting Research Report RR:D02-1164. Contact ASTM Customer Service at service@astm.org.

⁵ These are commonly available as a 7/64-in. drill and a No. 34 drill, respectively.

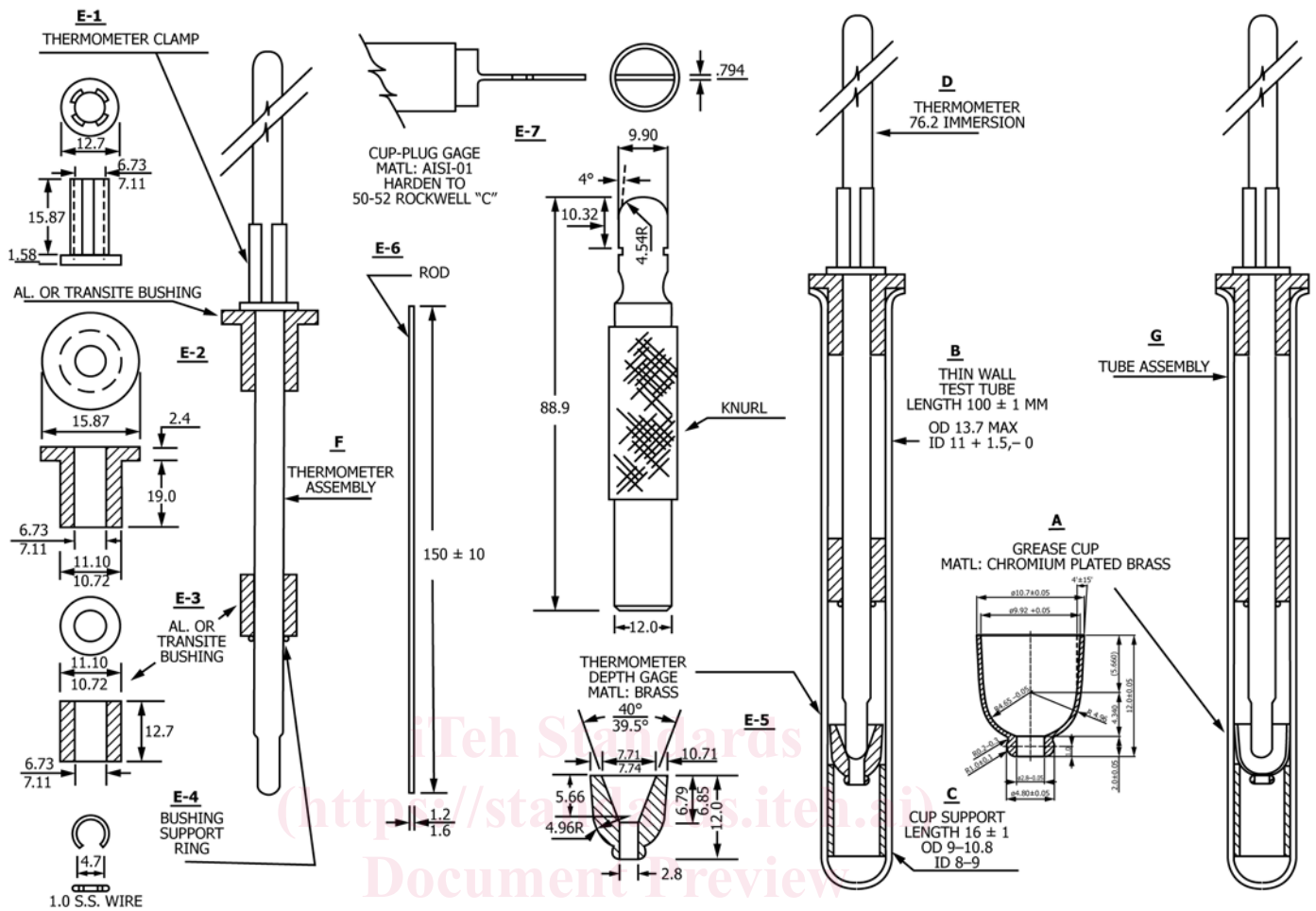

(a) Dimensions in millimetres.

FIG. 1 Apparatus for Dropping Point Test of Lubricating Grease

9. Procedure

9.1 Insert empty test tubes in every test tube well and a thermometer having a range from -5 °C to 400 °C in the thermometer well of the oven.

9.2 Turn on the oven and select the lowest aluminum block oven temperature setting from the four listed below that will result in an observed dropping point at or below the corresponding maximum observed dropping point shown for that oven temperature setting.

Oven Temperature, °C	Maximum Observed Dropping Point, °C
121 ± 3	116
232 ± 3	221
288 ± 3	277
316 ± 3	304

9.3 Select and use test tubes and accessories E-1, E-2, and E-3 to minimize wobble of the thermometer. All components must be at room temperature prior to the test. Place the components E-1 through E-4 on the thermometer in the order shown by the thermometer assembly (F) Fig. 1. Adjust the bushing E-3 and the bushing support ring E-4 so that E-4 is

about 25 mm from the tip of the thermometer. Place the cup support C in tube B. Insert the thermometer depth gage E-5 and the thermometer assembly in the tube. Position the thermometer so that the tip bottoms in the gage. Adjust the bushing E-2 and the thermometer clamp E-1 so that the bushing shoulders on the top edge of the tube.

9.4 Select a clean cup, and fill it with grease either by pushing the cup into the sample presented or by using a small spatula. Overfill the cup, and use the spatula to force some of the grease out of the bottom hole of the cup to help remove any trapped air. Add more sample, and strike off the excess grease level with the top of the cup. Gently press the cup, held in a vertical position with the smaller opening at the bottom, down over the metal rod E-6, Fig. 1, until the latter protrudes about 25 mm. Press the rod against the cup in such a manner that the rod makes contact at both the upper and lower peripheries of the cup. Maintain this contact, rotating the cup on the rod along the index finger to give it a spiral-like motion down the rod to remove a conical section of the grease which adheres along the rod. As the cup approaches the end of the rod, carefully slip the rod out of the cup, without marring the inside surface of the grease, so that a smooth film of reproducible thickness remains

DROPPING POINT APPARATUS

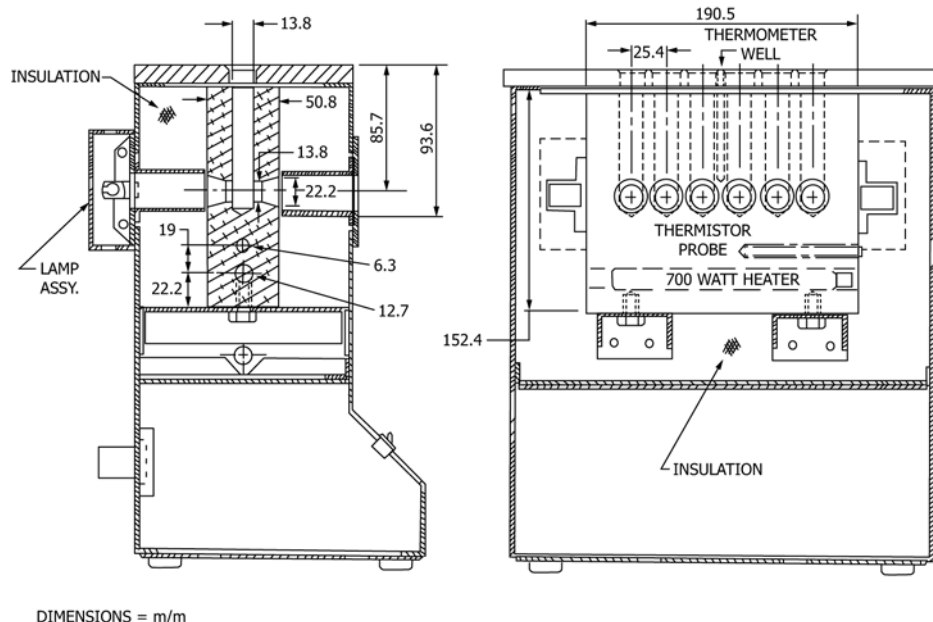

FIG. 2 Aluminum Block Oven

DIMENSIONS = m/m

inside the cup. If the surface has been touched by the rod or any air bubbles are noted, repack the cup. See Fig. 3.

9.5 Remove the thermometer assembly and depth gage from the tube. Place the grease cup on the cup support in the test tube and carefully reinsert the thermometer assembly. Make no further adjustment as the thermometer bulb is now positioned to provide adequate clearance between the tip of the bulb and grease sample in the cup.

9.6 After making certain that the oven temperature has stabilized, remove an empty tube from the oven and gently insert the tube assembly, G, (Fig. 1) in its place. Exercise care to ensure that the cup remains upright in the cup support. If the cup is tilted, the thermometer bulb can come in contact with the film of grease and result in an erroneous value.

9.7 When the first drop of material falls free of the cup orifice and reaches the bottom of the test tube, record both the temperature of the cup and of the oven to the nearest degree. Certain greases, for example, some simple soap compositions, or those containing some types of polymers can form a drop with a tailing thread which can hold until the drop reaches the bottom of the test tube. The temperature in the cup when the drop reaches the bottom of the test tube is recorded as the observed dropping point.

NOTE 1—The aluminum block oven can accommodate up to six samples of the same or different greases so that multiple determinations can be made simultaneously.

10. Calculation

10.1 Calculate the dropping point as follows:

$$DP = ODP + [(BT - ODP)/3]$$

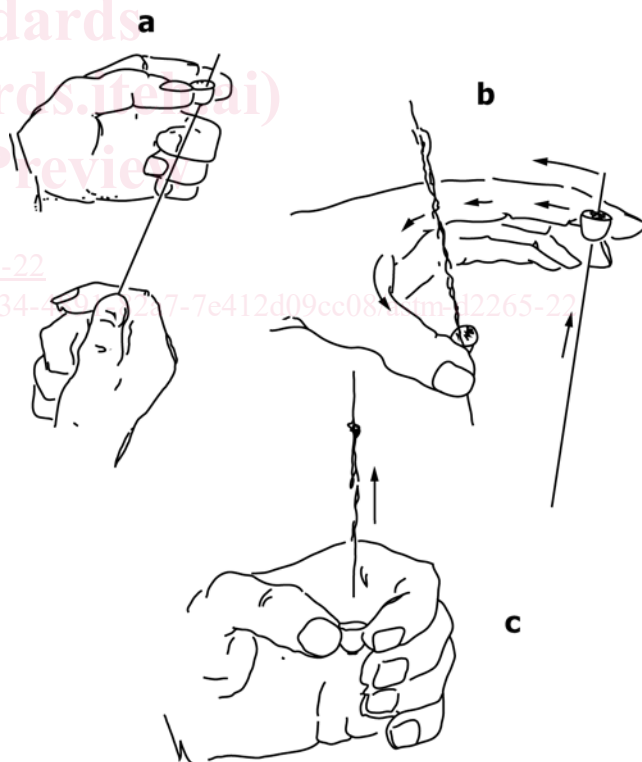

FIG. 3 Technique for Filling Grease Cup

where:

- DP = dropping point,
- ODP = thermometer reading when first drop reaches the bottom of the test tube, and
- BT = block temperature when the drop falls.