



Designation: ~~D1683/D1683M – 17 (Reapproved 2018)~~ D1683/D1683M – 22

Standard Test Method for Failure in Sewn Seams of Woven Fabrics¹

This standard is issued under the fixed designation D1683/D1683M; the number immediately following the designation indicates the year of original adoption or, in the case of revision, the year of last revision. A number in parentheses indicates the year of last reapproval. A superscript epsilon (ϵ) indicates an editorial change since the last revision or reapproval.

This standard has been approved for use by agencies of the U.S. Department of Defense.

INTRODUCTION

The structural integrity of textile products made of woven fabrics is dependent on how well the pieces that are cut from rolls of fabric have been joined together. To measure this integrity requires understanding the inter-relationship between two distinct test methods.

(a) The first evaluation is done by testing fabric using Test Method **D5034**. This standard is used to measure the resistance of a woven fabric to rupture in the warp direction and, the filling yarn direction. The test method measures the force needed to rupture the fabric causing the destruction of the fabric and the loss of its structural integrity. This loss of structural integrity causes yarn slippage, that is, the displacement and change of yarn spacing causing an irreversible fabric failure.

(b) Before completing the second evaluation, an analysis and determination of the anticipated failure mode needs to be completed by the fabric weaver or textile product manufacturer. While the failure mode for a woven fabric textile product sewn seam can demonstrate various and distinct levels, it is imperative to have agreement and understanding about the expected performance or service life of the end use product. Is the seam engineering used to build the textile product intended to perform for a “single incident” discarded and replaced, or is the end use product designed and engineered to be subjected to regular care and maintenance to include repairs?

(c) The second evaluation is done by using this test method, D1683/D1683M, to test fabric sections that have been cut and then sewn together using procedures that select a specific combination of sewing thread, stitch type, seam type, and stitch density. These are the seam engineering variables that determine which of the following outcomes can occur: (1) the fabric, at a force similar to that when tested using Test Method **D5034**, will rupture adjacent to the stitch line causing the destruction and loss of fabric integrity, and the failure of the textile structure; (2) the sewing thread used in the specific stitch configuration will rupture, at a force less than 85 % of the fabric break strength, such that the fabric integrity will be sufficient to enable repair of the textile structure along the same axis.

1. Scope

1.1 This test method measures the sewn seam strength in woven fabrics by applying a force perpendicular to the sewn seams.

1.1.1 The axis perpendicular to the sewn seam can represent either the warp yarn axis or filling yarn axis, the same axis tested when using grab Test Method **D5034**.

1.1.1.1 This test method is applicable to sewn seams obtained from a previously sewn article or seams sewn with fabric samples using one of two specific seam assemblies as shown in **Table 1**.

1.2 This test method is used when the maximum breaking force measurement to rupture of a woven fabric sewn seam is required.

¹ This test method is under the jurisdiction of ASTM Committee **D13** on Textiles and is the direct responsibility of Subcommittee **D13.54** on Subassemblies. Current edition approved March 15, 2018/April 1, 2022. Published April 2017/April 2022. Originally approved in 1990. Last previous edition approved in 2017 as D1683-17 ϵ 1-(2018). DOI: 10.1520/D1683-D1683M-17R18-10.1520/D1683-D1683M-22.

TABLE 1 Standard/Default Seam Assembly Specification^A

Fabric Mass: $\leq 4 \text{ oz/yd}^2$ [130 g/m ²]		
Mass	Procedure A up to 4 oz/yd ² [130 g/m ²]	Procedure B up to 4 oz/yd ² [130 g/m ²]
Seam allowance	13 mm [0.5 in.]	13 mm [0.5 in.]
Needle:		
Size	Metric 90 [0.036 in.]	Metric 90 [0.036 in.]
Finish	chrome	chrome
Point	thin ball (No. 1/No. 23)	thin ball (No. 1/No. 23)
Sewing thread size:		
Spun Polyester	Tex 40	Tex 40
Polyester-Core	Tex 40	Tex 40
Seam Type	Ssa-1	Ssa-1
Stitch Type	301	401
Stitch Density	4.7 \pm 1/2 stitches per centimetre [12 \pm 1/2 stitches per inch]	4.7 \pm 1/2 stitches per centimetre [12 \pm 1/2 stitches per inch]
Fabric Mass: $> 4 \text{ oz/yd}^2$ [130 g/m ²] $\leq 8 \text{ oz/yd}^2$ [270 g/m ²]		
Mass	Procedure A 4 oz/yd ² [130 g/m ²] up to 8 oz/yd ² 270 g/m ²	Procedure B 4 oz/yd ² [130 g/m ²] up to 270 g/m ² [8 oz/yd ²]
Seam Allowance	13 mm [0.5 in.]	13 mm [0.5 in.]
Needle:		
Size	Metric 110 [0.044 in.]	Metric 110 [0.044 in.]
Finish	chrome	chrome
Point	ball	ball
Sewing Thread:		
Spun Polyester	Tex 60	Tex 60
Polyester-Core	Tex 60	Tex 60
Seam type	SSa-1	SSa-1
Stitch type	301	401
Stitch density	3.1 \pm 1/2 stitches per centimetre [8 \pm 1/2 stitches per inch]	3.1 \pm 1/2 stitches per centimetre [8.5 \pm 1/2 stitches per inch]
Fabric Mass: $> 8 \text{ oz/yd}^2$ [270 g/m ²] $\leq 12 \text{ oz/yd}^2$ [405 g/m ²]		
Mass	8 oz/yd ² [270 g/m ²] up to 12 oz/yd ² [405 g/m ²]	8 oz/yd ² [270 g/m ²] up to 12 oz/yd ² [405 g/m ²]
Seam allowance	13 mm [0.5 in.]	13 mm [0.5 in.]
Needle:		
Size	Metric 120	Metric 120
Finish	chrome	chrome
Point	ball	ball
Sewing thread size:		
Spun Polyester	Tex 80	Tex 80
Polyester-Core	Tex 80	Tex 80
Seam type	Ssa-1	SSa-1
Stitch type	301	401
Stitch density	3.1 \pm 1/2 stitches per centimetre [8 \pm 1/2 stitches per inch]	3.1 \pm 1/2 stitches per centimetre [8.5 \pm 1/2 stitches per inch]

^A A complete description of seam types and stitch types can be found in Practice D6193.473c-a02d-66c646459316/astm-d1683-d1683m-22

NOTE 1—When the performance of a woven textile structure requires data to indicate the maximum seam strength that will result in the failure of fabric on either side of seam, the standard seam can be changed to use the Lapped seam type construction with two or more rows of stitching: Lsc-2; Lsc-3; Lsc-4; and the maximum number of stitches per inch that can be used. (See Practice D6193.)

1.2.1 This test method is used when the seam efficiency measurement of a woven fabric sewn seam is required.

1.2.2 This test method is used to identify the sewn seam strength threshold at which the failure of the stitching occurs, without damage to the fabric, so that the textile product can be repaired.

1.2.3 This test method is used to identify the force at which seam strength results in slippage and displacement of warp yarns, filling yarns, or any combination of these yarns.

1.3 This test method does not predict actual wear performance of a seam.

1.4 The values stated in either SI units or inch-pound units are to be regarded separately as standard. The values stated in each system may not be exact equivalents; therefore, each system shall be used independently of the other. Combining values from the two systems may result in non-conformance with the standard.



1.5 This standard does not purport to address all of the safety concerns, if any, associated with its use. It is the responsibility of the user of this standard to establish appropriate safety, health, and environmental practices and determine the applicability of regulatory limitations prior to use.

1.6 This international standard was developed in accordance with internationally recognized principles on standardization established in the Decision on Principles for the Development of International Standards, Guides and Recommendations issued by the World Trade Organization Technical Barriers to Trade (TBT) Committee.

2. Referenced Documents

2.1 ASTM Standards:²

- D76 Specification for Tensile Testing Machines for Textiles
- D123 Terminology Relating to Textiles
- D1776 Practice for Conditioning and Testing Textiles
- D5034 Test Method for Breaking Strength and Elongation of Textile Fabrics (Grab Test)
- D6193 Practice for Stitches and Seams
- D7722 Terminology Relating to Industrial Textile Stitches and Seams
- E177 Practice for Use of the Terms Precision and Bias in ASTM Test Methods
- E691 Practice for Conducting an Interlaboratory Study to Determine the Precision of a Test Method

3. Terminology

3.1 Definitions:

3.2 The following terms are relevant to this standard: needle damage; seam allowance; seam assembly; seam efficiency; seam engineering; seam failure; seam slippage; seam type; sewn seam; sewn seam strength; slippage; standard seam; stitch; stitch density; stitch gage; stitch type; yarn slippage.

3.3 For terminology related to seams and stitched, see Terminology D7722.

3.4 For definitions of other textile terms used in this test method, refer to Terminology D123.

4. Summary of Test Method

4.1 Sewn fabric sections are placed in a test machine so that an applied force, perpendicular to the stitching, can be exerted until one of the following phenomena occur:

4.1.1 Failure of sewing thread stitchline without damage to fabric (sewn seam strength) (seam efficiency).

4.1.2 Failure caused by a force sufficient to stress the sewn seam and displace one or more fabric yarns from their original position so as to cause fabric failure due to difference in alignment, spacing, or both.

5. Significance and Use

5.1 The manufacturing of textile products uses seam engineering to determine the best combination of sewing thread, stitch type, seam type, and stitch density to construct the end use structure. These four seam engineering variables contribute to a textile product being able to achieve the maximum sewn seam strength performance and structural integrity when cut pieces of fabric are joined together.

5.1.1 It is known that for some textile structures the seam engineering variables are selected to meet a “one time performance requirement.” This means that following the “single incident” during which the maximum performance potential or capability of the textile structure has been met, it is expected to be discarded and replaced with another “new” unit. For example: an inflatable restraint in an automobile. Once deployed, it must be replaced; it cannot be re-used. Likewise, there are other textile structures, intended to be used multiple times, while also being subjected to various care and maintenance regimens.

² For referenced ASTM standards, visit the ASTM website, www.astm.org, or contact ASTM Customer Service at service@astm.org. For *Annual Book of ASTM Standards* volume information, refer to the standard’s Document Summary page on the ASTM website.



5.1.2 This test method enables the fabric producer of woven fabrics, the textile producer, and other users of the test method to determine which seam engineering choices can be made relative to: sewing thread tex size; seam type; stitch type; and stitch density to determine the potential outcomes that can occur when a particular woven fabric is used:

- (a) What is the maximum force at which sewn seam strength failure will enable products made with this fabric to be repaired?
- (b) What is the highest seam efficiency percentage attained?
- (c) What is the maximum force at which the sewn seam strength results in seam slippage that can cause yarn slippage, yarn displacement and fabric failure?

5.1.2.1 The maximum force at which sewn seam strength or the highest seam efficiency retained demonstrate failure of the stitching without causing the displacement of one or more fabric yarns from their original position mean that the product can be repaired. When the failure results in displacement of yarns, the textile product will need to be replaced.

5.1.3 The procedures used in this test method represent two primary seam engineering techniques identified in Practice D6193 and used to manufacture products made of woven textile fabrics.

5.1.4 In case of dispute arising from differences in reported test results when using this test method for acceptance testing of commercial shipments, the purchaser and the supplier should perform comparative tests to determine if there is a statistical bias between their laboratories. Competent statistical assistance is recommended for the investigation of bias. As a minimum, the two parties should take a group of test specimens from the same lot of fabric to be evaluated, which utilize a like seam assembly (or standard seam assembly). The test specimens should then be randomly assigned in equal numbers to each laboratory for testing. If a bias is found, either its cause must be determined and corrected, or the purchaser and supplier must agree to interpret future test results in light of the known bias.

5.2 This test method can be used to determine the sewn seam strength and sewn seam efficiency of a specified critical sewn seam assembly assemblies with each fabric. Because sewn seam strength and sewn seam efficiency varies with each fabric, both of the standard seam assemblies, noted in Table 1, should be used when comparing the seam strength of different fabrics. Table 1 lists the default seam assembly specifications to be used for fabrics made with fine, low, medium and heavy count yarns. high density yarn counts. If a determination cannot be made as to which seam is the best suited for a particular fabric, all should be evaluated.

5.3 Seams prepared for this test method should be made by competent factory sewing operators familiar with the potential for damage to the integrity of the sewn seam when stitching is improperly done.

5.3.1 If competent factory sewing operators are not accessible, a laboratory technician familiar with the potential for damage of an improperly sewn seam may prepare the seamed test specimens. It is imperative for purchaser/supplier to understand the impact an improperly sewn seam will have on test results.

5.4 This test method is applicable whenever a determination of sewn seam strength is required. The breaking force of the seam and fabric will permit estimation of seam efficiency. This test method can be used as an aid for estimating seam strength for any given fabric.

5.5 Seam engineering techniques for specific fabric types can also be determined by utilizing this test method.

5.6 This test method can be used to determine when the sewn seam is affected by seam slippage. While the ultimate consequence of this phenomenon is rupture, seam slippage greater than either the values stated in customer specifications, or as agreed upon by purchaser/supplier may severely reduce the integrity such that the product cannot be used for its intended purpose.

6. Apparatus

6.1 *Tensile Testing Machine*, as used in Test Method D5034 conforming to Specification D76, and preferably a constant-rate-of-extension (CRE) type of machine capable of jaw separation rate of $305 \text{ mm/min} \pm 10 \text{ mm/min}$ [$12.0 \text{ in./min} \pm 0.5 \text{ in./min}$] and an interfaced computer response to record the force-extension curve. When a CRE type of machine is not used, a constant-rate-of-traverse (CRT) type of machine may be used. (See Note 1.)

NOTE 1—In cases of dispute a constant-rate-of-extension (CRE) type machine should be used to referee testing. Because of the biases between test results for these types of tensile testing machine, report the name, type and date of calibration of the machine used.



6.1.1 At least one clamp should be supported by a free swivel or universal joint to allow the clamp to rotate in the plane of the fabric.

6.1.2 *Back Jaw*, faces measuring $25 \text{ mm} \pm 1 \text{ mm}$ [$1 \text{ in.} \pm 0.04 \text{ in.}$], parallel to direction of force application by not less than $50 \text{ mm} \pm 1 \text{ mm}$ [$2 \text{ in.} \pm 0.04 \text{ in.}$] perpendicular to direction of force application.

6.1.2.1 Front (or top) faces measuring $25 \text{ mm} \pm 1 \text{ mm}$ by $50 \pm 1 \text{ mm}$ [$1.0 \text{ in.} \pm 0.04 \text{ in.}$ by $2.0 \text{ in.} \pm 0.04 \text{ in.}$] will not necessarily give the same value as $25 \text{ mm} \pm 1 \text{ mm}$ by $25 \pm 1 \text{ mm}$ [$1.0 \text{ in.} \pm 0.04 \text{ in.}$ by $1.0 \text{ in.} \pm 0.04 \text{ in.}$] faces. For many materials, the former are preferable because of the larger gripping area which tends to reduce slippage. While both sizes of gripping surface are permitted, the face sizes used must be the same for all samples in the test and must be recorded in the report.

6.1.3 *Front Jaw*, faces measuring $25 \text{ mm} \pm 1 \text{ mm}$ by $25 \pm 1 \text{ mm}$ [$1 \text{ in.} \pm 0.04 \text{ in.}$ by $1 \text{ in.} \pm 0.04 \text{ in.}$].

6.2 *Sewing Machine*, with any necessary accessories capable of handling the test fabric and forming the required seam(s) and stitch types.

6.3 *Sewing Threads*, to be either of required type, materials, and tex size as determined by purchaser and supplier, or of the type, materials, and tex size specified for standard seams in **Table 1**.

6.4 *Dividers*, one pair.

6.5 *Metal Rule*, graduated in 1 mm [0.03125 in.] 1 mm [0.03125 in.] subdivisions.

7. Sampling Manufactured Items

7.1 Specimens can be taken from either previously sewn seam or from structures made with sewn seams as noted in **Table 1**, or using a seam assembly as agreed to between purchaser and supplier.

7.2 *Lot Sample for Manufactured Items*—As a lot sample for acceptance testing, take at random, the number of shipping units of manufactured items containing sewn seams as directed in a material specification or other agreement between the purchaser and the supplier.

7.2.1 An adequate specification or other agreement between the purchaser and supplier requires taking into account the variability between cartons of previously manufactured items or rolls of fabric from which sewn seam will be prepared; and between specimens from a carton of manufactured items or prepared constructions to produce a sampling plan with a meaningful producer's risk and consumer's risk, while at the same time providing acceptable quality and limited quality levels.

7.3 *Laboratory Sample for Manufactured Items*—Take sufficient manufactured items from each carton of a lot sample as to provide adequate laboratory samples and adequate specimens for each assembly being evaluated. If more than one type of seam assembly exists in the laboratory samples, the choice of seam assembly to be evaluated must be agreed upon by the purchaser and supplier.

7.4 *Test Specimens from Manufactured Items*—Cut five test specimens for each specified seam assembly in each of the warp and fill directions (where applicable) from the specified manufactured item(s) in the laboratory sample. Cut each specimen to a total length of $350 \text{ mm} \pm 3 \text{ mm}$ [$14 \text{ in.} \pm 0.1 \text{ in.}$] perpendicular to the proposed seam, with $250 \text{ mm} \pm 3 \text{ mm}$ [$10 \text{ in.} \pm 0.1 \text{ in.}$] on one side of the seam and $100 \text{ mm} \pm 3 \text{ mm}$ [$4 \text{ in.} \pm 0.1 \text{ in.}$] on the opposite site of the seam, and a width of $100 \text{ mm} \pm 3 \text{ mm}$ [$4 \text{ in.} \pm 0.1 \text{ in.}$] parallel to the stitch line(s) of the seam. (See **Fig. 1**.) If the required number of specimens cannot be cut from each laboratory sampling unit or if there is more than one seam in the laboratory sampling units, modify the sampling plan as agreed between the supplier and purchaser.

7.4.1 When the specimen length of $350 \text{ mm} \pm 3 \text{ mm}$ [$14 \text{ in.} \pm 0.1 \text{ in.}$] is not attainable so as to provide sufficient length of fabric perpendicular to the seam, to allow adequate seam strength testing and fabric strength testing, a modification must be agreed to between purchaser and supplier. A comparison of the fabric break strength as determined by Test Method **D5034**, of the two fabric swatches used in the seaming to the sewn strength of the seam assembly is required to produce a value indicative of the seam efficiency.

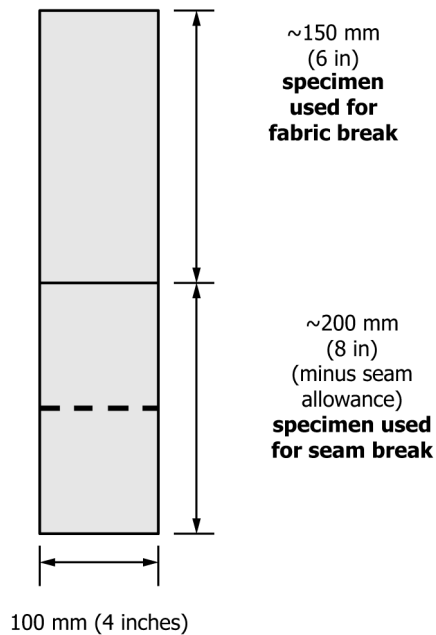

FIG. 1 Seamed Specimen Removed from Manufactured Item

8. Sampling of Seams Prepared from Fabric

8.1 *Lot Sample for Fabric*—As a lot sample for acceptance testing, take at random the number of rolls of fabric directed in an applicable material specification or other agreement between the purchaser and supplier.

8.2 *Laboratory Sample for Fabric*—After discarding $1 \text{ m} \pm 0.1 \text{ m}$ [$1 \text{ yd} \pm 0.1 \text{ yd}$] from the outside roll, take a swatch $3 \text{ m} \pm 0.1 \text{ m}$ [$3 \text{ yd} \pm 0.1 \text{ yd}$] in length and the full width of the fabric to construct an adequate quantity of the seam assembly, which is to be evaluated.

8.2.1 *Specimen Preparation*—As a source of test specimens, cut five specimens $350 \text{ mm} \pm 3 \text{ mm}$ [$14 \text{ in.} \pm 0.1 \text{ in.}$] by $100 \text{ mm} \pm 3 \text{ mm}$ [$4 \text{ in.} \pm 0.1 \text{ in.}$] with their long dimensions parallel either to the warp (machine) direction or to the filling (cross) direction, or cut specimens for testing from both directions if required. (See Fig. 2.) Preferably specimens for a given fabric direction should be spaced along a diagonal of the fabric to allow for representation of different warp and filling yarns, or machine and cross direction areas, in each specimen. When possible, filling specimens should contain yarn from widely separated filling areas. Unless otherwise specified, take specimens no nearer to the selvage, or edge of the fabric, than one tenth of the width of the fabric. Depending on the direction in which seam strength is to be tested, sew swatch as follows:

8.2.2 Fold the specimen $100 \text{ mm} \pm 3 \text{ mm}$ [$4 \text{ in.} \pm 0.1 \text{ in.}$] from one end with the fold parallel to the short direction of the fabric. Sew a seam as agreed upon by purchaser and supplier. (See Fig. 3.)

8.2.2.1 In the absence of an agreement on the construction of a seam assembly, prepare a standard seam using the specifications from Table 1. These seam assembly specifications are categorized by fabric weight, as shown in Table 1. These default seam assemblies are to be used when production seams are not available, or specified.

8.2.3 After seaming, cut the fold open. The test specimen should contain a seam approximately $100 \text{ mm} \pm 3 \text{ mm}$ [$4 \text{ in.} \pm 0.1 \text{ in.}$] from one end. Each test specimen will contain sufficient material for one seamed and one fabric test. (See Fig. 1.)

8.2.3.1 Yarns parallel to direction of force, and perpendicular to the seam, when tested, indicate seam strength test direction.

8.2.3.2 When preparing sewn seams to be evaluated for failure, it is suggested that distinct colors of sewing thread be used to easily identify warp direction ruptures and filling direction ruptures.

8.3 Modifications to seam sample preparation are detailed in Annex A1 and Annex A2. These modifications can be used when a

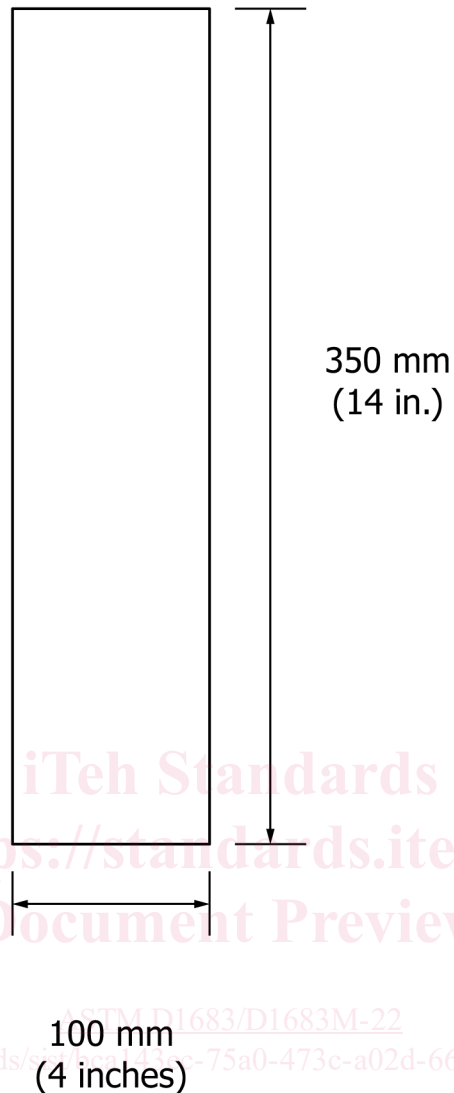

iTeh Standards
(<https://standards.iteh.ai>)
Document Preview

<https://standards.iteh.ai/catalog/standards/sist/bca1433c-75a0-473c-a02d-66c646459316/astm-d1683-d1683m-22>

FIG. 2 Cut Specimen Dimension from Fabric

determination is made about the acceptable failure mode for the textile structure. Will the failure mode be measured as a single incident or is the structure expected to be repaired?

8.3.1 Changes to be made in tex size of sewing thread, seam type, and stitch density are explained and calculations shown.

8.3.2 The determination of an acceptable failure mode – either a single incident or a textile structure able to be repaired, is a determination that can be made by either fabric weaver or textile structure producer.

9. Conditioning

9.1 Condition the specimens by bringing them from the dry side to approximate moisture equilibrium for testing in the standard atmosphere for testing textiles as directed in Practice **D1776**. Equilibrium is considered to have been reached when the increase in mass of the specimen in successive weighings made at intervals of not less than 2 ± 0.1 h does not exceed 0.1 % of the mass of the specimen.

10. Procedure

10.1 *Seam Strength Procedure A:*

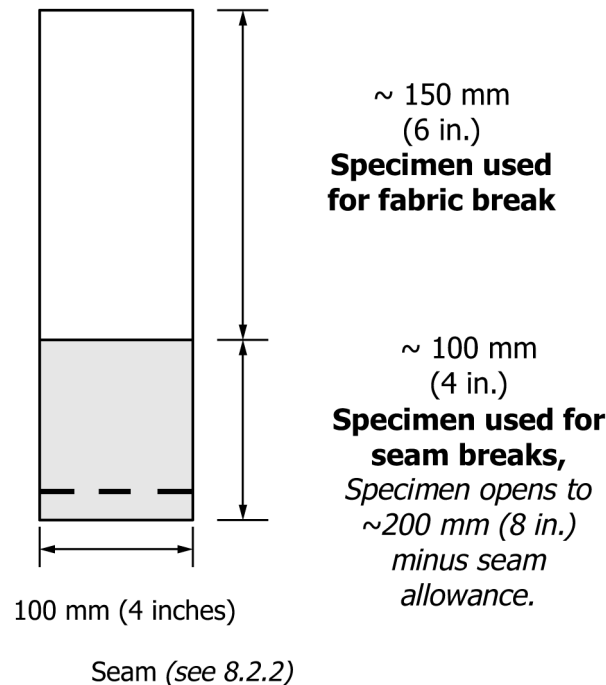

FIG. 3 Seamed Specimen Dimensions Prepared from Fabric

10.1.1 This procedure is used to measure when the stress created by a specific sewn seam can result in the displacement of one or more fabric yarns from their original position so as to cause differences in alignment, spacing, or both.

10.1.2 Using the reported grab break strength results when fabric is tested using Test Method [D5034](#), calculate the 85 % seam efficiency in both the warp yarn direction and filling yarn direction.

10.1.2.1 Multiply the reported grab break strength results, starting at 85 % and continue to 70 % by increments of 5 %. These results can be used to estimate sewn seam strength and sewn seam efficiency percentages using a default seam engineering combination of sewing thread, stitch type, seam type and stitch density detailed in [Table 1](#), Procedure A or the modifications detailed in [Annex A1](#) and [Annex A2](#).

10.1.3 Test five specimens in both directions, perpendicular to warp yarns and perpendicular to filling yarns, to determine if the standard seam used in this procedure will result in the displacement of one or more fabric yarns from their original position and cause a difference in alignment, spacing, or both. When this failure mode occurs, continue testing after modifying one of the following:

10.1.3.1 Change either the sewing thread tex size or stitch density and complete calculation in either [Annex A1](#) or [Annex A2](#) to include using either a single row or multiple rows of stitching, and test five specimens in both directions perpendicular to warp yarns and perpendicular to filling yarns to determine if failure results in the displacement of one or more fabric yarns. Report these changes.

10.1.4 Report when the failure mode is a rupture of the stitching without causing any displacement of fabric yarns or difference in alignment.

10.1.4.1 Compare the results to the estimated seam strength calculated in [10.1.2](#).

10.1.5 Report the seam efficiency percentage at which the sewn seam rupture occurs without causing yarn displacement of one or more fabric yarns.

10.2 Seam Strength Test Procedure B:

10.2.1 This procedure is used to measure when the stress created by a specific sewn seam can result in the displacement of one or more fabric yarns from their original position so as to cause differences in alignment, spacing, or both.

10.2.2 Using the reported grab break strength results when fabric is tested using Test Method D5034, calculate the 85 % seam efficiency in both the warp yarn direction and filling yarn direction.

10.2.2.1 Multiply the reported grab break strength results, starting at 85 % and continue to 70 % by increments of 5 %. These results can be used to estimate sewn strength and sewn seam efficiency percentages using default seam engineering combination of sewing thread, stitch type, seam type and stitch density detailed in Table 1, Procedure B or the modifications detailed in Annex A1 and Annex A2.

10.2.3 Test five specimens in both directions, perpendicular to warp yarns and perpendicular to filling yarns, to determine if the standard seam used in this procedure will result in the displacement of one or more fabric yarns from their original position and cause a difference in alignment, spacing, or both. When this failure mode occurs, continue testing after modifying one of the following:

10.2.3.1 Change either the sewing thread tex size or stitch density, complete the calculation in either Annex A1 or Annex A2 to include using either a single row or multiple rows of stitching, and test five specimens in both directions perpendicular to warp yarns and perpendicular to filling yarns to determine if failure results in the displacement of one or more fabric yarns. Report these changes.

10.2.4 Report when the failure mode is a rupture of the stitching without causing any displacement of fabric yarns or difference in alignment.

10.2.4.1 Compare the results to the estimated seam strength calculated in 10.2.2.

10.2.5 Report the seam efficiency percentage at which the sewn seam rupture occurs without causing yarn displacement of one or more fabric yarns.

10.3 All Sewn Seam Samples—Specimens are cut from samples to achieve specimen size shown in Fig. 4.

10.3.1 Determine the stitch density by counting the stitches per centimetre [stitches per inch].

10.3.2 With the fabric in the open front position (as shown in Fig. 4) place the specimen into the clamp with the seam line centrally located between the clamp faces and perpendicular to the pulling force.

10.4 Fabrics Tested Using Modified Grab Break (see Annex A2):

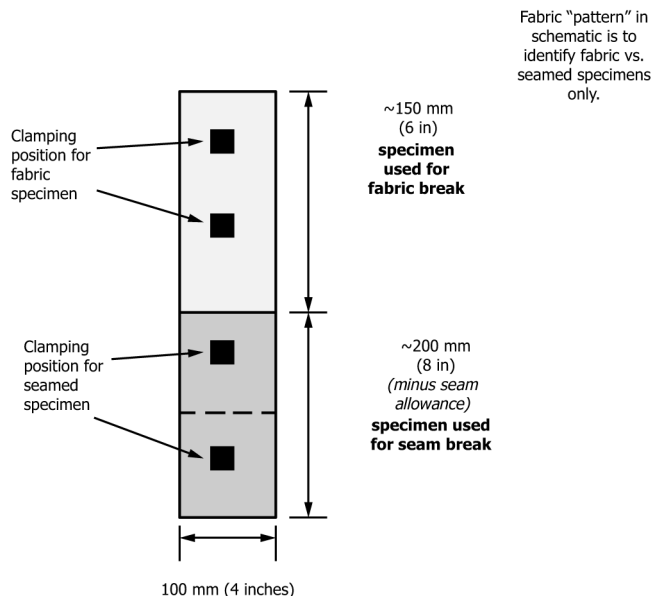

FIG. 4 Seamed Specimen Removed from Manufactured Item

10.4.1 Fabrics tested using the modified grab break procedure demonstrate higher grab break strength.

10.4.1.1 **Annex A2** provides additional data that can be used to select sewing thread having break strength needed to reach the higher seam strength needed to evaluate these fabrics. Sewn seam strength achieved with these higher grab break strength fabrics require using sewing threads made of high performance fibers to meet the traditional seam efficiency ratios of 80 – 85 %.

10.4.1.2 Purchaser and supplier should agree on either the sewn seam strength or the sewn seam efficiency needed for the textile structure subsequent to evaluation of results using this test method.

10.5 To aid in placing specimens into the testing machine, it is recommended to draw vertical alignment guides perpendicular to the stitch line $40\text{ mm} \pm 3\text{ mm}$ [$1.5\text{ in.} \pm 0.1\text{ in.}$] from both edges. For matched top and bottom jaws of equal width, measuring from the edge to perpendicular lines drawn on the specimen can ensure proper placement in the clamps. (See **Fig. 5**.)

10.6 *Machine Set-up Conditions*—Adjust the distance between the clamps at the start of the test at $75\text{ mm} \pm 3\text{ mm}$ [$3\text{ in.} \pm 0.1\text{ in.}$]. (See **Fig. 5**.) Select the force range of testing machine so that break occurs between 10 and 90 % of full-scale force.

10.7 *Sewn Seam Strength and Seam Slippage*—To calculate seam slippage, the load versus displacement curve for the sewn seam must be compared to the load versus displacement curve for the fabric. (See **Fig. 6**.)

10.7.1 Computerized software programs are available from various tensile testing equipment manufacturers. Although these programs are available to testing facilities, it is imperative that the laboratory operators/technicians fully understand the test parameters used in the calculations for both sewn seam strength and seam slippage.

10.7.2 During application of the force to the sewn seam specimen, observe and record whether the seam rupture is caused by (1) fabric yarn rupture, (2) sewing thread rupture, (3) sewn seam yarn slippage, or (4) a combination of two or more of the foregoing.

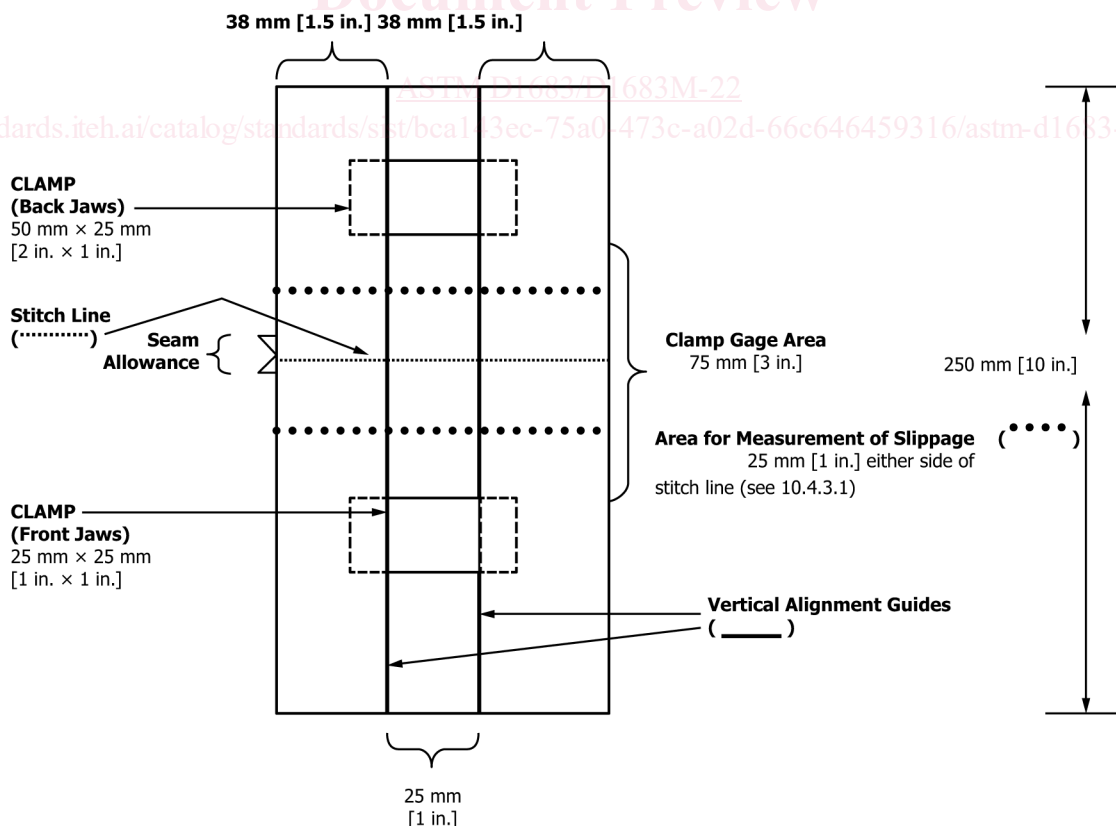
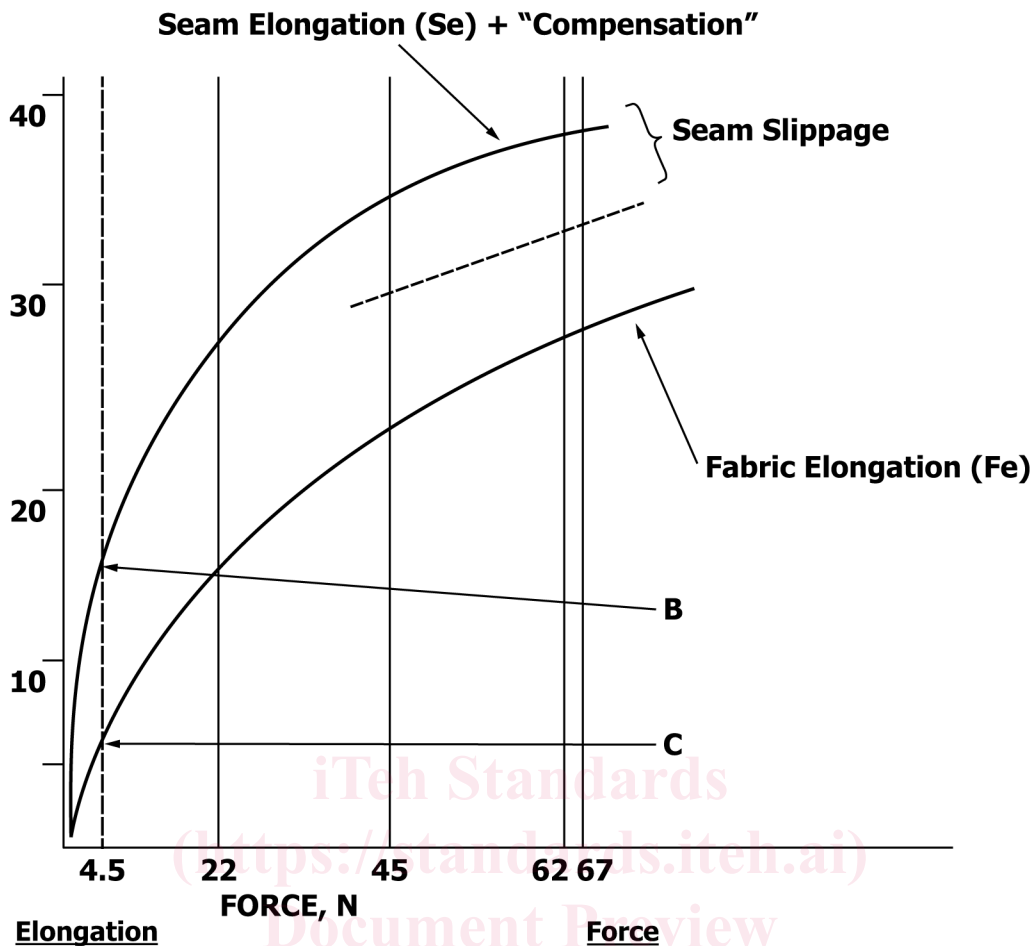

FIG. 5 Seamed Specimen Placement in Clamps



25 mm = 1 in. (0.984 in.)	4.5 N = 1 lbf (1.01 lbf)
50 mm = 2 in. (1.967 in.)	22 N = 5 lbf (4.95 lbf)
1 inch = 25 mm (25.4 mm)	45 N = 10 lbf (10.12 lbf)
2 inch = 50 mm (50.84 mm)	62 N = 14 lbf (13.94 lbf)
	67 N = 15 lbf (15.06 lbf)

FIG. 6 Seam Slippage Chart

10.7.3 For measurement of seam elongation, prepare a force-elongation chart, having the curve set separated for each specimen and the starting point on a zero ordinate and corresponding abscissa.

10.7.4 Ensure that no clamp slippage occurs during the test. There are several options available to check for clamp slippage, an example of which follows: Distinction between clamp slippage and fabric slippage within the specimen can be determined by measuring the elongation of the intermediate space between the upper and lower limits of the clamp gauge area. (See Fig. 5.)

10.7.4.1 Measure two points $25 \text{ mm} \pm 3 \text{ mm}$ [$1.0 \text{ in.} \pm 0.1 \text{ in.}$] both above and below stitch line and (1) draw parallel lines, (2) attach a device which measures elongation either mechanically or electronically, and (3) record the change in length between these two lines.

10.7.5 Note the actual time of break for the first three specimens. If the time of break for these specimens is within $20 \pm 3 \text{ s}$, do not determine the time of break for the remaining specimens and do not report the average time of break. If the time of break for the first three specimens is outside $20 \pm 3 \text{ s}$, determine the time of break for each specimen and report the average time of break.

10.7.5.1 If the average of the three tests meets the time criterion set up, these observations shall be part of the number of tests. Record and report separately the test results in either warp or filling directions.