



Designation: B615 – 79 (Reapproved 2022)

# Standard Practice for Measuring Electrical Contact Noise in Sliding Electrical Contacts<sup>1</sup>

This standard is issued under the fixed designation B615; the number immediately following the designation indicates the year of original adoption or, in the case of revision, the year of last revision. A number in parentheses indicates the year of last reapproval. A superscript epsilon ( $\epsilon$ ) indicates an editorial change since the last revision or reapproval.

## 1. Scope

1.1 This practice describes the practices and factors considered to be most important in the measurement of electrical contact noise of sliding contacts.

1.2 *This standard does not purport to address all of the safety concerns, if any, associated with its use. It is the responsibility of the user of this standard to become familiar with all hazards including those identified in the appropriate Safety Data Sheet (SDS) for this product/material as provided by the manufacturer, to establish appropriate safety, health, and environmental practices, and determine the applicability of regulatory limitations prior to use.*

1.3 *This international standard was developed in accordance with internationally recognized principles on standardization established in the Decision on Principles for the Development of International Standards, Guides and Recommendations issued by the World Trade Organization Technical Barriers to Trade (TBT) Committee.*

## 2. Terminology

### 2.1 Definitions:

2.1.1 *contact noise, n*—the varying voltage across a pair of electric contacts due to conditions at their interface. It is to be distinguished from the variation of signal due to its transmission through electrical conductors (that is, induced voltages due to adjacent sources). It is also to be distinguished from acoustic noise which may be generated by the contact action.

2.1.1.1 *Discussion*—Stepwise change of resistance of a wirewound potentiometer due to the definite resistance of a single turn is not electrical contact noise.

2.1.2 *switching or edge noise, n*—the electrical contact noise occurring during the period of transition from conduction to non-conduction (or vice versa) of a switching device.

<sup>1</sup> This practice is under the jurisdiction of ASTM Committee B02 on Nonferrous Metals and Alloys and is the direct responsibility of Subcommittee B02.05 on Precious Metals and Electrical Contact Materials and Test Methods.

Current edition approved April 1, 2022. Published April 2022. Originally approved in 1979. Last previous edition approved in 2017 as B615 – 79 (2017). DOI: 10.1520/B0615-79R22.

## 3. Significance and Use

3.1 Resistance or voltage values alone do not provide sufficient detail for an engineering evaluation of contact noise. This practice lists the test conditions that should be reported with noise measurements and indicates some conditions (open circuit voltages, currents, etc.) that have been used for quality control and research studies. The use of these practices should provide sufficient detail for an engineering interpretation of the noise data and allow the tests to be repeated by another laboratory.

## 4. Types of Testing

4.1 *Type I*—Qualification and acceptance testing of electro-mechanical devices when low electrical contact noise is important for proper functioning.

4.1.1 Electrical and mechanical parameters should closely simulate the end use of the device.

4.1.2 Since the procedure is used as a method of quality control, the test parameters must be duplicated each time the test is conducted.

4.2 *Type II*—Measurement of contact voltage variation as a method of studying tribological phenomena.

4.2.1 Tests are designed with specific diagnostic or research goals.

4.2.2 Electrical and mechanical parameters are based on considerations of basic contact physics and not the engineering requirements of the device. Selected parameters may be varied as part of the test. For example, rotational rate of a slip ring may be varied to determine the surface velocity at which hydrodynamic lift becomes important.

## 5. Test Conditions

5.1 The following test conditions should be controlled or known to enable adequate evaluation of test results:

### 5.1.1 Electrical Parameters:

5.1.1.1 *Current*—Contact current and waveform should be specified. The limitations of the instrument(s) being used to measure the noise and adequacy of shielding from extraneous noise sources must be considered when current level is chosen. Type I tests may be made either at current levels chosen to simulate those required in actual use or may be at higher current levels in order to enhance test sensitivity provided any

such higher current magnitude shall be agreed upon between the device user and producer (Note 1).

5.1.1.2 *Source Voltage*—The maximum open-circuit voltage (to the contacts) and the impedance of the source should be specified. In Type I tests, the open-circuit voltage levels chosen should simulate those required in actual use and may be at more than one level if representative of the end use (Note 1). In Type II tests, any voltage levels may be used depending on the objectives of the studies being made (Note 2).

NOTE 1—A current of 100 mA from a constant-current (d-c) source with a 6-V maximum open-circuit voltage is often used for Type I testing of miniature slip ring-brush units intended for use in inertial guidance systems.

NOTE 2—In Type II tests, one must consider the softening, melting, and arc-sustaining voltages of the contacts being tested. Also, if it is not desirable to frit (electrically puncture) organic or oxide surface films, an open-circuit voltage of 20 mV or less must be used.

5.1.1.3 *Load*—The impedance of the load should be defined. Capacitive and inductive loads may affect the observed contact noise.

5.1.1.4 *Circuit Arrangement*—When multiple circuits are to be tested on a sliding contact device the arrangement of the circuits should be defined (for example, single circuit, pairs, multiple circuits in series). Circuit pairs are often monitored for Type I tests. Type II tests will often be conducted on single sets of contacts since fundamental interpretations are simpler.

5.1.1.5 *Detector Characteristics*—The type of detector should be defined along with its input impedance, resistance, and frequency response.

5.1.1.6 *Shielding*—The entire circuit must be electrically shielded to prevent pickup of stray noise from nearby equipment or power lines which will introduce erroneous results. All mechanical apparatus must be well grounded. The baseline noise should be recorded while the contacts are static. This value should be negligible when compared to the noise measured from the operating contacts.

5.1.2 *Mechanical Parameters:*

5.1.2.1 *Contact Surface Velocity*—Since the dynamics of the contacts are dependent upon the surface velocity, it should be defined for any test.

5.1.2.2 *Wipe Rate*—The frequency of wiping across any specified point of the contact surface should be defined. More frequent wipes disperse films and lubricants, while less frequent wiping allows film formation which may cause contact noise.

5.1.2.3 *Special Conditions*—Additional description may be necessary to define the mode of operation completely (for example, amplitude and frequency of oscillation, duty cycle, reversal of direction).

5.1.3 *Environmental Conditions:*

5.1.3.1 *Temperature of Test*—Temperature should be specified and held within specific limits.

5.1.3.2 *Lubrication*—Lubrication of the contacts should be held constant to allow duplication of test. The type, thickness, and method of lubricant application requires control.

5.1.3.3 *Gaseous Environment*—Conditions should be defined as completely as possible. At least a designation such as “laboratory atmosphere,” “closed glass chamber,” or “enclosed with drive motor,” should be included in the test description.

6. Apparatus and Techniques

6.1 *Peak (-to-Peak) Instantaneous Noise* (decreasing frequency capability):

- 6.1.1 *Oscilloscope.*
- 6.1.2 *Optical Recorder.*
- 6.1.3 *Peak-Reading Voltmeter.*
- 6.1.4 *D’Arsonval Recorder.*
- 6.1.5 *Servo Recorder.*

6.2 *RMS Noise:*

- 6.2.1 *True RMS Voltmeter.*
- 6.2.2 *Average to RMS Converting Voltmeter.*
- 6.2.3 *Servo Recorder.*

6.3 *Special Techniques:*

- 6.3.1 *Pulse Count*, at specific level or levels.
- 6.3.2 *Pulse Duration*, at specific level or levels.
- 6.3.3 *Spectrum Analysis.*
- 6.3.4 *Power Spectral Density.*
- 6.3.5 *Missing Pulse Count.*
- 6.3.6 *Pulse Alteration* (phase, amplitude).
- 6.3.7 *Transient Recorder.*

7. Sampling

7.1 The sampling plan should be as mutually agreed by the producer and user of the electromechanical device. Many assemblies (for example, slip ring capsules for inertial guidance platforms) are 100 % tested.

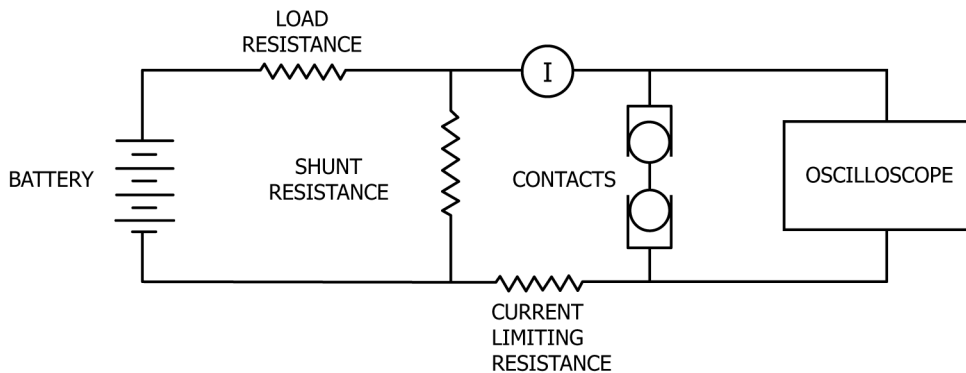

FIG. 1 Circuit Diagram