



Standard Specification for Drawers, Furniture, Marine, Steel¹

This standard is issued under the fixed designation F825; the number immediately following the designation indicates the year of original adoption or, in the case of revision, the year of last revision. A number in parentheses indicates the year of last reapproval. A superscript epsilon (ϵ) indicates an editorial change since the last revision or reapproval.

1. Scope

1.1 This specification covers the construction of steel furniture drawers for use where invoked by other marine furniture specifications.

1.2 This specification applies to all furniture drawers, except items requiring progressive drawers.

1.3 The values stated in inch-pound units are to be regarded as standard. The values given in parentheses are mathematical conversions to SI units that are provided for information only and are not considered standard.

1.4 *This international standard was developed in accordance with internationally recognized principles on standardization established in the Decision on Principles for the Development of International Standards, Guides and Recommendations issued by the World Trade Organization Technical Barriers to Trade (TBT) Committee.*

2. Referenced Documents

2.1 *ASTM Standards:*²

A240/A240M Specification for Chromium and Chromium-Nickel Stainless Steel Plate, Sheet, and Strip for Pressure Vessels and for General Applications

A1008/A1008M Specification for Steel, Sheet, Cold-Rolled, Carbon, Structural, High-Strength Low-Alloy, High-Strength Low-Alloy with Improved Formability, Required Hardness, Solution Hardened, and Bake Hardenable

A653/A653M Specification for Steel Sheet, Zinc-Coated (Galvanized) or Zinc-Iron Alloy-Coated (Galvannealed) by the Hot-Dip Process

D907 Terminology of Adhesives

¹ This specification is under the jurisdiction of ASTM Committee F25 on Ships and Marine Technology and is the direct responsibility of Subcommittee F25.03 on Outfitting and Deck Machinery.

Current edition approved April 1, 2022. Published April 2022. Originally approved in 1983. Last previous edition approved in 2017 as F825 – 93 (2017). DOI: 10.1520/F0825-22.

² For referenced ASTM standards, visit the ASTM website, www.astm.org, or contact ASTM Customer Service at service@astm.org. For *Annual Book of ASTM Standards* volume information, refer to the standard's Document Summary page on the ASTM website.

2.2 *AISC Manual:*³

AISC Wire and Sheet Metal Gauges Equivalent Thickness in Decimals of an Inch, for Uncoated Hot and Cold Rolled Sheets

3. Terminology

3.1 *Definitions of Terms Specific to This Standard:*

3.1.1 *drawers*—storage units in furniture items that have tracks on the sides to allow the drawer to slide open or closed.

3.1.2 *tracks*—the supporting assembly, attached to the sides of a drawer, that allows a drawer to slide open or closed.

3.1.3 *drawer tracks*—that portion of the track assembly that is attached to drawer sides.

3.1.4 *case track*—that portion of the track assembly that is attached to side of supporting furniture (case) item.

4. Ordering Information

4.1 Drawers are included as part of the orders for items of furniture requiring drawers. These orders shall include the following:

4.1.1 *Paint:*

4.1.1.1 *Color*—Drawers shall be painted to match the furniture item in which they are installed.

4.1.1.2 Manufacturer's standard baked enamel will be furnished unless otherwise required and indicated by the purchaser.

4.1.2 Locks, if required, shall be installed where noted in the ordering documents.

5. Materials and Manufacture

5.1 For typical design, see Fig. 1.

5.2 *Joining:*

5.2.1 *Metal Components of Drawers*, shall be joined by welding or gluing with a structural adhesive as defined in Terminology D907.

5.2.2 Joining shall be adequate to prevent racking during handling.

³ Available from American Institute of Steel Construction (AISC), 130 E. Randolph St., Suite 2000, Chicago, IL 60601-6219, <http://www.aisc.org>.

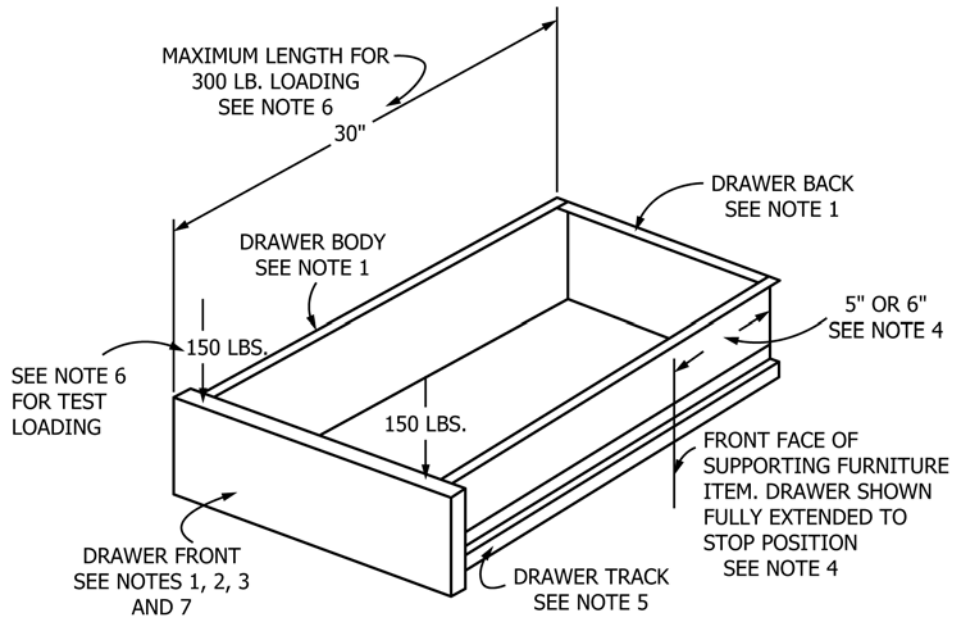

NOTE 1—Drawer front, body, and back shall be a minimum of 0.032 in. (0.81 mm) in accordance with Specification A1008/A1008M.

NOTE 2—Drawers shall be furnished with a means for pulling drawers open.

NOTE 3—Drawers shall incorporate a positive latch to prevent drawers from opening in heavy seas. See 5.6 and Note 7 below.

NOTE 4—Drawers shall be equipped with a means for stopping the drawer in the fully extended position. In this fully extended position, the drawer shall project into the supporting furniture unit no more than 6 in. (152.4 mm) for drawers 20 in. (508 mm) long and over and 5 in. (127 mm) for drawers less than 20 in. (508 mm).

NOTE 5—Drawer and case track shall be zinc-coated steel in accordance with Specification A653/A653M and a minimum of 0.042 in. (1.06 mm). They shall be equipped with antifriction devices, such as nylon buttons, on horizontal bearing surfaces to minimize friction.

NOTE 6—See 6.1 for drawer test-loading requirements.

NOTE 7—See 6.2 for drawer tilt test requirements.

FIG. 1 Furniture Drawers

5.2.3 *Spotwelds*, shall be spaced approximately 3 in. (76 mm) on centers.

5.2.4 *Visible Spotwelds*, on the exterior face of drawer front, higher than the general surface of the metal, shall be ground flush.

5.2.5 *Visible Spotweld Depressions*, on the exterior face of drawer front, shall be spot filled and sanded flush.

5.3 *Drawer Front*, body and back a minimum of 0.032 in. (0.81 mm) in accordance with Specification A1008/A1008M.

5.4 *Drawer Locks*, if required, shall be disk tumbler cam locks having 90° rotation with a screw-on or spun-on cap attachment. Cylinders shall be die-cast zinc with exposed surfaces finished in satin nickel-plated US-15 finish.

5.5 *Drawers*, shall be equipped with a means for stopping the drawer at fully extended position. In this fully extended position, the drawer shall project into the supporting furniture unit no more than 6 in. (152 mm) for drawers 20 in. (508 mm) long and over and 5 in. (127 mm) for drawers less than 20 in. (508 mm).

5.6 All drawers shall incorporate a latch or other positive means to prevent drawers opening in heavy seas. Spring, bullet, magnetic, or bayonet-type catches will not be permitted. Furniture drawers shall not open when the furniture unit in which drawer is installed is tilted a maximum of 30° from the vertical with a drawer load of 30 lb (14 kg).

5.7 All drawers shall be furnished with a means for pulling drawers open.

5.8 *Drawer and Case Tracks*:

5.8.1 Each drawer shall have a pair of drawer tracks with one drawer track on each of its sides. The supporting furniture (case) shall incorporate case tracks on each side to support drawer track.

5.8.2 Drawer and case tracks shall be zinc-coated steel in accordance with Specification A653/A653M, a minimum of 0.042 in. (1.06 mm).

5.8.3 Drawer and case tracks shall be equipped with anti-friction devices, such as nylon buttons, on all horizontal bearing surfaces to minimize friction.

6. Performance Requirements

6.1 *Load Requirement*:

6.1.1 Unless otherwise specified, all drawers 30 in. and below (762 mm and below) in length shall safely support a load of 300 lb (136 kg). The load requirement does not apply to drawers with lengths over 30 in. (over 762 mm).

6.1.2 These loads shall be applied to the front edge of the drawer, with the drawer fully extended to the drawer stop position. Load shall remain on drawer for 3 min.

6.1.3 This test shall not adversely affect the operation of the drawer, and no indication of permanent set shall exist after