



Standard Specification for Tops, Furniture, Marine, Steel¹

This standard is issued under the fixed designation F826; the number immediately following the designation indicates the year of original adoption or, in the case of revision, the year of last revision. A number in parentheses indicates the year of last reapproval. A superscript epsilon (ϵ) indicates an editorial change since the last revision or reapproval.

1. Scope

- 1.1 This specification covers the construction of steel furniture tops for use where invoked by other marine furniture specifications.
- 1.2 This specification applies to tops for furniture case goods only such as chests of drawers, log desks with cabinets, and so forth.
- 1.3 The values stated in inch-pound units are to be regarded as standard. The values given in parentheses are mathematical conversions to SI units that are provided for information only and are not considered standard.

1.4 This international standard was developed in accordance with internationally recognized principles on standardization established in the Decision on Principles for the Development of International Standards, Guides and Recommendations issued by the World Trade Organization Technical Barriers to Trade (TBT) Committee.

2. Referenced Documents

2.1 ASTM Standards:²

- ~~A366/A366M/A1008/A1008M~~ Specification for ~~Commercial Steel (CS) Sheet, Carbon, (0.15 Maximum Percent) Cold-Rolled Steel, Sheet, Cold-Rolled, Carbon, Structural, High-Strength Low-Alloy, High-Strength Low-Alloy with Improved Formability, Required Hardness, Solution Hardened, and Bake Hardenable (Withdrawn 2000)~~
- B16/B16M Specification for Free-Cutting Brass Rod, Bar and Shapes for Use in Screw Machines
- B221 Specification for Aluminum and Aluminum-Alloy Extruded Bars, Rods, Wire, Profiles, and Tubes
- D907 Terminology of Adhesives

2.2 NEMA Specification:³

- ANSI/NEMA LD-3 High Pressure Decorative Laminates

2.3 AISC Manual:⁴

- AISC Wire and Sheet Metal Gauges Equivalent Thickness in Decimals of an Inch, U.S. Standard Gauge (USSG) for Uncoated Hot and Cold Rolled Sheets

2.4 ANSI Standard:⁵

- A208.1 American National Standard for Mat Formed Particle Board

¹ This specification is under the jurisdiction of ASTM Committee F25 on Ships and Marine Technology and is the direct responsibility of Subcommittee F25.03 on Outfitting and Deck Machinery.

Current edition approved Jan. 1, 2017/April 1, 2022. Published January 2017/April 2022. Originally approved in 1983. Last previous edition approved in 2010 as F826 – 94 (2017). DOI: 10.1520/F0826-94R17.10.1520/F0826-22.

² For referenced ASTM standards, visit the ASTM website, www.astm.org, or contact ASTM Customer Service at service@astm.org. For Annual Book of ASTM Standards volume information, refer to the standard's Document Summary page on the ASTM website.

³ Available from National Electrical Manufacturers Association (NEMA), 1300 N. 17th St., Suite 900, Arlington, VA 22209, http://www.nema.org.

⁴ Available from American Institute of Steel Construction (AISC), 130 E. Randolph St., Suite 2000, Chicago, IL 60601-6219, http://www.aisc.org.

⁵ Available from American National Standards Institute (ANSI), 25 W. 43rd St., 4th Floor, New York, NY 10036, http://www.ansi.org.

3. Terminology

3.1 Definitions of Terms Specific to This Standard:

- 3.1.1 *case goods*—furniture items having drawers, a cabinet with doors, or both.
- 3.1.2 *edge binder*—the strips of metal or other material applied to the edges of a top.
- 3.1.3 *lee rails*—extensions above the surface of furniture tops that retain items placed on top.
- 3.1.4 *substrate material*—the core, or structural material of the top, to which the melamine laminate is directly bonded.
- 3.1.5 *tops*—the horizontal surface that makes up the upper exposed surface of furniture items.

4. Classification

4.1 Tops shall be of the following types as required by the specifications for the item of furniture and as indicated in the ordering documents. See Fig. 1, Fig. 2, Table 1, and Table 2 for details.

- 4.1.1 *Type I*—Top on which the edge binder is flush with the top and the substrate material is steel.
- 4.1.2 *Type II*—Top on which the edge binder projects above the upper surface of the top to act as a lee rail and the substrate material is steel.
- 4.1.3 *Type III*—Top on which a lee rail is applied to the upper surface of the finished top, the top has a self edge securely bonded to the finished top, and the substrate material is a particle or mineral board core.
- 4.1.4 *Type IV*—Top is an insert panel and the edge binder is an integral part of the supporting furniture unit.
 - 4.1.4.1 *Grade 1*—Substrate material and edge reinforcements for Types I, II, and IV Grade 1 tops shall be a minimum of ± 6 USSG (0.0598-in. or 1.6-mm) 0.053 in. (1.34 mm) steel in accordance with Specification ~~A366/A366M~~A1008/A1008M.
 - 4.1.4.2 *Grade 2*—Substrate material is a particle or mineral board core with a minimum density of 45 lb/ft³ (722 kg/m³).

5. Ordering Information

- 5.1 Tops are included as part of the orders for items of furniture requiring tops. These orders shall include the following information:
 - 5.1.1 Type.
 - 5.1.2 Color or pattern of top covering material, or both.
 - 5.1.3 If Type III top is ordered, whether lee rail is required.

6. Materials and Manufacture

- 6.1 For typical design, see Fig. 1 and Fig. 2.
- 6.2 *Sheet Metal*, shall be cold-rolled steel, commercial quality, furniture grade in accordance with Specification ~~A366/~~A366MA1008/A1008M.

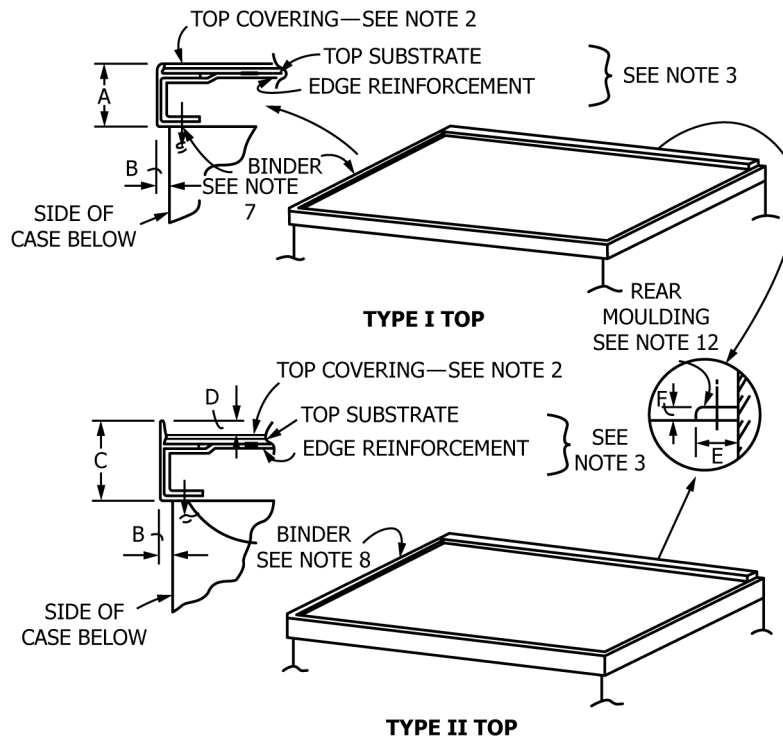

NOTE 1—For dimensions, see Table 1.

NOTE 2—Top covering for all type tops shall be high-pressure melamine laminate in accordance with ANSI/NEMA LD-3, with a maximum thickness of $\frac{1}{16}$ in. (1.59 mm), $\frac{1}{4}$ in. (6.35 mm), securely bonded to upper surface of substrate material.

NOTE 3—Material of substrate and edge reinforcements for Type I, II, and IV Grade 1 tops shall be a minimum of #6 USSG (1.52 mm or 0.0598 in.) 0.053 in. (1.34 mm) steel in accordance with Specification A366/A366MA1008/A1008M.

NOTE 4—Material of substrate for Type III tops shall be mineral board or particle board in accordance with ANSI A208.1 with a maximum thickness of 25.4 mm (1 in.).

NOTE 5—Material of substrate for Type IV Grade 2 tops shall be $\frac{1}{2}$ in. (13 mm) thick particle board in accordance with ANSI A208.1 or $\frac{1}{2}$ in. (13 mm) thick mineral board.

NOTE 6—For Type I, II, and IV Grade 1 tops, a stiffener shall be applied to any area of the steel substrate having an unsupported width greater than 89 mm (greater than $3\frac{1}{2}$ in.), in. (89 mm), see Fig. 3. Stiffener shall be #8 USSG (1.21 mm or 0.0478 in.) 0.042 in. (1.06 mm) in accordance with Specification A366/A366MA1008/A1008M.

NOTE 7—Edge binder for Type I top shall be of Type 6063-T1 anodized aluminum extrusion in accordance with Specification B221 and installed flush with upper surface of finished top.

NOTE 8—The combination edge binder and lee rail for Type II top shall be of Type 6063-T1 anodized aluminum extrusion in accordance with Specification B221 and installed so it projects above the upper surface of top a maximum of $\frac{3}{8}$ in. (9.53 mm) to act as a lee rail.

NOTE 9—For Type III tops, a self edge of the same material as the melamine top covering shall be securely bound to the top edge. See 6.8.2 for other details.

NOTE 10—For Type III top, a lee rail of polished and lacquered brass in accordance with Specification B16/B16M shall be applied to upper surface of finished top after application of melamine covering and shall project above the upper surface of the top a maximum of $\frac{1}{4}$ in. (1.35 mm), $\frac{1}{4}$ in. (6.35 mm).

NOTE 11—Type IV top is an inserted panel, and the edge binder is an integral part of the supporting furniture unit.

NOTE 12—The rear moulding for tops of Type I, II, and IV Grades 1 and 2 shall be an anodized aluminum extruded bar in accordance with Specification B221 attached to top with No. 6 oval head stainless steel machine screws.

NOTE 13—The rear moulding for Type III top shall be of polished and lacquered brass in accordance with Specification B16/B16M attached to top with No. 6 oval head brass machine screws.

NOTE 14—Type III and Type IV Grade 2 tops shall have a backing sheet securely bonded to underside of particle board substrate. Backing sheet shall be a resinous similar to top covering.

NOTE 15—Type IV Grade 1 and 2 tops shall be retained in case with No. 8 hex head jack screws and lock nuts spaced 203.2 mm (8 in.) 8 in. (203.2 mm) on centers.

NOTE 16—Completed top shall be securely attached to the supporting furniture unit below.

FIG. 1 Furniture Tops Types I and II

6.3 Joining:

6.3.1 Metal components shall be joined by welding or gluing with a structural adhesive as defined in Terminology D907.

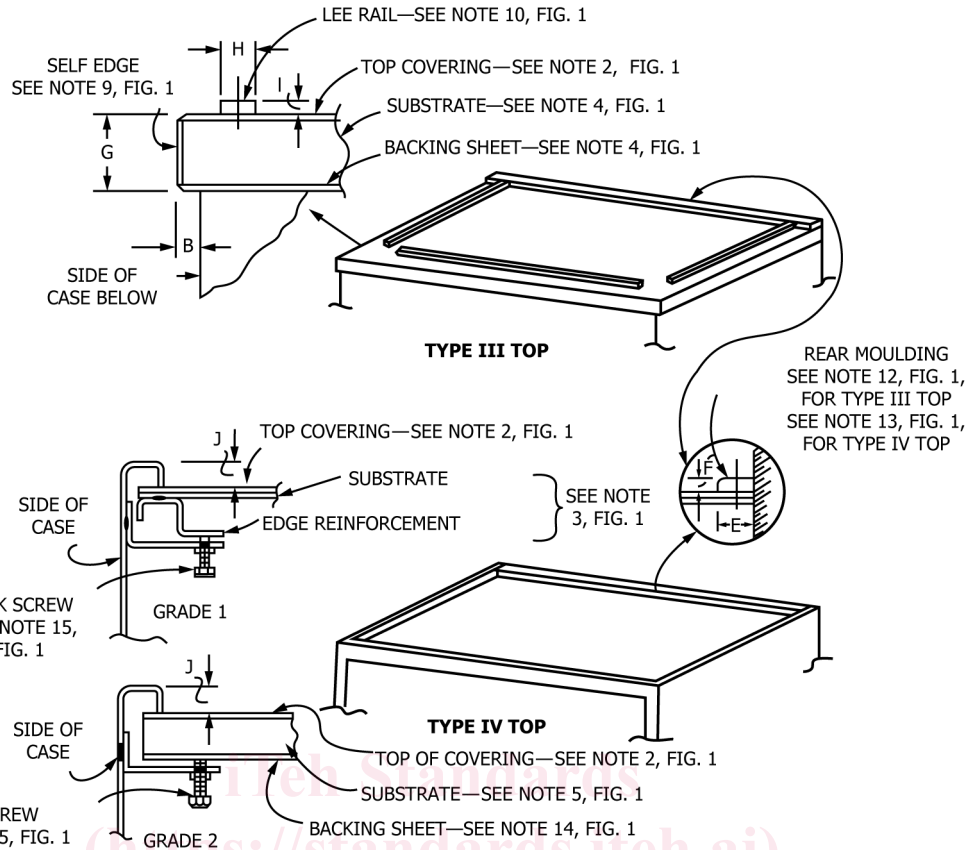

NOTE 1—For dimensions, see Table 2.

NOTE 2—See Notes 2 through 16 under Fig. 1.

FIG. 2 Furniture Tops Types III and IV

TABLE 1 Type I and II Top Dimensions

Designation	Dimension		Tolerances, + or -		
	in.	mm.	in.	mm.	
Edge binder height	A	1¼ max	32 max	1/16	2
Top overhang (side)	B	¼ max	6 max	1/16	2
Edge binder height	C	1⅝	35	1/16	2
Lee rail height	D	1/8	3	+¼ - 0	+6 - 0
Back molding width	E	5/8	16	1/16	2
Back molding height	F	3/16	5	1/32	1.0

TABLE 2 Type III and Type IV Top Dimensions

Designation	Dimension		Tolerances + or -		
	in.	mm.	in.	mm.	
Top overhang (side)	B	¼ max	6 max	1/16	2
Back molding width	E	5/8	16	1/16	2
Back molding height	F	3/16	5	1/32	1.0
Top thickness	G	1⅝ max	29 max	1/16	2
Lee rail width	H	5/16	8	1/32	1.0
Lee rail height	I	¼	6	1/32	1.0
Lee rail height	J	3/16	5	+1/16 - 0	+2 - 0

6.3.2 Joining shall be adequate to prevent racking during handling.

6.3.3 Spotwelds, shall be spaced approximately 3 in. (76 mm) on centers.

6.3.4 Visible Spotwelds, higher than the general surface of the metal, shall be ground flush.