



Designation: A48/A48M – 22

Standard Specification for Gray Iron Castings¹

This standard is issued under the fixed designation A48/A48M; the number immediately following the designation indicates the year of original adoption or, in the case of revision, the year of last revision. A number in parentheses indicates the year of last reapproval. A superscript epsilon (ϵ) indicates an editorial change since the last revision or reapproval.

*This standard has been approved for use by agencies of the U.S. Department of Defense.
This specification replaces Federal Specification QQ-I-652.*

1. Scope

1.1 This specification covers gray iron castings intended for general engineering use where tensile strength is a major consideration. Castings are classified on the basis of the tensile strength of the iron in separately cast test bars.

1.1.1 This specification subordinates chemical composition to tensile strength.

1.2 Castings produced to this specification are graded on the basis of minimum tensile strength obtained in special test coupons designed to standardize cooling rate. The tensile strength developed in certain casting sections may vary from test coupon values (see [X1.2](#)).

1.3 The values stated in either SI units or inch-pound units are to be regarded separately as standard. The values stated in each system may not be exact equivalents; therefore, each system shall be used independently of the other. Combining values from the two systems may result in nonconformance with the standard.

1.4 *This international standard was developed in accordance with internationally recognized principles on standardization established in the Decision on Principles for the Development of International Standards, Guides and Recommendations issued by the World Trade Organization Technical Barriers to Trade (TBT) Committee.*

2. Referenced Documents

- 2.1 *ASTM Standards:*²
[A644 Terminology Relating to Iron Castings](#)
[E8/E8M Test Methods for Tension Testing of Metallic Materials](#)

¹ This specification is under the jurisdiction of ASTM Committee A04 on Iron Castings and is the direct responsibility of Subcommittee A04.01 on Grey and White Iron Castings.

Current edition approved May 1, 2022. Published May 2022. Originally approved in 1905. Last previous edition approved in 2021 as A48/A48M – 03 (2021). DOI: 10.1520/A0048_A0048M-22.

² For referenced ASTM standards, visit the ASTM website, www.astm.org, or contact ASTM Customer Service at service@astm.org. For *Annual Book of ASTM Standards* volume information, refer to the standard's Document Summary page on the ASTM website.

2.2 *Military Standard:*³

[MIL-STD-129 Marking for Shipment and Storage](#)

2.3 *Federal Standard:*³

[Federal Standard No. 123 Marking for Shipment \(Civil Agencies\)](#)

3. Terminology

3.1 *Definitions:*

3.1.1 Definitions for many terms common to gray iron castings are found in Terminology [A644](#).

4. Classification

4.1 Castings ordered and produced in accordance with this specification are classified into a number of grades based on the properties of separately cast test bars ([Tables 1 and 2](#)). Each class is designated by a number followed by a letter. The number indicates the minimum tensile strength of the separately cast test bar, and the letter indicates the size of the test bar. Examples of proper designations are as follows:

4.1.1 Gray Iron Castings, ASTM Specification A48, Class 30B.

4.1.2 Gray Iron Castings, ASTM Specification A48, Class 40C.

5. Ordering Information

5.1 Orders for material to this specification shall include the following information:

5.1.1 ASTM designation number and year of issue,

5.1.2 Class of iron required (see [4.1](#) and [Tables 1 and 2](#)),

5.1.3 The size of the separately cast test bar (letter classification—A, B, C, or S) that best represents the thickness of the controlling section of the casting (see [Table 3](#)),

5.1.4 The tension test specimen (B or C) to be machined from test bar C (see [13.3](#), [Table 4](#), and [Fig. 1](#)),

5.1.5 The tension test specimen to be machined from test bar S (see [13.4](#), [Table 4](#), and [Fig. 1](#)),

5.1.6 Lot size (see [Section 10](#)),

5.1.7 Special requirements (see [Section 6](#)),

³ Available from Standardization Documents Order Desk, DODSSP, Bldg. 4, Section D, 700 Robbins Ave., Philadelphia, PA 19111-5098, <http://www.dodssp.daps.mil>.

TABLE 1 Requirements for Tensile Strength of Gray Cast Irons in Separately Cast Test Bars (Inch-Pound)

Class	Tensile Strength, min, ksi	Nominal Test Bar Diameter, in.
No. 20 A	20	0.8
No. 20 B		1.2
No. 20 C		2.0
No. 20 S		Bars S ^A
No. 25 A	25	0.88
No. 25 B		1.2
No. 25 C		2.0
No. 25 S		Bars S ^A
No. 30 A	30	0.88
No. 30 B		1.2
No. 30 C		2.0
No. 30 S		Bars S ^A
No. 35 A	35	0.88
No. 35 B		1.2
No. 35 C		2.0
No. 35 S		Bars S ^A
No. 40 A	40	0.88
No. 40 B		1.2
No. 40 C		2.0
No. 40 S		Bars S ^A
No. 45 A	45	0.88
No. 45 B		1.2
No. 45 C		2.0
No. 45 S		Bars S ^A
No. 50 A	50	0.88
No. 50 B		1.2
No. 50 C		2.0
No. 50 S		Bars S ^A
No. 55 A	55	0.88
No. 55 B		1.2
No. 55 C		2.0
No. 55 S		Bars S ^A
No. 60 A	60	0.88
No. 60 B		1.2
No. 60 C		2.0
No. 60 S		Bars S ^A

^A All dimensions of test bar S shall be as agreed upon between the manufacturer and the purchaser.

5.1.8 Saving tested specimens or unbroken test bars (see 15.1), and

5.1.9 Special preparation for delivery (see Section 19).

6. Special Requirements

6.1 When agreed upon in writing between the manufacturer and the purchaser, it may be necessary for the castings to meet special requirements as to hardness, chemical composition, microstructure, pressure tightness, radiographic soundness, dimensions, surface finish, and so forth.

7. Tensile Requirements

7.1 Test bars representing castings conforming to this specification shall meet the requirements for tensile strength as described in Tables 1 and 2.

TABLE 2 Requirements for Tensile Strength of Gray Cast Irons in Separately Cast Test Bars (Metric)

Class	Tensile Strength, min, MPa	Nominal Test Bar Diameter, mm
No. 150A	150	20 to 22
No. 150B		30
No. 150C		50
No. 150S		Bars S ^A
No. 175A	175	20 to 22
No. 175B		30
No. 175C		50
No. 175S		Bars S ^A
No. 200A	200	20 to 22
No. 200B		30
No. 200C		50
No. 200S		Bars S ^A
No. 225A	225	20 to 22
No. 225B		30
No. 225C		50
No. 225S		Bars S ^A
No. 250A	250	20 to 22
No. 250B		30
No. 250C		50
No. 250S		Bars S ^A
No. 275A	275	20 to 22
No. 275B		30
No. 275C		50
No. 275S		Bars S ^A
No. 300A	300	20 to 22
No. 300B		30
No. 300C		50
No. 300S		Bars S ^A
No. 325A	325	20 to 22
No. 325B		30
No. 325C		50
No. 325S		Bars S ^A
No. 350A	350	20 to 22
No. 350B		30
No. 350C		50
No. 350S		Bars S ^A
No. 375A	375	20 to 22
No. 375B		30
No. 375C		50
No. 375S		Bars S ^A
No. 400A	400	20 to 22
No. 400B		30
No. 400C		50
No. 400S		Bars S ^A

^A All dimensions of test bar S shall be as agreed upon between the manufacturer and the purchaser.

8. Dimensional Requirements

8.1 The castings shall conform to the dimensions or drawings furnished by the purchaser or, if there are no drawings, to the dimensions predicted by the pattern equipment supplied by the purchaser.

9. Workmanship and Finish

9.1 The surface of the casting shall be free of adhering sand, scale, cracks, and hot tears, as determined by visual examination.

TABLE 3 Separately Cast Test Bars for Use When a Specific Correlation Has Not Been Established Between the Test Bar and the Casting

Thickness of the Wall of the Controlling Section of the Casting, in. [mm]	Test Bar
Under 0.25 [under 5]	S
0.25 to 0.50 [5 to 14]	A
0.51 to 1.00 [15 to 25]	B
1.01 to 2 [26 to 50]	C
Over 2 [over 50]	S

9.2 No repairing by plugging or welding of any kind shall be permitted unless written permission is granted by the purchaser.

10. Sampling

10.1 A lot shall consist of one of the following:

10.1.1 All the metal poured from a single heating in a batch-type melting furnace.

10.1.2 All the metal from two or more batch-type melting furnaces poured into a single ladle or a single casting.

10.1.3 All the metal poured from a continuous melting furnace for a given period of time between changes in charge, processing conditions, or aim-for chemistry or 4 h, whichever is the shorter period.

10.1.3.1 The purchaser may agree to extend the 4-h time period to 8 h if the manufacturer can demonstrate sufficient process control to warrant such an extension.

11. Cast Test Bars

11.1 Test bars shall be separate castings poured from the same lot as the castings they represent and shall have dimensions as shown in Table 4. Allowance may be made for reasonable pattern draft within the tolerances shown in Table 4. Test bars A, B, and C are all standard test bars in the form of simple cylinders. Test bar S is special and is intended for use where the standard bars are not satisfactory.

11.2 The test bars shall be cast in dried, baked, or chemically bonded molds made mainly of an aggregate of siliceous sand with appropriate binders. The average grain size of the sand shall approximate that of the sand in which the castings are poured. Molds for the test bars shall be approximately at room temperature when poured. More than one test bar may be cast in a single mold, but each bar in the mold shall be surrounded by a thickness of sand which is not less than the diameter of the bar. A suitable design for a mold is shown in Fig. 2.

NOTE 1—The intent of these provisions is as follows: to prohibit the casting of test bars in molds of metal, graphite, zircon, light-weight aggregates, or other materials which would significantly affect the tensile strength of the iron; to prohibit control of tensile strength of the test bars by manipulation of the grain size of the sand; and to prohibit the casting of test bars in molds preheated substantially above room temperature.

11.3 Test bars that are intended to represent castings that are cooled in the mold to less than 900 °F [480 °C], before shakeout, shall be cooled in their molds to a temperature less than 900 °F [480 °C]. They then may be cooled in still air to room temperature.

11.4 Test bars that are intended to represent castings that are hotter than 900 °F [480 °C], when shaken out of their molds, shall be cooled as described in 11.3 or (by agreement between the manufacturer and the purchaser) may be shaken out of their molds at approximately the same temperature as the castings they represent.

11.5 When castings are stress-relieved, annealed, or otherwise heat-treated, test bars shall receive the same thermal treatment and shall be treated adjacent to the castings they represent.

12. Number of Tests and Retests

12.1 The tension test shall be conducted in accordance with Test Methods E8/E8M.

12.2 One tension test shall be performed on each lot and shall conform to the tensile requirements specified.

12.3 If the results of a valid test fail to conform to the requirements of this specification, two retests shall be made. If either retest fails to meet the specification requirements, the castings represented by these test specimens shall be rejected. A valid test is one wherein the specimen has been properly prepared and appears to be sound and on which the approved test procedure has been followed.

12.4 If sufficient separately cast test pieces are not available, the manufacturer shall have the option of removing a test specimen from a location of representative casting, as agreed upon between the manufacturer and purchaser.

12.5 If the first test results indicate that a heat treatment is needed to meet the test requirements, the entire lot of castings and the representative test specimens shall be heat treated together. Testing shall proceed in accordance with 12.1 – 12.3.

12.6 If, after testing, a test specimen shows evidence of a defect, the results of the test may be invalidated and another made on a specimen from the same lot.

13. Tension Test Specimens

13.1 For test bar A, the tension test specimen A, as shown in Fig. 1, shall be machined concentric with the axis of the test bar.

13.2 For test bar B, the tension test specimen B, as shown in Fig. 1, shall be machined concentric with the axis of the test bar.

13.3 For test bar C, tension test specimens B or C, as shown in Fig. 1, shall be machined concentric with the axis of the test bar. Unless the size of the tension test specimen to be machined from test bar C is specified in writing by the purchaser, the decision whether to use tension test specimen B or C shall be made by the manufacturer of the castings.

13.4 For test bar S, the nature and dimensions of the tension test specimen shall be determined by agreement between the manufacturer and purchaser.

14. Tension Test

14.1 Tension test specimens shall fit the holders of the testing machine in such a way that the load shall be axial.

TABLE 4 Diameters and Lengths of Cast Test Bars

Test Bar	As-Cast Diameter, in. [mm]			Length, in. [mm]	
	Nominal (Mid-Length)	Minimum (Bottom)	Maximum (Top)	Minimum (Specified)	Maximum (Recommended)
A	0.88 [22.4]	0.85 [21.6]	0.96 [24.4]	5.0 [125]	6.0 [150]
B	1.20 [30.5]	1.14 [29.0]	1.32 [33.5]	6.0 [150]	9.0 [230]
C	2.00 [50.8]	1.90 [48.3]	2.10 [53.3]	7.0 [175]	10.0 [255]
S ^A

^A All dimensions of test bar S shall be as agreed upon by the manufacturer and the purchaser.

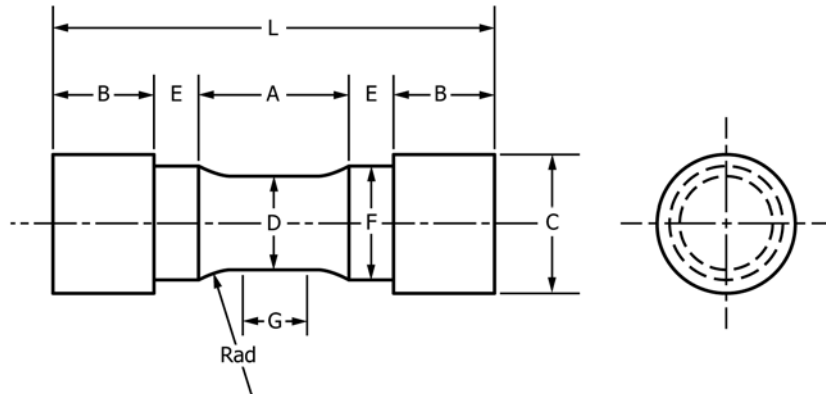

Dimensions, in. [mm]	Tension Test Specimen A	Tension Test Specimen B	Tension Test Specimen C
G—Length of parallel, min	0.50 [13]	0.75 [19]	1.25 [32]
D—Diameter	0.500 ± 0.010 [13 ± 0.25]	0.750 ± 0.015 [20 ± 0.4]	1.25 ± 0.025 [30 ± 0.6]
R—Radius of fillet, min	1 [25]	1 [25]	2 [50]
A—Length of reduced section, min	1¼ [32]	1½ [38]	2¼ [57]
L—Over-all length, min	3¾ [95]	4 [100]	6¾ [160]
C—Diameter of end section, approx	7/8 [20]	1¼ [20]	17/8 [47]
E—Length of shoulder, min	¼ [6]	¼ [6]	5/16 [8]
F—Diameter of shoulder	5/8 ± 1/64 [16 ± 0.4]	15/16 ± 1/64 [24 ± 0.4]	17/16 ± 1/64 [36 ± 0.4]
B—Length of end section	A	A	A

^A Optional to fit holders on testing machine. If threaded, root diameter shall not be less than dimension F. -8631bd101621/astm-a48-a48m-22

FIG. 1 Tension Test Specimens

14.2 The elapsed time from the beginning of loading in the tension test to the instant of fracture shall be not less than 15 s for test specimen A and not less than 20 s for specimens B and C.

15. Inspection

15.1 Unless otherwise specified in the contract or purchase order, the manufacturer shall be responsible for carrying out all the tests and inspections required by this specification, using his own or other reliable facilities, and he shall maintain complete records of all such tests and inspections. Such records shall be available for review by the purchaser.

15.1.1 When agreed upon between the manufacturer and purchaser, tested specimens or unbroken test bars from the same lot shall be saved for a period of three months after the date of the test report.

15.2 The purchaser reserves the right to perform any of the inspections set forth in the specification where such inspections are deemed necessary to ensure that supplies and services conform to the prescribed requirements.

16. Rejection and Resubmission

16.1 Any castings or lot of castings failing to comply with the requirements of this specification may, where possible, be reprocessed, retested, and reinspected. If the tests and inspections on the reprocessed casting(s) show compliance with this specification, the castings shall be acceptable; if they do not, they shall be rejected.

16.2 If the purchaser should find that a casting or lot of castings fails to comply with this specification subsequent to receipt at his facility, he shall so notify the manufacturer promptly and in no case later than six weeks after receipt of the shipment, stating clearly the basis for rejection.

17. Certification

17.1 When specified by the purchaser’s order or contract, a manufacturer’s certification or compliance statement that the casting or lot of castings was made, sampled, tested, and inspected in accordance with this specification, including a report of test results, shall be furnished at the time of shipment,