



Designation: ~~E2707--15~~ E2707 - 22

An American National Standard

Standard Test Method for Determining Fire Penetration of Exterior Wall Assemblies Using a Direct Flame Impingement Exposure¹

This standard is issued under the fixed designation E2707; the number immediately following the designation indicates the year of original adoption or, in the case of revision, the year of last revision. A number in parentheses indicates the year of last reapproval. A superscript epsilon (ϵ) indicates an editorial change since the last revision or reapproval.

1. ~~Scope~~ Scope*

1.1 This fire-test-response standard prescribes a method to assess the fire performance of a vertically oriented specimen exposed to direct flame impingement in a simulated external fire exposure potentially encountered in a 'Wildland Urban Interface' scenario. This test method provides data suitable for comparing the performance of materials, which are used as the exposed surfaces of exterior walls in construction applications.

NOTE 1—This test method closely follows the test procedure of California Office of State Marshal (SFM) Method 12-7A-1.²

1.2 This test method measures the ability of the wall system to resist fire penetration from the exterior into the wall cavity or unexposed side of the test assembly under the conditions of exposure.

1.3 This test method provides data suitable for comparing the performance of vertically oriented materials, products or assemblies in exterior construction applications. The test specimen shall be tested in thicknesses and configurations representative of actual end product or system uses.

1.4 Limitations of the test method are listed in Section 5.5.

1.5 The system of units to be used in referee decisions is the SI system of units; see **IEEE/ASTM SI-10** for further details. The units given in parentheses are for information only.

1.6 This standard is used to measure and describe the response of materials, products, or assemblies to heat and flame under controlled conditions, but does not by itself incorporate all factors required for fire hazard or fire risk assessment of the materials, products, or assemblies under actual fire conditions.

1.7 *This standard does not purport to address all of the safety concerns, if any, associated with its use. It is the responsibility of the user of this standard to establish appropriate safety, safety, health, and health environmental practices and determine the applicability of regulatory limitations prior to use.*

1.8 Fire testing is inherently hazardous. Adequate safeguards for personnel and property shall be employed in conducting these tests.

¹ This test method is under the jurisdiction of ASTM Committee E05 on Fire Standards and is the direct responsibility of Subcommittee E05.14 on External Fire Exposures. Current edition approved Oct. 1, 2015 April 1, 2022. Published November 2015 May 2022. Originally approved in 2009. Last previous edition approved in 2014 2015 as E2707-14-15. DOI: 10.1520/E2707-15.10.1520/E2707-22.

² 2007 2019 California Building Code, Chapter 7A [SFM], Materials and Construction Methods for Exterior Wildfire Exposure, Exterior Wall Siding and Sheathing, SFM Standard 12-7A-1.

*A Summary of Changes section appears at the end of this standard

1.9 *This international standard was developed in accordance with internationally recognized principles on standardization established in the Decision on Principles for the Development of International Standards, Guides and Recommendations issued by the World Trade Organization Technical Barriers to Trade (TBT) Committee.*

2. Referenced Documents

2.1 ASTM Standards:³

- D2898 Practice for Accelerated Weathering of Fire-Retardant-Treated Wood for Fire Testing
- D4442 Test Methods for Direct Moisture Content Measurement of Wood and Wood-Based Materials
- D4444 Test Method for Laboratory Standardization and Calibration of Hand-Held Moisture Meters
- D6662 Specification for Polyolefin-Based Plastic Lumber Decking Boards
- D7032 Specification for Establishing Performance Ratings for Wood-Plastic Composite and Plastic Lumber Deck Boards, Stair Treads, Guards, and Handrails
- E176 Terminology of Fire Standards
- E1354 Test Method for Heat and Visible Smoke Release Rates for Materials and Products Using an Oxygen Consumption Calorimeter
- E1474 Test Method for Determining the Heat Release Rate of Upholstered Furniture and Mattress Components or Composites Using a Bench Scale Oxygen Consumption Calorimeter
- E1740 Test Method for Determining the Heat Release Rate and Other Fire-Test-Response Characteristics of Wall Covering or Ceiling Covering Composites Using a Cone Calorimeter
- E2102 Test Method for Measurement of Mass Loss and Ignitability for Screening Purposes Using a Conical Radiant Heater
- E2257 Test Method for Room Fire Test of Wall and Ceiling Materials and Assemblies
- E2886 Test Method for Evaluating the Ability of Exterior Vents to Resist the Entry of Embers and Direct Flame Impingement
- IEEE/ASTM SI-10 American National Standard for Use of the International System of Units (SI): The Modern Metric System

2.2 ISO Standards:

- ISO 13943 Fire Safety—Vocabulary⁴

3. Terminology

3.1 *Definitions*—For definitions of terms used in this standard, see Terminology E176 and ISO 13943. In case of conflict, the definitions given in Terminology E176 shall prevail.

3.2 *Definitions of Terms Specific to This Standard:*

3.2.1 *orientation, n*—the vertical plane in which the exposed face of the test specimen is located during testing.

3.2.2 *siding (cladding), n*—any material that constitutes the exposed exterior covering of an exterior wall and such material is applied over sheathing or directly attached to the wall system.

3.2.3 *sheathing, n*—the material placed on an exterior wall beneath cladding or siding and directly attached to the wall system used over the wall framework and is attached directly to the wall framing members. Materials called sheathing that are not placed beneath cladding or siding shall be classified as cladding or siding.

3.2.4 *sustained flaming, n*—flame on or over the surface of a test specimen that lasts longer than a period of 4 s.

4. Summary of Test Method

4.1 This test method provides for the direct flame exposure of a wall specimen to a flame source centered at the base of a 1220 mm by 2440 mm (4 ft by 8 ft) test assembly.

4.2 This test method employs a gas burner to produce a diffusion flame in contact with the test wall assembly.

4.3 The gas burner produces a prescribed net rate of heat output of 150 kW (8535 BTU/min) for a period of 10 min, after which the flame exposure is terminated.

³ For referenced ASTM standards, visit the ASTM website, www.astm.org, or contact ASTM Customer Service at service@astm.org. For *Annual Book of ASTM Standards* volume information, refer to the standard's Document Summary page on the ASTM website.

⁴ Available from International Organization for Standardization (ISO), 1, ch. de la Voie-Creuse, Case postale 56, CH-1211, Geneva 20, Switzerland, <http://www.iso.ch>.

4.4 The test method measures the ability of the wall system to resist fire penetration from the exterior to the unexposed side of the test assembly under the conditions of exposure. Observations are made for the appearance of sustained flaming or glow on the unexposed side or sustained glowing on the unexposed side, or both, at the end of a 60 min observation period.

5. Significance and Use

5.1 The test method described herein measures the ability of the exterior wall covering material or system to resist fire penetration from the exterior to the unexposed side of the wall assembly under the specified conditions of exposure.

5.2 Representative joints and other characteristics of an assembly shall be included in a test specimen when these details are representative of the construction of the end-use product(s).

5.3 This test method is applicable to end-use product(s) not having an ideally planar external surface.

5.4 The overall performance of the test specimen is visually documented by full-color photographic records. Video ~~taping~~ recording of the complete fire test is an acceptable alternative to the photographic record. ~~The use of infrared~~ Infrared photography of the unexposed side of the test wall can be used to ~~reveal development~~ identify areas of increasing temperatures or persisting hot spots.

5.5 In this procedure, the specimens are subjected to a specific set of laboratory fire test exposure conditions. If different test conditions are substituted or the anticipated end-use conditions are changed, it is not known whether it is possible by use of this test to predict changes in the performance characteristics measured. Therefore, the results are strictly valid only for the fire test exposure conditions described in this procedure.

6. Safety Precautions

6.1 The test procedures involve high temperatures and combustion processes. Therefore, the potential exists for burns, ignition of extraneous objects or clothing, and for inhalation of combustion products.

7. Apparatus

7.1 Unless otherwise noted, dimensions in the following descriptions, shall be followed with a tolerance of ± 13 mm (0.5 in.).

7.2 *Wall Assembly Holding Fixture*—The test specimen support assembly shown in Fig. 1 is designed to permit rapid installation and removal of wall assemblies, and to prevent edge penetration of fire at the margins of the wall assembly. It includes a sturdy frame assembly to hold the specimen and a simulated soffit that is non-combustible. The frame assembly permits a 1220 mm by 2440 mm (4 ft by 8 ft) prefabricated wall section to be inserted from the rear and to seal in such a way that protects the edges from fire. Side shields are situated near the vertical edges and to within 304 mm (12 in.) of the top of the test wall assembly as shown in Fig. 1 to aid in minimizing extraneous drafts to the surface of the assembly.

7.3 *Burner Details*—The ignition source for the test shall be a gas diffusion burner with a nominal 100 mm wide by 1000 mm long (4 in. wide by 39 in. long) porous top surface of a refractory material, as shown in Fig. 2. With the exception of top surface dimensions, the essential configuration of the burner is comparable to the burner design described in Test Method E2257.

7.4 The burner enclosure shall be positioned so that it is centered relative to the width of the test wall. The distance from the bottom of the test specimen to the top surface of the burner shall be 300 mm \pm 50 mm (12 in. \pm 2 in.). The bottom of the test specimen shall be protected from burner fire exposure by the placement of a 1220 mm (4 ft) wide thermal barrier consisting of nominal 19 mm (0.75 in.) cement board (or equivalent) between the burner enclosure and the test specimen. The burner enclosure shall be in contact with the protective barrier. The thermal barrier shall be positioned so that the top edge extends 76 mm \pm 25 mm (3 in. \pm 1 in.) above the top edge of the burner, and fastened to the base of the wall in such a manner to prevent obstruction of the burner flame caused by distortion away from the surface of the wall. Any gaps between the top edge of the thermal barrier and the test wall surface shall be filled with ceramic wool, or equivalent, prior to the test.

7.5 Natural gas, methane or propane shall be supplied to the burner through a metered control system. The gas supply to the burner shall produce a net heat output of 150 kW \pm 8 kW (8535 Btu/min \pm 454 Btu/min) throughout the flame exposure.

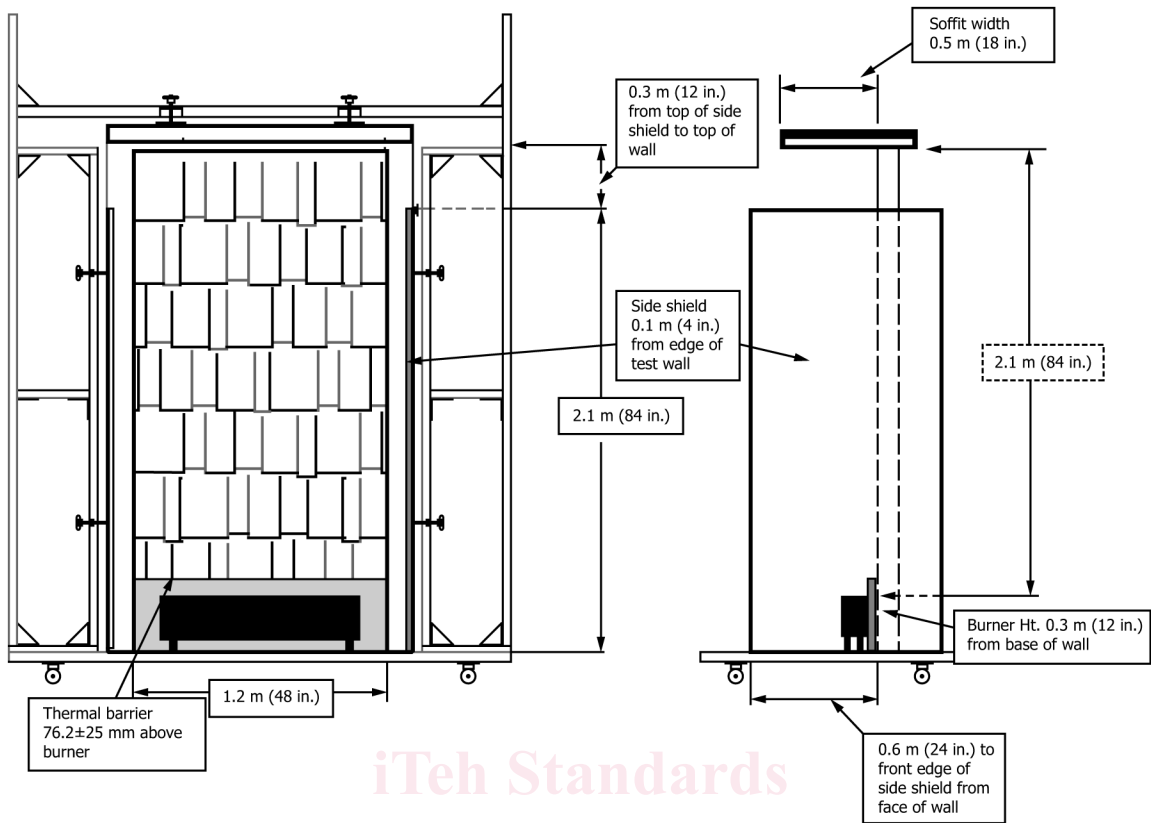

FIG. 1 Test Fixture

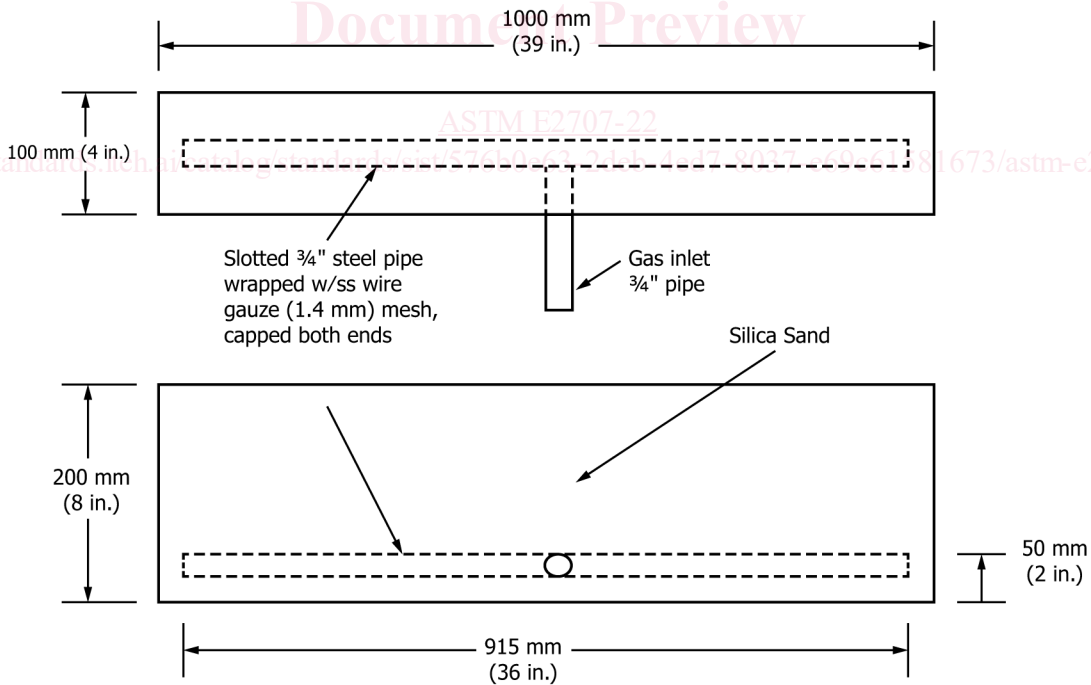

FIG. 2 Gas Burner Ignition Source

7.6 The burner shall be ignited by a pilot burner or a remotely controlled spark igniter.

7.7 *Moisture Meter*—Moisture meters used to determine the moisture content of wood products for compliance with 8.8.4.2 shall be calibrated as described in Test Method D4444.

8. Test Specimen

8.1 Test specimen's dimensions shall be 1220 mm (4 ft) wide by 2440 mm (8 ft) high. The test specimen shall be representative of the end-use wall assembly except as specified in 8.3 and 8.4. The test specimen shall be mounted in the steel frame holding fixture assembly as shown in Fig. 1.

8.2 The test specimen shall incorporate joint detail(s) representative of actual installation.

8.3 For wall assemblies without internal cavity spaces, the entire wall assembly shall constitute the test specimen to be tested. The wall assembly shall be constructed in accordance with manufacturer's specifications or building code requirements, or both, where applicable. Other components of the wall assembly, such as building felt and sheathing, are employed to conform to the manufacturer's specifications or building codes, or both.

8.4 For wall assemblies with internal cavity spaces, the materials on what would be considered the interior (unexposed) side of the wall assembly shall be omitted from the test specimen. Materials such as insulation normally installed within the cavity space shall be omitted from the test specimen. The wall assembly used as the test specimen shall include the structural support elements and any sheathing, weather barrier and cladding attached to the exterior surface of the structural support elements.

8.5 For wall assemblies composed of layered materials, such as sheathing, siding (cladding) and underlayment, the installation of such layered materials shall be in accordance with manufacturer's instructions, or in the absence of such instructions, applicable building code requirements. In the absence of manufacturer's specifications, the wall assembly shall include the following minimum components: nominal 2 by 4 studs spaced 410 mm (16 in.) on center, and the desired exterior siding material. If sheathing is used, tests shall be run on typical $7\frac{1}{16}$ in. oriented strandboard (OSB) of Exposure 1 rating. Where specified by the manufacturer, sheathing material and installation shall be in accordance with the manufacturer's instructions. The sheathing shall have one vertical seam on a selected stud with a 3 mm (0.125 in.) gap. The type, thickness, and installation method of any sheathing shall be included in the report.

8.6 Protect the vertical and horizontal edges of the test specimen with ~~12-mm~~ 12 mm ceramic wool blanket (or equivalent) to eliminate the gap between the holder and the test specimen and prevent unwanted edge effects caused by heat transfer to the edges of the test specimen through the sample holder.

8.7 *Replicates*—Three matched test specimen assemblies shall be tested.

8.8 *Accelerated Aging/Weathering and Pre-test Conditioning of Test Material:*

8.8.1 When it is anticipated that a regulatory or other agency will require pre-test accelerated aging/weathering of the samples, the manufacturer shall have the option to conduct such weathering. Weathering shall be conducted as specified by the regulatory agency or applicable methods as specified for the product. The process shall evaluate the potential for the fire test response characteristics as measured in this test method to deteriorate due to accelerated aging/weathering of the wall material. Details of the weathering method used, or reference to a standard test method, shall be included in the report (see Appendix X2).

8.8.2 Pieces of any hygroscopic materials from the same stock from which the test assembly was constructed shall be tacked to the assembly during construction in such a manner that they are easily removed. These pieces shall be conditioned with the completed assemblies.

8.8.3 The completed test assemblies are to be stored indoors at temperatures not lower than ~~16°C (60°F)~~ 16 °C (60 °F) nor higher than ~~32°C (90°F)~~ 32 °C (90 °F) for the period of time necessary to cure the assembly components. Test assemblies are to be stored so that each will be surrounded by freely circulating air.

8.8.4 Just before the test assembly is tested, the pieces of hygroscopic materials prepared in 8.8.2 shall be tested for moisture content.

8.8.4.1 Make the moisture determination on two samples from each piece and report the average. For lumber and other wood-based materials, use Test Methods **D4442**. Alternatively, the moisture content for lumber and other wood-based materials is permitted to be measured using a moisture meter complying with **7.7**. For other hygroscopic materials, use test methods appropriate for those materials.

8.8.4.2 For lumber used in the construction of the supporting wall structure, the moisture content shall not be more than 12 %. For wood sheathing, the moisture content shall not exceed 8 %. For other hygroscopic materials, the moisture shall be within ranges specified by the manufacturer before the assembly is constructed. These specified ranges shall be typical for exposure at $77\text{ }^{\circ}\text{F} \pm 9^{\circ}\text{F}$ ($25\text{ }^{\circ}\text{C} \pm 5^{\circ}\text{C}$) and $55 \pm 10\%$ relative humidity.

9. Calibration

9.1 Burner Calibration:

9.1.1 The gas supply to the burner shall be the same as used for testing. The gas shall be metered and kept constant throughout the calibration test.

9.1.2 Place the gas burner in the configuration to be used for testing and obtain a heat release rate value of 150 kW.

9.1.3 Take measurements at least once every 6 s and start 1 min prior to ignition of the burner. Determine the average heat output over a period of at least 1 min by the oxygen consumption method, or calculate the heat output from the gas mass flow and the net heat of combustion.

9.1.4 Perform calibration prior to each day of testing.

10. Procedure

10.1 The ambient temperature in the test room shall be above 15°C (60°F) 15°C (60°F) and the relative humidity shall be less than 75 %. The test room shall be draft-protected and equipped with an exhaust hood system for removal of products of combustion during testing.

10.2 The horizontal air flow, measured at a horizontal distance of 0.5m (20 in.) from the edge of the wall assembly, shall not exceed 0.5 m/s (1.64 ft/s).

10.3 Prior to testing, and without the test specimen in place, position the frame assembly under the exhaust hood and set the gas burner for the prescribed level of output.

10.4 Once the burner output is verified, position the specimen holder assembly at the desired test location under the collection hood.

10.4.1 Insert the test specimen into the frame assembly, sealing all edges with ceramic wool.

10.4.2 Simultaneously ignite the gas burner and start the timer marking the beginning of the test. Control the burner to a constant 150 ± 8 kW output. Control the hood duct flow to collect all products of combustion.

10.4.3 Continue the flame exposure for a period of 10 min, then shut off the burner. If sustained flaming lasting longer than 4 s on the unexposed side of the test assembly has not occurred, continue the test for an additional 60 min, observing for evidence of sustained flaming lasting longer than 4 s or glow on the unexposed side. Terminate the test prior to the completion of the 60 min observation period at such time as all evidence of flame, glow and smoke has disappeared.

NOTE 2—An infrared thermometer has been found to be useful to detect the increase of temperature on the unexposed side of the test assembly.

10.4.4 Perform photographic or video documentation, or both, before, during and after each test.

10.4.5 Perform the tests in triplicate and report as specified in Section **11**.

11. Report

11.1 The report shall include the following:

11.1.1 Name and address of the testing laboratory,

11.1.2 Name and address of test sponsor,

11.1.3 Description of the test specimen assembly including construction details of the wall system, including details of individual components and the manufacturer's installation details and limitations as applicable.

11.1.4 Number of specimens tested,

11.1.5 Conditioning of test specimen assemblies,

11.1.6 Pre-test accelerated aging/weathering exposure, as applicable,

11.1.7 Moisture content of hygroscopic elements of wall system construction at the time of testing,

11.1.8 Details of the calibration including heat supply rate,

11.1.9 Date of test and identification number and date of report,

11.2 *Test Results*—The test results shall include:

11.2.1 A notation of the time and location of sustained flaming on the unexposed side of the test assembly during the test along with the sequence number of the test specimen.

11.2.2 A determination of the presence of glow on the unexposed side of the assembly at the end of the 60 min observation period.

11.2.3 Observations of the burning characteristics of the exposed surface of the test wall during and after the test exposure.

12. Precision and Bias

12.1 Repeatability and bias data is currently being worked on by task group E5.14.01.

13. Keywords

13.1 exterior wall covering; fire resistance; fire-test-response characteristic; siding; wall assembly

APPENDIXES

(Nonmandatory Information)

X1. COMMENTARY

X1.1 Introduction:

X1.1.1 This test method was developed in response to recommendations developed by the California Office of the State Fire Marshal (SFM) and the International Wildland-Urban Interface Code (IWUIC) regarding the enhancement of exterior fire protection of structures in a wildland fire (exterior wildfire exposure). The SFM recommendations established performance criteria for a variety of materials to be used on the exterior buildings, structures, and detached accessory structures. This test method is intended to address one component of an exterior wildfire exposure, that is, exterior walls exposed to direct flame impingement. The purpose of this standard is to provide a definitive set of procedures for the evaluation and measurement of the resistance to