



Designation: ~~D5448/D5448M—16~~ D5448/D5448M – 22

Standard Test Method for Inplane Shear Properties of Hoop Wound Polymer Matrix Composite Cylinders¹

This standard is issued under the fixed designation D5448/D5448M; the number immediately following the designation indicates the year of original adoption or, in the case of revision, the year of last revision. A number in parentheses indicates the year of last reapproval. A superscript epsilon (ϵ) indicates an editorial change since the last revision or reapproval.

This standard has been approved for use by agencies of the U.S. Department of Defense.

1. Scope

1.1 This test method determines the inplane shear properties of wound polymer matrix composites reinforced by high-modulus continuous fibers. It describes testing of hoop wound (90°) cylinders in torsion for determination of inplane shear properties.

1.2 The technical content of this ~~standard-test method~~ has been stable since 1993 without significant objection from its stakeholders. As there is limited technical support for the maintenance of this ~~standard-test method~~, changes since that date have been limited to items required to retain consistency with other ASTM D30 Committee standards, including editorial changes and incorporation of updated guidance on specimen preconditioning and environmental testing. The ~~standard-test method~~, therefore, should not be considered to include any significant changes in approach and practice since 1993. Future maintenance of the ~~standard-test method~~ will only be in response to specific requests and performed only as technical support allows.

1.3 Units—The values stated in either SI units or inch-pound units are to be regarded separately as standard. The values stated in each system ~~may~~ are not ~~be~~necessarily exact equivalents; therefore, to ensure conformance with the standard, each system shall be used independently of the other. ~~Combining~~ other, and values from the two systems ~~may result in non-conformance with the standard~~ shall not be combined.

1.3.1 Within the text, the inch-pound units are shown in brackets.

1.4 *This standard does not purport to address all of the safety concerns, if any, associated with its use. It is the responsibility of the user of this standard to establish appropriate ~~safety~~ safety, health, and ~~health~~ environmental practices and determine the applicability of regulatory limitations prior to use.*

1.5 *This international standard was developed in accordance with internationally recognized principles on standardization established in the Decision on Principles for the Development of International Standards, Guides and Recommendations issued by the World Trade Organization Technical Barriers to Trade (TBT) Committee.*

2. Referenced Documents

2.1 ASTM Standards:²

D792 Test Methods for Density and Specific Gravity (Relative Density) of Plastics by Displacement

D883 Terminology Relating to Plastics

¹ This test method is under the jurisdiction of ASTM Committee D30 on Composite Materials and is the direct responsibility of Subcommittee D30.04 on Lamina and Laminate Test Methods.

Current edition approved July 1, 2016 May 1, 2022. Published July 2016 May 2022. Originally approved in 1993. Last previous edition approved in 2014 2016 as D5448/D5448M—14 D5448/D5448M – 16. DOI: 10.1520/D5448_D5448M-16.10.1520/D5448_D5448M-22.

² For referenced ASTM standards, visit the ASTM website, www.astm.org, or contact ASTM Customer Service at service@astm.org. For *Annual Book of ASTM Standards* volume information, refer to the standard's Document Summary page on the ASTM website.



D2584 Test Method for Ignition Loss of Cured Reinforced Resins
 D2734 Test Methods for Void Content of Reinforced Plastics
 D3171 Test Methods for Constituent Content of Composite Materials
 D3878 Terminology for Composite Materials
 D5229/D5229M Test Method for Moisture Absorption Properties and Equilibrium Conditioning of Polymer Matrix Composite Materials
 D5449/D5449M Test Method for Transverse Compressive Properties of Hoop Wound Polymer Matrix Composite Cylinders
 D5450/D5450M Test Method for Transverse Tensile Properties of Hoop Wound Polymer Matrix Composite Cylinders
 E6 Terminology Relating to Methods of Mechanical Testing
 E111 Test Method for Young's Modulus, Tangent Modulus, and Chord Modulus
 E122 Practice for Calculating Sample Size to Estimate, With Specified Precision, the Average for a Characteristic of a Lot or Process
 E177 Practice for Use of the Terms Precision and Bias in ASTM Test Methods
 E251 Test Methods for Performance Characteristics of Metallic Bonded Resistance Strain Gages
 E456 Terminology Relating to Quality and Statistics
 E691 Practice for Conducting an Interlaboratory Study to Determine the Precision of a Test Method
 E1237 Guide for Installing Bonded Resistance Strain Gages

3. Terminology

3.1 *Definitions*—Terminology D3878 defines terms relating to high-modulus fibers and their composites. Terminology D883 defines terms relating to plastics. Terminology E6 defines terms relating to mechanical testing. Terminology E456 and Practice E177 define terms relating to statistics. In the event of a conflict between terms, Terminology D3878 shall have precedence over other standards.

NOTE 1—If the term represents a physical quantity, its analytical dimensions are stated immediately following the term (or letter symbol) in fundamental dimension form, using the following ASTM standard symbology for fundamental dimensions, shown within square brackets: $[M]$ for mass, $[L]$ for length, $[T]$ for time, $[\theta]$ for thermodynamic temperature, and $[nd]$ for non-dimensional quantities. Use of these symbols is restricted to analytical dimensions when used with square brackets, as the symbols may have other definitions when used without the brackets.

3.2 Description of Terms Specific to This Standard:³

3.2.1 *hoop wound, n*—a winding of a cylindrical component where the filaments are circumferentially oriented.

3.2.2 *inplane shear modulus, G_{12} [$ML^{-1}T^{-2}$], n*—the elastic shear modulus of a unidirectional material in the plane defined by axes parallel and perpendicular to the reinforcing fibers.

3.2.3 *inplane shear strain at failure, γ_{12}^u [nd], n*—the value of inplane shear strain at failure when an inplane shear force is applied to the material.

3.2.4 *inplane shear strength, τ_{12} [$ML^{-1}T^{-2}$], n*—the strength of a unidirectional material when an inplane shear force is applied to the material.

3.2.5 *specimen—specimen, n*—a single part cut from a winding that meets the specifications of Fig. 1. ~~Each~~; each winding may yield several specimens.

3.2.6 *winding—winding, n*—an entire part completed by one winding operation and then cured.

4. Summary of Test Method

4.1 A thin walled hoop wound cylinder nominally 100 mm [4 in.] in diameter and 140 mm [~~5½ in.~~ in.] in length is bonded into two end fixtures. The specimen/fixture assembly is mounted in the testing machine and monotonically loaded in inplane shear

³ If the term represents a physical quantity, its analytical dimensions are stated immediately following the term (or letter symbol) in fundamental dimension form, using the following ASTM standard symbology for fundamental dimensions, shown within square brackets: $[M]$ for mass, $[L]$ for length, $[T]$ for time, $[\theta]$ for thermodynamic temperature, and $[nd]$ for nondimensional quantities. Use of these symbols is restricted to analytical dimensions when used with square brackets, as the symbols may have other definitions when used without the brackets.

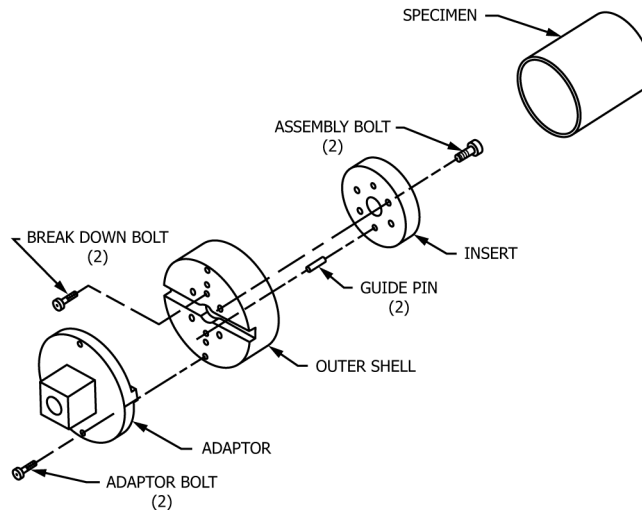

FIG. 1 Assembly Drawing for the Shear Fixture and Specimen

while recording force. The inplane shear strength can be determined from the maximum force carried prior to failure. If the cylinder strain is monitored with strain gauges, then the stress-strain response, the inplane shear strain at failure, and the inplane shear modulus can be derived.

5. Significance and Use

5.1 This test method is designed to produce inplane shear property data for material specifications, research and development, quality assurance, and structural design and analysis. Factors that influence the inplane shear response and should therefore be reported are material, method of material preparation, specimen preparation, specimen conditioning, environment of testing, specimen alignment and gripping, speed of testing, void content, and fiber volume fraction. Properties, in the test direction, that may be obtained from this test method are as follows:

5.1.1 *Inplane Shear Strength, τ_{12}^u ,*

5.1.2 *Inplane Shear Strain at Failure, γ_{12}^u ,* and

5.1.3 *Inplane Shear Modulus, G_{12} .*

6. Interferences

6.1 *Material and Specimen Preparation*—Poor material fabrication practices, lack of control of fiber alignment, and damage induced by improper specimen machining are known causes of high material data scatter in composites.

6.2 *Bonding Specimens to Test Fixtures*—A high percentage of failures in or near the bond between the test specimen and the test fixture, especially when combined with high material data scatter, is an indicator of specimen bonding problems. Specimen-to-fixture bonding is discussed in 11.5.

6.3 *System Alignment*—Excessive bending or axial loading will cause premature failure, as well as highly inaccurate shear modulus determination. Every effort should be made to eliminate excess bending and axial loading from the test system. Bending and axial loading may occur due to misaligned grips, misaligned specimens in the test fixtures, or from departures of the specimens from tolerance requirements. The alignment should always be checked as discussed in 13.2.

7. Apparatus

7.1 *Micrometer and Calipers*—A micrometer with a 4 to 7 mm [0.16 to 0.280, 32 in.] nominal diameter ball-interface or a flat anvil interface shall be used to measure the specimen wall thickness, inner diameter, and outer diameter. A ball interface is recommended for these measurements when at least one surface is irregular (e.g., (for example, a coarse peel ply surface, which is neither smooth nor flat). A micrometer or caliper with a flat anvil interface shall be used for measuring the overall

specimen length, the gauge length (the free length between the fixtures), and other machined surface dimensions. The use of alternative measurement devices is permitted if specified (or agreed to) by the test requestor and reported by the testing laboratory. The accuracy of the instruments shall be suitable for reading to within $\pm 1\%$ of the sample dimensions. For typical specimen geometries, an instrument with an accuracy of ± 0.0025 mm [± 0.0001 in.] is adequate for wall thickness measurements, while an instrument with an accuracy of ± 0.025 mm [± 0.001 in.] is adequate for measurement of the inner diameter, outer diameter, overall specimen length, gauge length, and other machined surface dimensions.

7.2 *Inplane Shear Fixture*—The inplane shear fixture consists of a steel outer shell, insert, and adaptor. An assembly drawing for these components and the test fixture is shown in Fig. 1.

7.2.1 *Outer Shell*—The outer shell (SI units, see Fig. 2; inch-pound units, see Fig. 3) is circular with a concentric circular hollow in one face, a groove along the diameter of the other face, and a center hole through the thickness. Along the diameter perpendicular to the groove, three pairs of small eccentric holes are placed at three radial distances. The two outer pairs of holes are threaded.

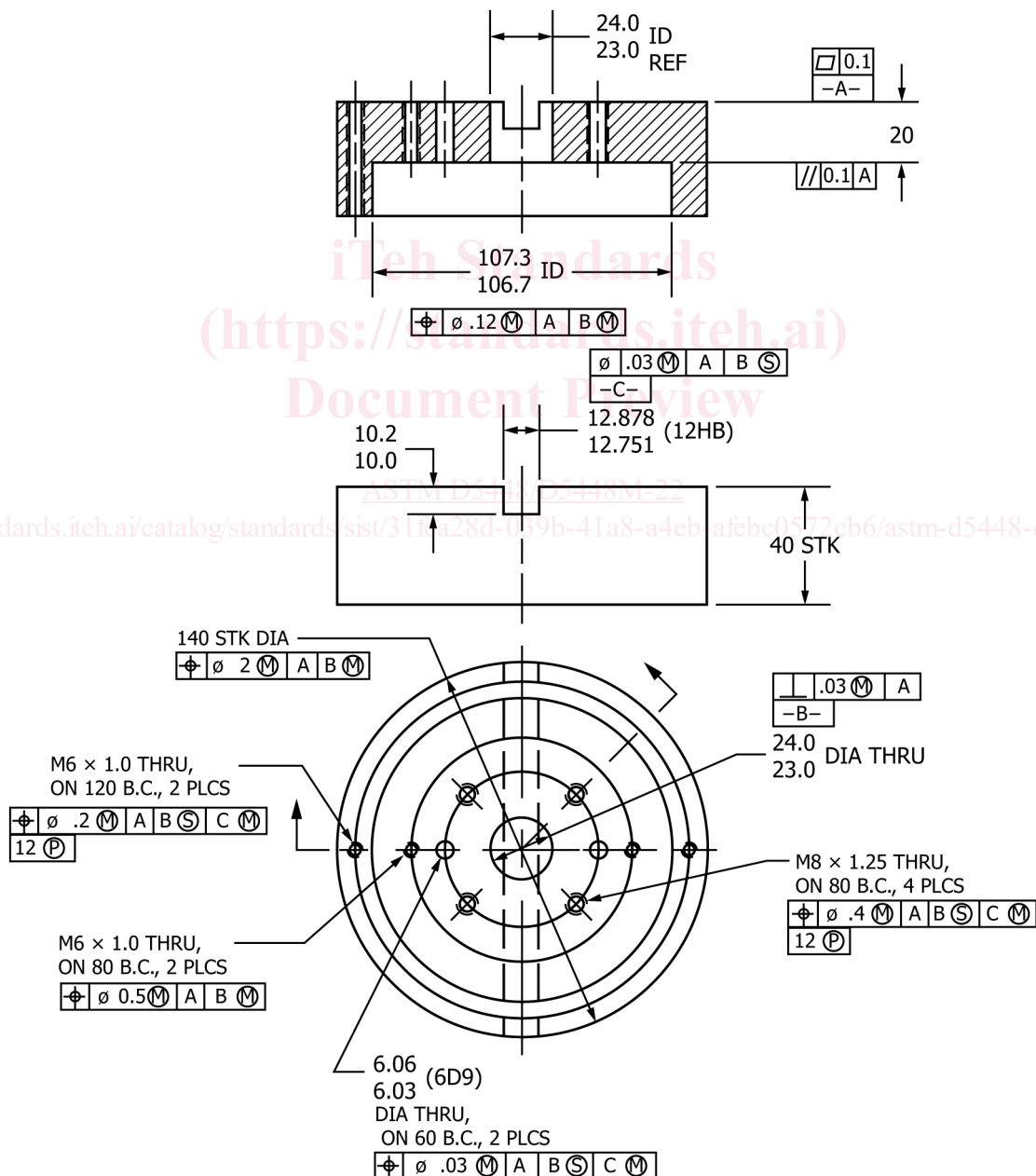

FIG. 2 Outer Shell of the Shear Fixture in SI Units

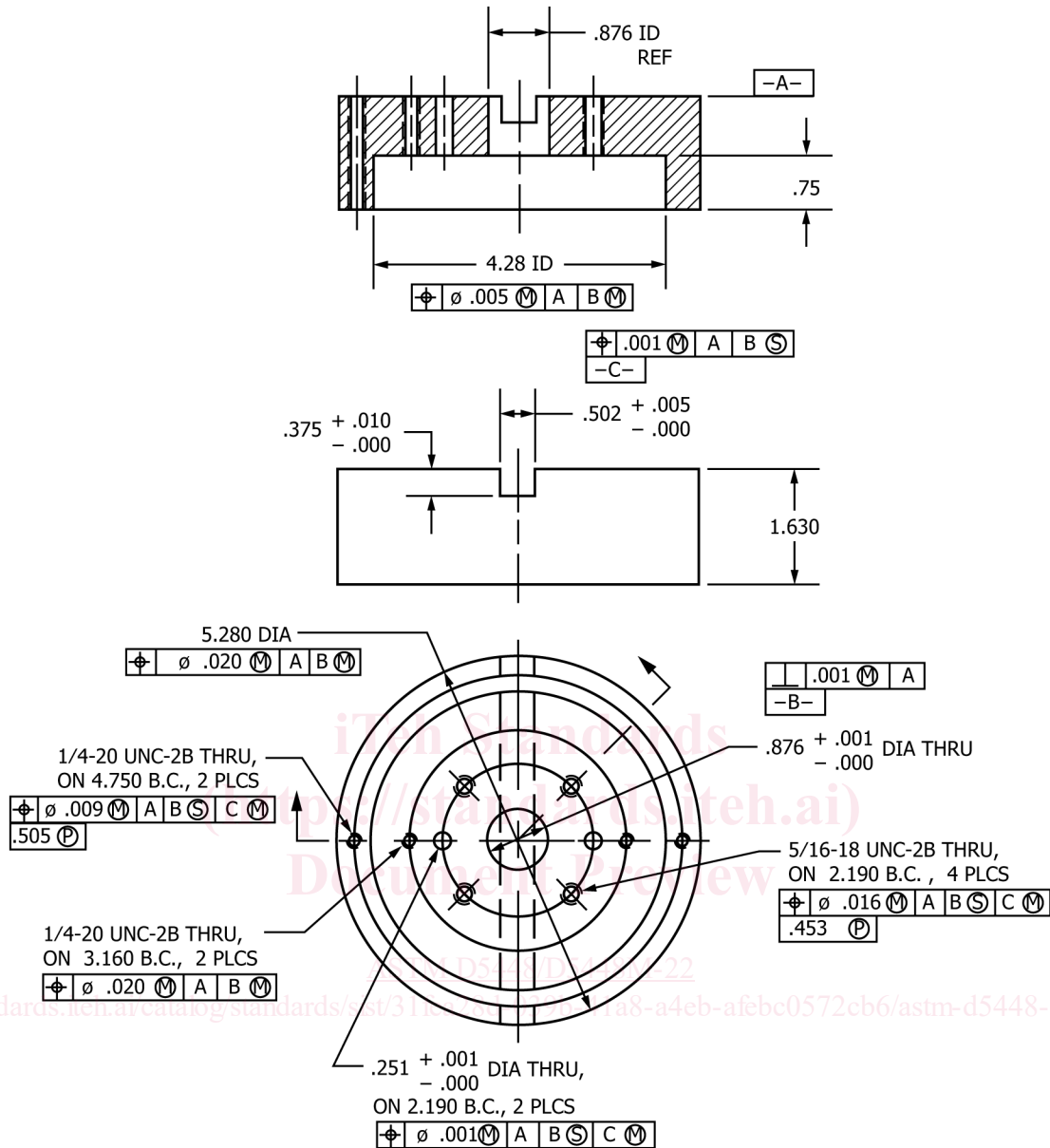

FIG. 3 Outer Shell for the Shear Fixture in Inch-Pound Units

Four additional threaded holes are placed at the same radial distance as the innermost pair of holes at 90° intervals starting 45° from the diameter that passes through the center groove.

7.2.2 *Insert*—The fixture insert is circular with a center hole through the thickness (SI units, see Fig. 4; inch-pound units, see Fig. 5). Two sets of holes are placed along a concentric centerline. These holes align with the innermost set of holes in the outer shell. The set of 4 holes at 90° intervals are counterbored. The insert is fastened inside the hollow of the outer shell to form the concentric groove used to put the specimen in the fixture.

7.2.3 *Adaptor*—The adaptor is circular with a square central torque nut raising out of one face, a flange along a diameter on the other face, and a central hole (SI units, see Fig. 6; inch-pound units, see Fig. 7). Two bolt holes are placed equidistant from the adaptor center on a diameter perpendicular to the centerline of the flange. The adaptor is fastened to the outer shell. The flange of the adaptor fits into the groove of the outer shell. The complete inplane shear specimen/fixture assembly is seen in Fig. 1.

NOTE 2—The outer shell and insert for the compression fixture are the same outer shell and insert used for the fixtures in Test Methods D5449/D5449M and D5450/D5450M.

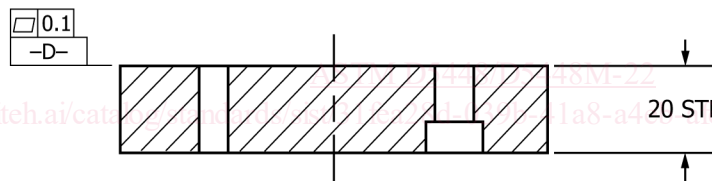
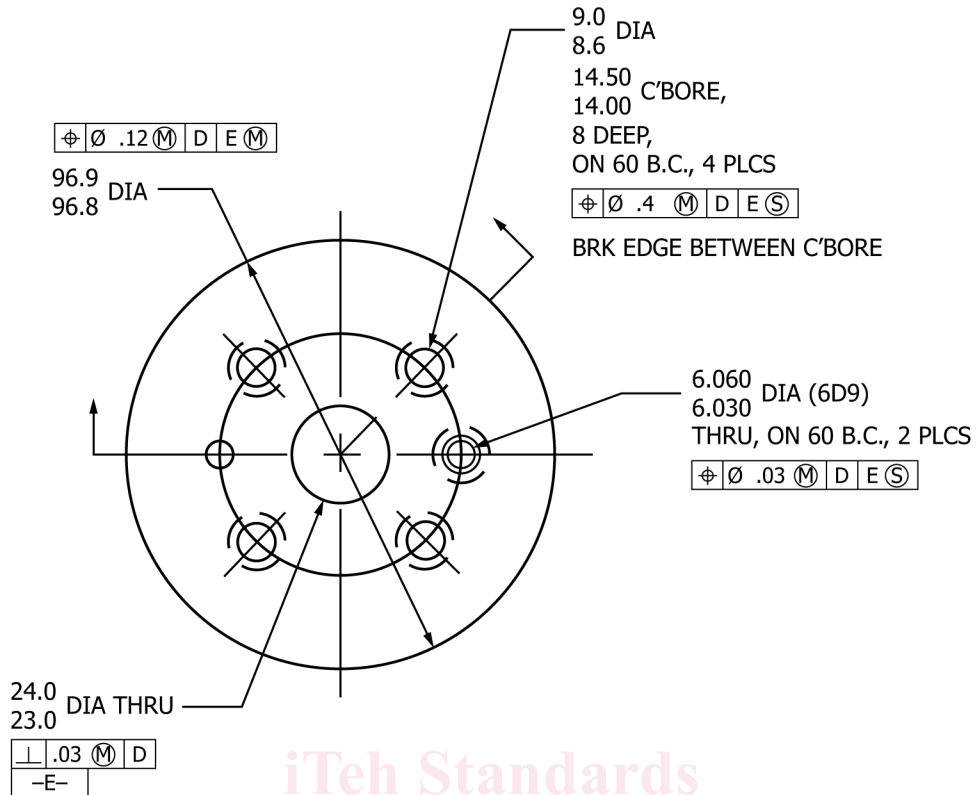

FIG. 4 Insert of the Shear Fixture in SI Units

7.3 Testing Machine, comprised of the following:

7.3.1 *Fixed Member*—A fixed or essentially stationary member, with respect to rotation, to which one end of the torsion specimen/fixture/adaptor assembly, shown in Fig. 1, can be attached.

7.3.2 *Rotational Member*—A rotational member to which the opposite end of the torsion specimen/fixture/adaptor assembly, shown in Fig. 1, can be attached. Either the rotational member or the fixed member shall be free to move axially to prevent the application of axial forces, or the axial force shall be limited to 5 % of the axial strength of the material.

7.3.3 *Drive Mechanism*, for imparting to the movable member a uniform controlled angular velocity with respect to the fixed member. This angular velocity is to be regulated as specified in section 11.6.

7.3.4 *Force Indicator*—A suitable force-indicating mechanism capable of showing the total torsional force carried by the test specimen. This mechanism shall be essentially free of inertia-lag at the specified rate of testing and shall indicate the force within an accuracy of ± 1 % of the actual value, or better.

7.3.5 *Construction Materials*—The fixed member, movable member, drive mechanism, fixtures, and adaptors shall be constructed of such materials and in such proportions that the total rotational deformation of the system contributed by these parts is minimized.

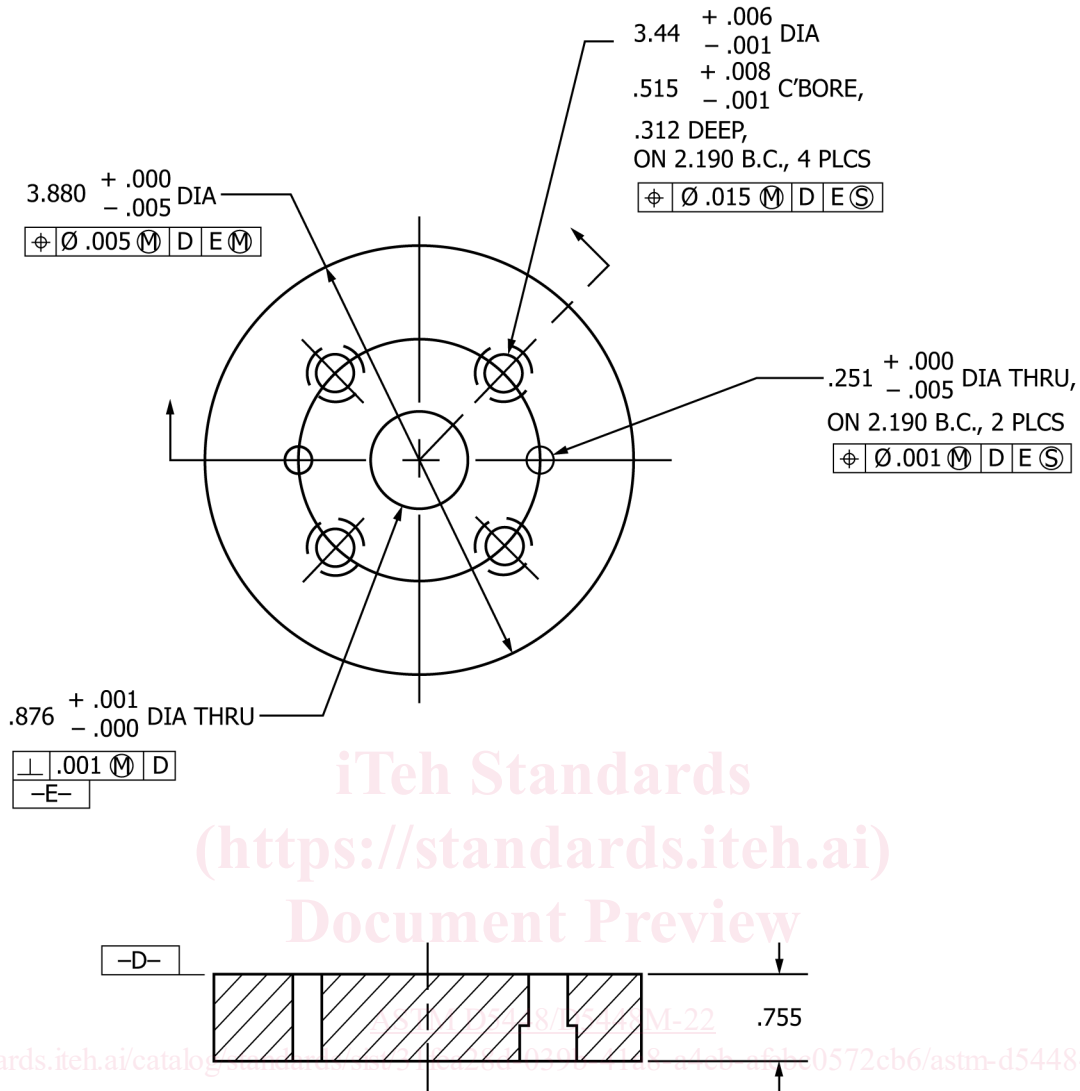

FIG. 5 Insert for the Shear Fixture in Inch-Pound Units

7.4 *Strain-Indicating Device*—Force versus strain data shall be determined by means of bonded resistance strain gauges. Each strain gauge shall be 6.3 mm [0.25 in.] in length. Strain gauge rosettes (0°/45°/90°) shall be used to correct for gauge misalignment. Gauge calibration certification shall comply with Test Method E251. Some guidelines on the use of strain gauges on composites are presented in 7.4.1 – 7.4.4. A general reference on the subject is Tuttle and Brinson.⁴

7.4.1 *Surface Preparation*—The surface preparation of fiber-reinforced composites discussed in Guide E1237 can penetrate the matrix material and cause damage to the reinforcing fibers, resulting in improper specimen failures. Reinforcing fibers should not be exposed or damaged during the surface preparation process. The strain gauge manufacturer should be consulted regarding surface preparation guidelines and recommended bonding agents for composites, pending the development of a set of standard practices for strain gauge installation surface preparation of fiber-reinforced composite materials.

7.4.2 *Gauge Resistance*—Consideration should be given to the selection of gauges having larger resistance to reduce heating effects on low-conductivity materials. Resistances of 350Ω or higher are preferred. Additional considerations should be given to the use of the minimum possible gauge excitation voltage consistent with the desired accuracy (1 to 2 V is recommended) to further reduce the power consumed by the gauge. Heating of the specimen by the gauge may affect

⁴ Tuttle, M. E., and Brinson, H. F., "Resistance-Foil Strain-Gage Technology as Applied to Composite Materials," *Experimental Mechanics*, Vol 24, No. 1, March 1984, pp. 54–64; errata noted in Vol 26, No. 2, January 1986, pp. 153–154.