



Designation: ~~E2730 – 21~~ E2730 – 22

An American National Standard

Standard Guide for Calibration and Use of Thermocouple Reference Junction Probes in Evaluation of Electronic Reference Junction Compensation Circuits¹

This standard is issued under the fixed designation E2730; the number immediately following the designation indicates the year of original adoption or, in the case of revision, the year of last revision. A number in parentheses indicates the year of last reapproval. A superscript epsilon (ϵ) indicates an editorial change since the last revision or reapproval.

1. Scope

1.1 This guide covers methods of calibration and use of thermocouple reference junction probes (cold junction compensation probes) in the evaluation of electronic reference junction compensation circuits. Their use with instruments that measure only voltage is also covered.

1.2 The values stated in SI units are to be regarded as standard. The values given in parentheses after SI units are provided for information only and are not considered standard.

1.3 *This standard does not purport to address all of the safety concerns, if any, associated with its use. It is the responsibility of the user of this standard to establish appropriate safety, health, and environmental practices and determine the applicability of regulatory limitations prior to use.*

1.4 *This international standard was developed in accordance with internationally recognized principles on standardization established in the Decision on Principles for the Development of International Standards, Guides and Recommendations issued by the World Trade Organization Technical Barriers to Trade (TBT) Committee.*

2. Referenced Documents

2.1 ASTM Standards:²

- [E220 Test Method for Calibration of Thermocouples By Comparison Techniques](#)
- [E230/E230M Specification for Temperature-Electromotive Force \(emf\) Tables for Standardized Thermocouples](#)
- [E344 Terminology Relating to Thermometry and Hydrometry](#)
- [E563 Practice for Preparation and Use of an Ice-Point Bath as a Reference Temperature](#)
- [E1129/E1129M Specification for Thermocouple Connectors](#)
- [E1684/E1684M Specification for Miniature Thermocouple Connectors](#)
- [E1750 Guide for Use of Water Triple Point Cells](#)
- [E2623 Practice for Reporting Thermometer Calibrations](#)

2.2 Other References:

- [NIST Monograph 175 Temperature-Electromotive Force Reference Functions and Tables for the Letter-Designated Thermocouple Types Based on the ITS-90³](#)

¹ This guide is under the jurisdiction of ASTM Committee E20 on Temperature Measurement and is the direct responsibility of Subcommittee E20.14 on Thermocouples - Testing.

Current edition approved May 1, 2022. Published July 2022. Originally approved in 2010. Last previous edition approved in 2015 as E2730 – 10 (2015) E2730 – 21. ² DOI:10.1520/E2730-21. DOI:10.1520/E2730-22.

² For referenced ASTM standards, visit the ASTM website, www.astm.org, or contact ASTM Customer Service at service@astm.org. For *Annual Book of ASTM Standards* volume information, refer to the standard's Document Summary page on the ASTM website.

³ Available from National Institute of Standards and Technology (NIST), 100 Bureau Dr., Stop 1070, Gaithersburg, MD 20899-1070, USA, <http://www.nist.gov>.

3. Terminology

3.1 Definitions:

3.1.1 The definitions given in Terminology E344 shall apply to this guide.

3.2 Definitions of Terms Specific to This Standard:

3.2.1 *correction, n*—an offset value added to the result of a measurement to obtain a correct result.

NOTE 1—This definition is from Test Method E220.

3.2.2 *reference junction compensation, n*—the electrical correction of the indication of a thermocouple such that the corrected indication is equivalent to the emf or temperature the instrument would indicate if the reference junctions were physically maintained at 0 °C.

3.2.3 *reference junction probe, n*—a probe constructed from thermocouple materials and high purity copper wire for the purpose of serving as the reference junction for a thermocouple assembly; reference junction probes may be constructed as part of the measuring probe or they can be manufactured separately and later attached to thermocouple sensors via plugs or other connection types.

3.2.4 *UUT, n*—Unit Under Test.

4. Summary of Guide

4.1 Calibration of a Reference Junction Probe (RJP) consists of establishing the emf error in the RJP relative to the applicable thermocouple reference function by placing the measuring junction and the reference junctions at known temperatures while measuring the voltage with a digital voltmeter (DVM) or potentiometer (DVM). Three methods are described for establishing the two known temperatures and thus the temperature difference. For the temperature measurement, many devices such as Standard Platinum Resistance Thermometers (SPRTs), Platinum Resistance Thermometers (PRTs), thermistors, or thermocouples, and a variety of readout instruments are suitable, depending on the required accuracy. The measured voltage at the copper leads indicates the emf associated with the temperature difference of the references. Error is determined by comparing the observed emf to the calculated emf for the known temperature difference. The emf error is then applied as a correction. The corrected emf can then be converted to temperature.

NOTE 2—In particular, cold work should be avoided in the sections of copper and thermocouple wire that pass from the top of the ice bath to ambient temperature continuing on to the terminal connection. Careful design of the RJP, with supporting sleeve and strain relief, can minimize cold work in these sections.

4.2 Use of the calibrated RJP consists of applying the corrections obtained during calibration appropriately for the mode of use. Three modes of use with corresponding application equations are described.

NOTE 3—Homogeneity is assumed in both the thermocouple and copper wires. Care should be taken to minimize the stress induced over time and during use on both sets of wire. Cold work in particular should be avoided in the sections of the copper and thermocouple wire from a distance 5 cm (2 in.) below the top of the ice/water mixture to a distance 5 cm (2 in.) above the top of the ice-point bath.

NOTE 4—Proper operation of the measuring instruments is not described in this guide. To ensure correct results, the operator must understand and apply proper technique in the use of all measuring instruments involved.

5. Significance and Use

5.1 Many electronic instruments that are designed to be used with thermocouples use some method of reference junction compensation. In many industrial applications it may be impractical to use a physical ice bath as a temperature reference in a thermocouple circuit. The instrument must therefore be able to measure the temperature at the point of electrical connection of the thermocouple and either add or subtract voltage to give a corrected equivalent of what that thermocouple would indicate had there

⁴ Available from Pavillon de Breteuil, F-92312 Sèvres Cedex, FRANCE, <https://www.bipm.org/>.

physically been 0 °C reference junctions present in the circuit. There are two types of instruments that generally apply these techniques: electronic thermometer readouts that use a thermocouple as the sensor, and calibrators designed to calibrate these digital thermometer readouts. Additionally, the probe and circuit described in this guide can be used with a voltmeter to emulate a thermometer or a voltage source to calibrate temperature-indicating instrumentation. In all cases the probe must be calibrated if traceability or an uncertainty analysis, or both, is required.

6. Reagents

6.1 Laboratory or commercially produced distilled water is required to create an accurate ice bath. Clean tap water can be used in cases where high accuracy is not a requirement; in this case the temperature of the bath should be measured directly. Chlorine, fluorine, and other chemicals such as dissolved salts in the water or ice will depress the ice point and the amount can be significant in some measurements. See Practice E563 for further guidance.

7. Procedure

7.1 Calibration of RJP (Methods A, B, or C):

7.1.1 Reference Point Temperature Source:

7.1.1.1 Method A: Ice Bath Method—Prepare the reference point temperature source using an ice-point bath in accordance with Practice E563. Refer to Fig. 1.

NOTE 5—Be careful to closely follow the guidelines in Practice E563 for establishing and maintaining an Ice Point Reference as significant error can occur over time without proper maintenance.

7.1.1.2 Method B: Triple Point of Water (TPW) Cell Method—Prepare the reference point temperature source using a triple point of water cell in accordance with Guide E1750. Refer to Fig. 2.

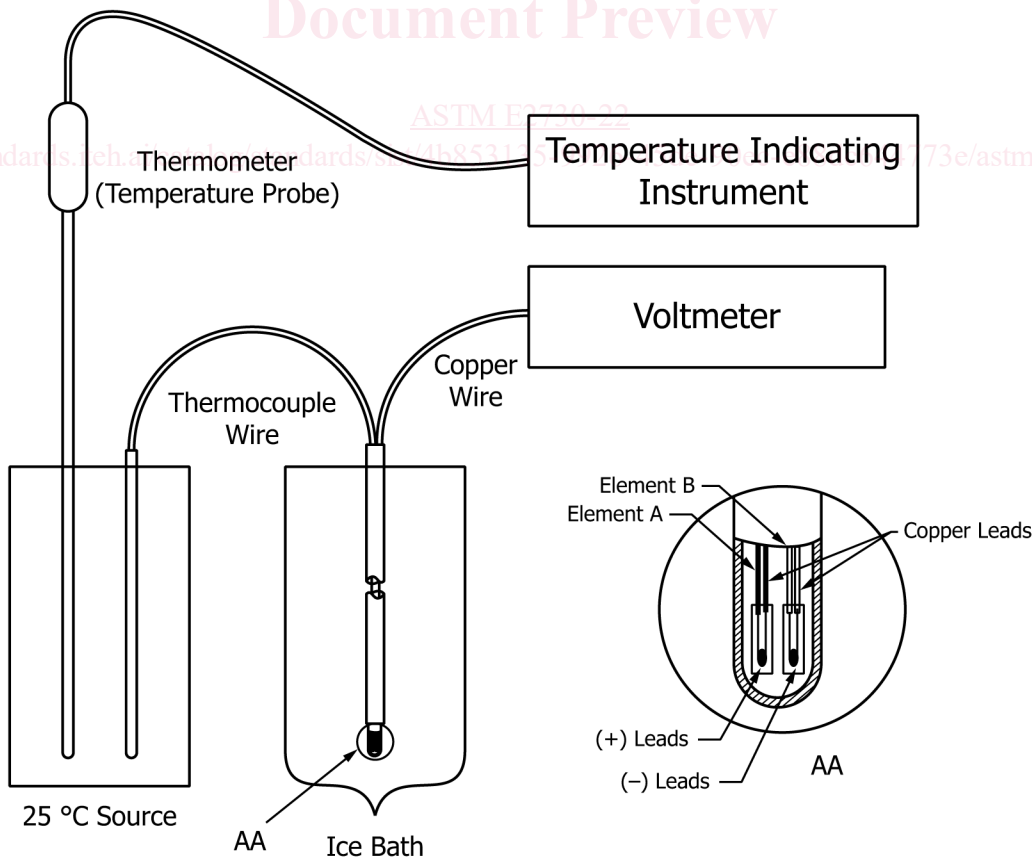

FIG. 1 Schematic Diagram of Calibration Method A

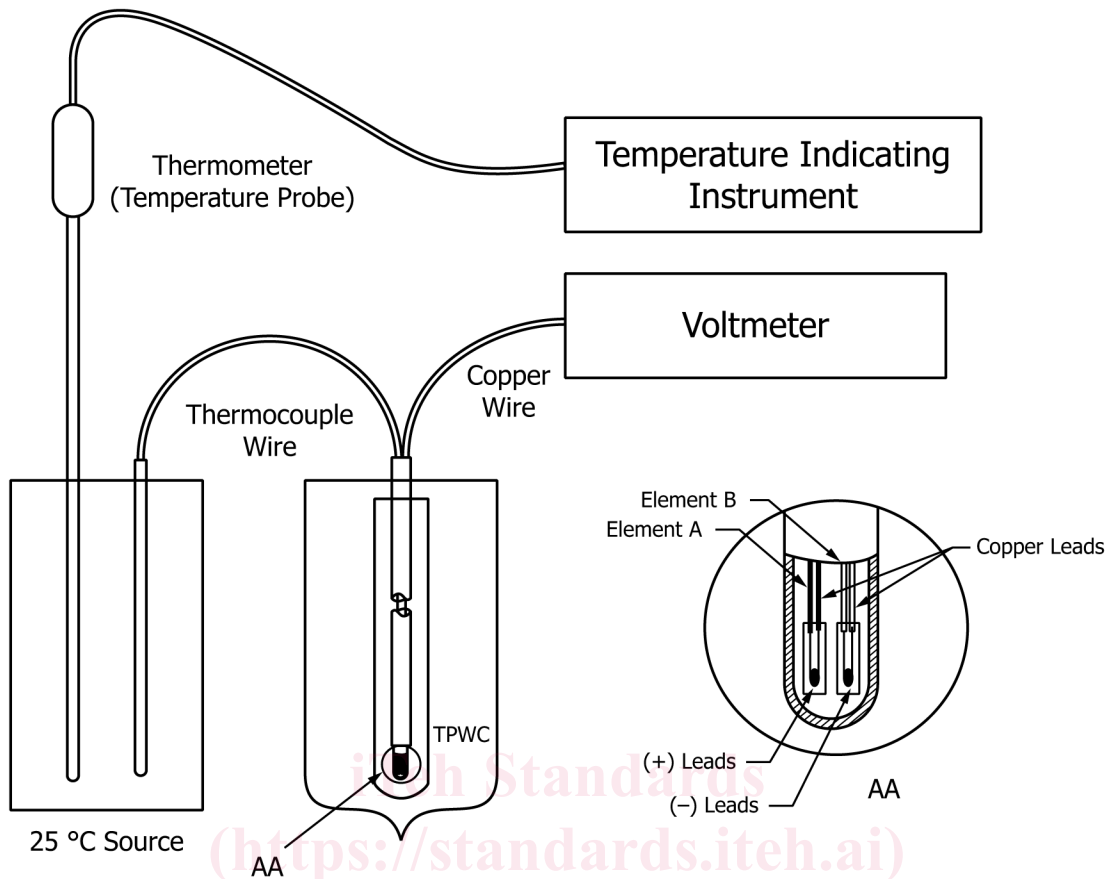

FIG. 2 Schematic Diagram of Calibration Method B

NOTE 6—Be careful to closely follow the guidelines in Guide E1750 for establishing and maintaining a TPW cell as significant error can occur over time without proper maintenance.

7.1.1.3 *Method C: Variable Temperature Source Method*—Prepare the reference point temperature source using a variable temperature source (calibration bath or dryblock calibrator) set to 0.0 °C and verify using a reference thermometer. Refer to Fig. 3.

7.1.2 Prepare the room temperature source using a variable temperature source (calibration bath or dry-block calibrator) set to 25 °C and verify using a reference thermometer. The temperature of 25 °C is nominal; in actual testing the temperature of the bath should be set as close as possible to the ambient room temperature. Throughout this procedure 25 °C will be used to designate the ambient temperature. There are many cases where the terminal ends may be at a temperature higher than ambient temperature. Connections inside an instrument or control box can reach temperatures of 40 °C or higher. The RJP can be calibrated at multiple temperatures and the resulting RJP correction can be modeled as a first- or second-order polynomial correction versus RJP temperature.

7.1.3 Weld, solder, or braze the thermocouple wire ends of the RJP together to create a thermocouple measuring junction and then insert it into a protective sheath. Twisting or crimping the wires is acceptable if a reliable electrical connection can be achieved. The measuring junction should be electrically isolated from the sheath. All fluxes or chemicals that may have been used should be thoroughly removed.

7.1.4 Place the measuring junction and protective sheath in the temperature source that has been stabilized at 25 °C nominal. Place the reference junction probe in the reference point temperature source. Both the sheath and probe should be sufficiently immersed to make stem conduction error negligible. (**Warning**—The individual positive and negative connections must be electrically isolated from each other and the sheath regardless of the type connection or temperature-stabilizing method used.)

7.1.5 Connect the copper leads of the RJP to the voltmeter.

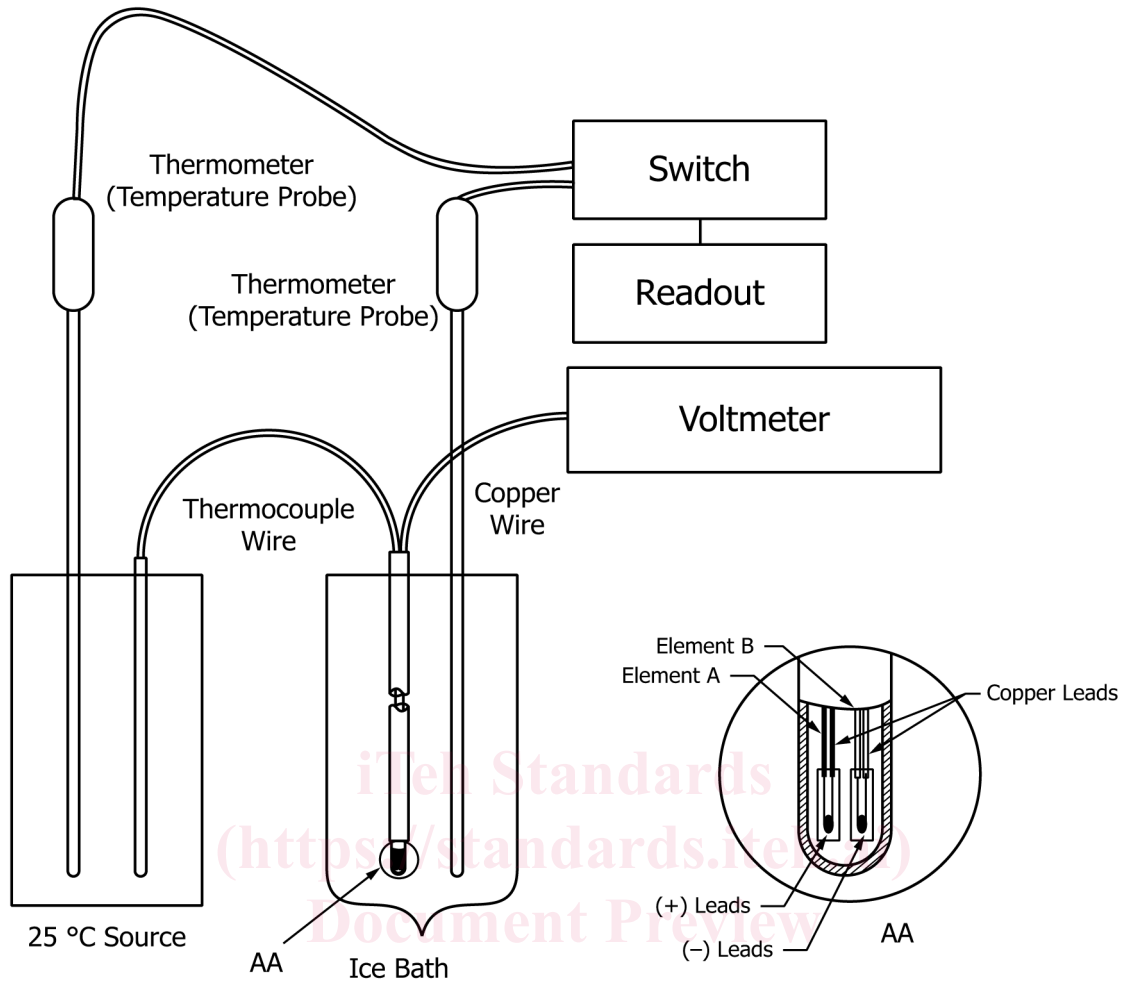

FIG. 3 Schematic Diagram of Calibration Method C

ASTM E2730-22

<https://standards.iteh.ai/catalog/standards/sist/4b853135-9926-45de-90ec-e88dc644773e/astm-e2730-22>

7.1.6 Allow the setup to stabilize as indicated on the voltmeter; the stability required depends upon the level of uncertainty required.

7.1.7 Measure the temperature of the 25 °C source (T_{MJ}) and the reference point temperature source (T_{RJ}) if using Method C.

7.1.8 The RJP error in microvolts is given by Eq 1.

$$E_{RJP\ error} = E_{observed} - \int_{T_{RJ}}^{T_{MJ}} S_{AB}(T) dT \quad (1)$$

where:

$E_{RJP\ error}$ = RJP error in μV ,

$E_{observed}$ = voltage indication in μV ,

T_{MJ} = ambient source temperature in $^{\circ}C$, as measured by the reference thermometer,

T_{RJ} = reference junction temperature in $^{\circ}C$ (assumed to be 0.000 $^{\circ}C$ in Method A, 0.010 $^{\circ}C$ in Method B, and measured by reference thermometer in Method C), and

$S_{AB}(T)$ = Seebeck coefficient at temperature T in $\mu V/^{\circ}C$.

NOTE 7—Use the correct value for the S_{AB} based on the actual temperature of the reference point temperature source. Values given are based on the ice Melting Point (MP) (0.000 $^{\circ}C$).

NOTE 8—The values given are taken from NIST Monograph 175.

TABLE 1 Seebeck Coefficients at 0 °C for Some Common Thermocouple Types^A

Calibration Type	$S_{AB}(0\text{ °C})$ in $\mu\text{V}/\text{°C}$
E	58.666
J	50.382
K	39.456
N	25.929
T	38.748
R	5.290
S	5.403
B	0.102

^A Source—Specification E230/E230M.

7.1.9 The RJP error in microvolts is algebraically approximated using Eq 2 for Method A.

$$E_{RJP\ error} = E_{observed} - E_{expected} \quad (2)$$

where:

- $E_{RJP\ error}$ = RJP error in μV ,
- $E_{observed}$ = voltmeter indication in μV , and
- $E_{expected}$ = thermocouple voltage in μV , at the ambient source temperature, as computed by the reference function or interpolated from the thermocouple table.

7.1.10 The RJP error in microvolts is algebraically approximated using Eq 3 for Method B.

$$E_{RJP\ error} = E_{observed} - E_{expected} + 0.010\text{ °C} \times S_{AB}(0\text{ °C}) \quad (3)$$

where:

- $E_{RJP\ error}$ = RJP error in μV ,
- $E_{observed}$ = voltmeter indication in μV ,
- $E_{expected}$ = thermocouple voltage in μV , at the ambient source temperature, as computed by the reference function or interpolated from the thermocouple table, and
- $S_{AB}(0\text{ °C})$ = Seebeck coefficient at 0 °C in $\mu\text{V}/\text{°C}$ (refer to Table 1).

7.1.11 The RJP error in microvolts is algebraically approximated using Eq 4 for Method C.

$$E_{RJP\ error} = E_{observed} - E_{expected} + S_{AB}(0\text{ °C}) \times T_{RJ} \quad (4)$$

where:

- $E_{RJP\ error}$ = RJP error in μV ,
- $E_{observed}$ = voltmeter indication in μV ,
- $E_{expected}$ = thermocouple voltage in μV , at the ambient source temperature, as computed by the reference function or interpolated from the thermocouple table,
- T_{RJ} = reference junction temperature in °C , as measured by the reference thermometer, and
- $S_{AB}(0\text{ °C})$ = Seebeck coefficient at 0 °C in $\mu\text{V}/\text{°C}$ (refer to Table 1).

7.1.12 Corrections are identical to errors in magnitude but of opposite sign. Calculate the voltage correction in μV using Eq 5.

$$E_{RJP\ correction} = E_{RJP\ error} \quad (5)$$

where:

- $E_{RJP\ correction}$ = RJP correction in μV , and
- $E_{RJP\ error}$ = RJP error in μV .

7.1.13 Calculate the temperature correction in °C using Eq 6.

$$T_{RJP\ correction} = \frac{-(E_{RJP\ error})}{S_{AB}(0\text{ °C})} \quad (6)$$

where:

$T_{RJP\ correction}$ = RJP correction in °C,

$E_{RJP\ error}$ = RJP error in μV , and

$S_{AB}(0\text{ }^\circ\text{C})$ = Seebeck coefficient at temperature 0 °C, in $\mu\text{V}/^\circ\text{C}$ (refer to Table 1).

(Warning—Eq 6 may provide incorrect results for thermocouples having significantly different values of S_{AB} at 0 °C and 25 °C.)

7.2 Use of the RJP (Modes 1, 2, or 3).

NOTE 9—The following instructions apply to the use of an ice bath, TPW cell, or variable temperature source for the reference point temperature. Thus, the equations are shown in the generalized form. When using the equations, the value for T_{RJ} must be the assumed values for the ice bath or TPW cell, or the actual measured temperature of the variable temperature source, as applicable.

7.2.1 Mode 1—Use of the RJP as a reference junction in a thermocouple circuit. Refer to Fig. 4.

7.2.1.1 Prepare the reference point temperature source.

7.2.1.2 Connect the thermocouple end of the RJP to the thermocouple to be measured using an approved thermocouple connector.

7.2.1.3 Connect the copper wire end of the RJP to the measuring instrument, observing polarity.

7.2.1.4 Place the RJP probe into the reference point temperature source.

7.2.1.5 Place the thermocouple measuring junction in the location to be measured.

7.2.1.6 Allow sufficient time for the indications to stabilize.

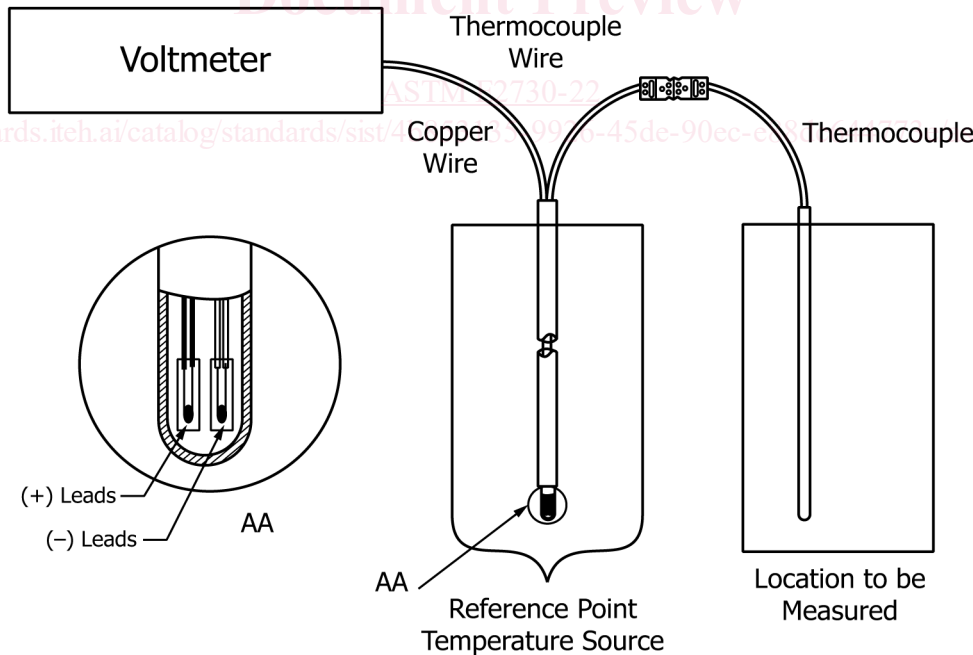

FIG. 4 Schematic Diagram of Usage Mode 1