



Designation: D4592 – 12 (Reapproved 2022)

Standard Specification for Preformed Retroreflective Pavement Marking Tape for Limited Service Life¹

This standard is issued under the fixed designation D4592; the number immediately following the designation indicates the year of original adoption or, in the case of revision, the year of last revision. A number in parentheses indicates the year of last reapproval. A superscript epsilon (ϵ) indicates an editorial change since the last revision or reapproval.

1. Scope

1.1 This specification covers white or yellow preformed retroreflective pavement marking tapes that are designed to provide a service life of typically three to six months, depending on wear and durability factors.

1.2 The tapes are intended for use as longitudinal, transverse, or word/symbol pavement markings that provide delineation day and night. The tapes may be either removable or nonremovable.

1.3 The values stated in inch-pound units are to be regarded as the standard except where noted in the document. The values given in parentheses are mathematical conversions to SI units that are provided for information only and are not considered standard.

1.4 *This international standard was developed in accordance with internationally recognized principles on standardization established in the Decision on Principles for the Development of International Standards, Guides and Recommendations issued by the World Trade Organization Technical Barriers to Trade (TBT) Committee.*

2. Referenced Documents

2.1 *ASTM Standards:*²

[D1000 Test Methods for Pressure-Sensitive Adhesive-Coated Tapes Used for Electrical and Electronic Applications](#)

[D4061 Test Method for Retroreflectance of Horizontal Coatings](#)

[D6628 Specification for Color of Pavement Marking Materials](#)

[E303 Test Method for Measuring Surface Frictional Properties Using the British Pendulum Tester](#)

[E1710 Test Method for Measurement of Retroreflective Pavement Marking Materials with CEN-Prescribed Geometry Using a Portable Retroreflectometer](#)

2.2 *Federal Standard:*³

[Fed Std Test Method 141](#)

2.3 *CIE Publications:*⁴

[No. 15.2 Colorimetry](#)

[No. 39.2 Recommendations for Surface Colours for Visual Signaling](#)

3. Terminology

3.1 *Definitions:*

3.1.1 *limited service life or period*—a minimum service period of three months when placed in accordance with the manufacturer's recommended procedures on pavement surfaces.

NOTE 1—See Section 7 for factors affecting durability.

3.1.2 *preformed tape*—continuous, flexible pavement marking material that is essentially complete and that may be affixed to or imbedded in the road surface without fundamentally altering its configuration.

3.1.3 *retroreflection*—reflection in which radiation is returned in directions close to the direction from which it came, this property being maintained over wide variations of the direction of the incident radiation.

3.1.4 *retroreflector*—surface or device that reflects and returns a relatively high proportion of light in a direction close to the light source. This characteristic is maintained over a wide variation of the angle made by the incident light ray and the normal to the retroreflective surface.

3.1.5 *surface pattern*—a pattern on the surface with areas of raised surface area.

4. Classification

4.1 Pavement marking tape manufactured according to this specification shall be identified as Type I or Type II:

³ Available from Naval Publications and Forms Center, 5801 Tabor Ave, Philadelphia, PA 19120.

⁴ Available from U.S. National Committee of the CIE (International Commission on Illumination), c/o Thomas M. Lemons, TLA-Lighting Consultants, Inc., 7 Pond St., Salem, MA 01970, <http://www.cie-usnc.org>.

¹ This specification is under the jurisdiction of ASTM Committee D04 on Road and Paving Materials and is the direct responsibility of Subcommittee D04.38 on Highway Traffic Control Materials.

Current edition approved May 1, 2022. Published May 2022. Originally approved in 1986. Last previous edition approved in 2017 as D4592 – 12 (2017). DOI: 10.1520/D4592-12R22.

² For referenced ASTM standards, visit the ASTM website, www.astm.org, or contact ASTM Customer Service at service@astm.org. For *Annual Book of ASTM Standards* volume information, refer to the standard's Document Summary page on the ASTM website.

4.1.1 *Type I (Removable)*—Marking tapes, after serving the intended limited service life, shall be removable from asphalt or portland cement concrete surfaces at pavement temperatures above 40 °F (4 °C) intact or in pieces no less than about 93 in.² (600 cm²) in area, either manually or with a mechanical device without the use of heat, solvents, grinding, or blasting that would damage or discolor the pavement so as to leave an impressed traffic lane mark.

4.1.2 *Type II (Nonremovable)*—This type of tape shall not be required to have removal characteristics as in 4.1.1.

NOTE 2—Type II tapes are most often used for short-term applications in which markings are paved over during successive road construction operations.

5. Ordering Information

5.1 The purchaser using this specification shall include the following information:

- 5.1.1 ASTM designation (D4592),
- 5.1.2 Classification Type (I or II; see 4.1),
- 5.1.3 Daytime color (see 6.3),
- 5.1.4 Width and length of rolls, and
- 5.1.5 Any additional information.

6. Requirements

6.1 Physical Requirements:

6.1.1 The marking tape shall be a reflective film coated with a pressure-sensitive adhesive with or without a protective liner.

6.1.2 The marking tape shall be flexible and shall conform to the typical road pavement surface.

6.1.3 The marking tape shall adhere to asphalt or portland cement concrete roadway surfaces when applied according to the manufacturer’s recommended procedures on pavement surfaces having temperatures down to 50 °F (10 °C) at the time of application.

6.1.4 Immediately following application, the tape shall not require a cure or set time prior to opening to traffic.

6.1.5 The tape as supplied shall be free of cracks, and have true, straight, and unbroken edges. The actual width of rolls of preformed marking tape used for striping shall be no less than the nominal (stated) width and no more than 1/8 in. (3 mm) greater than the nominal width. The length shall be no less than the stated length.

6.2 Retroreflection:

6.2.1 The marking tape shall be retroreflective, reflecting white or yellow, respectively, and shall be readily visible when viewed with automobile headlights at night and shall have minimum reflective values as shown in Table 1 when measured in accordance with the photometric testing procedures of Test Method D4061 or E1710.

NOTE 3—Retroreflectance may be dependent on the direction in which

TABLE 1 Reflectivity Values for Dry Samples^A

| Entrance Angle | Observation Angle | Minimum Reflective Value, (RL) | |
|----------------|-------------------|--------------------------------|--------|
| | | White | Yellow |
| 88.76° | 1.05° | 500 | 300 |

^A Minimum Retroreflectivity (RL) mcd m⁻² lx⁻¹ (mcd ft⁻² (fc)⁻¹).

the material is manufactured (in other words, upweb R_L may differ from downweb R_L).

6.2.2 The retroreflectance of the marking tape shall be measured in one roll-winding direction and then re-measured in the opposite direction. Both measured values shall comply with the stated R_L minimum.

6.2.3 Reflective values shall be expressed as coefficient of retroreflected luminance (R_L) in millicandelas per square meter per lux (millicandelas per square foot per footcandle).

NOTE 4—The values presented for the coefficient of retroreflected luminance (R_L) are presented in SI units, which are the accepted worldwide norm for expressing this value, rather than inch-pound.

6.3 Color:

6.3.1 The white and yellow marking tape shall conform to the requirements of Specification D6628.

6.4 Adhesion:

6.4.1 A sample of tape, 1 in. (25.4 mm) in width, applied according to the manufacturer’s recommended procedure and tested in accordance with Test Methods D1000, shall have minimum adhesion values as shown in Table 2.

6.5 Skid Resistance:

6.5.1 The Type I marking tape shall have an average minimum frictional resistance value of 45 BPN (British Pendulum Number) when tested according to Test Method E303.

NOTE 5—Skid resistance is not required for Type II nonremovable tapes that are typically applied for a short duration and then paved over.

NOTE 6—Skid resistance levels of 45 BPN correspond to tapes having exposed retroreflective glass beads. Higher levels of skid resistance are achievable with the addition of skid-resistant elements.

NOTE 7—For tapes with a surface pattern, results are often quite variable. These tapes may be tested in a direction parallel to the flow of traffic and 45° from the direction of traffic, and the results averaged.

7. Durability and Wear Resistance

7.1 Factors Affecting Durability and Wear Resistance:

7.1.1 Features of the pavement marking tape, such as thickness and wear surface material, may affect durability. In general, thicker materials wear longer than thinner materials of the same composition. Wear surfaces composed of harder materials, such as urethanes, may be more durable than those made of softer materials, like vinyl.

7.1.2 Roadway characteristics affect durability. Rough road surfaces, porous surfaces, and high traffic volumes tend to decrease service life of markings. A high percentage of large vehicles tends to decrease service life. Locations where vehicles encroach or turn on the markings decrease service life. Techniques and materials used for control of ice and snow also affect durability.

TABLE 2 Adhesion

| Application Temperature °F (°C) | Test Temperature °F (°C) | Minimum Adhesion, N |
|---------------------------------|--------------------------|---------------------|
| 50 (10) | 50 (10) | 4.88 |
| 75 (24) | 75 (24) | 4.88 |
| 115 (46) | 115 (46) | 4.88 |

7.2 Because no practical laboratory procedures have been determined to provide complete, reliable, predictive information on durability and wear resistance, the user is encouraged to seek information from alternate sources.

NOTE 8—The National Transportation Product Evaluation Program, administered by AASHTO, publishes data on the durability of many pavement marking tapes gathered from various annual test decks. These decks feature a wide variety of conditions, which may or may not be applicable to the user's needs.

8. Storage

8.1 *Storage Characteristics*—The marking tape as supplied shall have a minimum shelf life of one year from the date of purchase when stored at temperatures between 50 and 100 °F (10 and 38 °C).

9. Packaging and Marking

9.1 The marking tape shall be packaged in rolls and there shall be no more than three splices/164 ft (50 m) of length.

9.2 The tape shall be packaged in accordance with accepted commercial standards.

10. Keywords

10.1 pavement marking; pavement marking tape; retroreflectance; tape

APPENDIX

(Nonmandatory Information)

X1. DISCUSSION OF “30-METRE” GEOMETRY

X1.1 The European Committee for Standardization (CEN) originally developed the geometry used in this standard for measuring the retroreflectance of preformed tape (entrance angle 88.76° and observation angle 1.05°). The angles were derived using theoretically typical heights for headlamps and

drivers' eyes. These heights were further simplified by assuming a single headlamp is mounted directly under the driver's eye (see Fig. X1.1). The geometry is considered a good approximation for drivers viewing preformed tape on a flat road, 30 m ahead of a car.

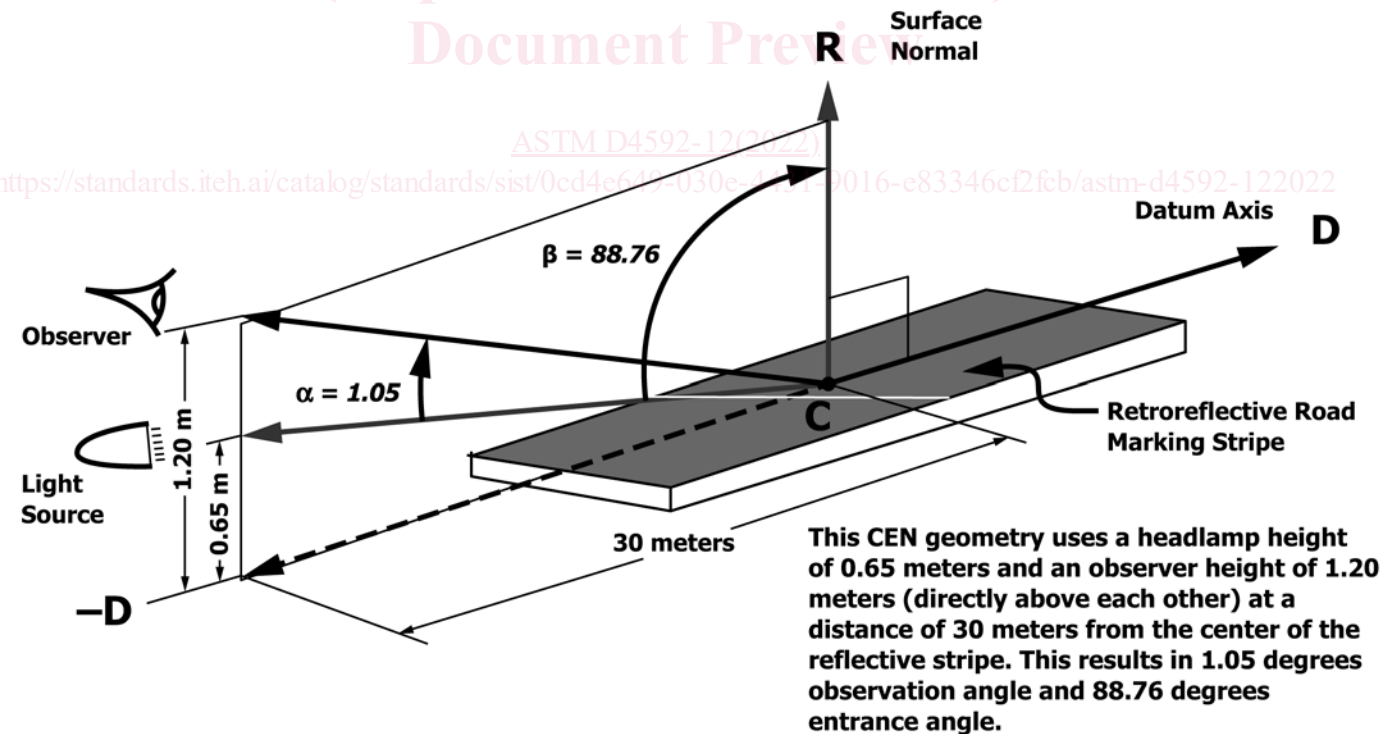

FIG. X1.1 CEN 30-Metre Geometry