



Designation: D7336/D7336M – 22

# Standard Test Method for Static Energy Absorption Properties of Honeycomb Sandwich Core Materials<sup>1</sup>

This standard is issued under the fixed designation D7336/D7336M; the number immediately following the designation indicates the year of original adoption or, in the case of revision, the year of last revision. A number in parentheses indicates the year of last reapproval. A superscript epsilon ( $\epsilon$ ) indicates an editorial change since the last revision or reapproval.

## 1. Scope

1.1 This test method determines the static energy absorption properties (compressive crush stress and crush stroke) of honeycomb sandwich core materials. These properties are usually determined for design purposes in a direction normal to the plane of the face sheets (also referred to as the facing plane) as the honeycomb core material would be placed in a structural sandwich construction.

1.2 Permissible core materials are limited to those in honeycomb form.

1.3 This test method is not intended for use in crush testing of stabilized honeycomb core materials (for which the facing plane surfaces of the honeycomb core material are dipped in resin to resist local crushing) or sandwich specimens (for which facings are bonded to the honeycomb core material).

1.4 *Units*—The values stated in either SI units or inch-pound units are to be regarded separately as standard. The values stated in each system are not necessarily exact equivalents; therefore, to ensure conformance with the standard, each system shall be used independently of the other, and values from the two systems shall not be combined.

1.4.1 Within the text, the inch-pound units are shown in brackets.

1.5 *This standard does not purport to address all of the safety concerns, if any, associated with its use. It is the responsibility of the user of this standard to establish appropriate safety, health, and environmental practices and determine the applicability of regulatory limitations prior to use.*

1.6 *This international standard was developed in accordance with internationally recognized principles on standardization established in the Decision on Principles for the Development of International Standards, Guides and Recommendations issued by the World Trade Organization Technical Barriers to Trade (TBT) Committee.*

<sup>1</sup> This test method is under the jurisdiction of ASTM Committee D30 on Composite Materials and is the direct responsibility of Subcommittee D30.09 on Sandwich Construction.

Current edition approved May 1, 2022. Published May 2022. Originally approved in 2007. Last previous edition approved in 2016 as D7336/D7336M – 16. DOI: 10.1520/D7336\_D7336M-22.

## 2. Referenced Documents

2.1 *ASTM Standards*:<sup>2</sup>

[C271/C271M Test Method for Density of Sandwich Core Materials](#)

[D883 Terminology Relating to Plastics](#)

[D3878 Terminology for Composite Materials](#)

[D5229/D5229M Test Method for Moisture Absorption Properties and Equilibrium Conditioning of Polymer Matrix Composite Materials](#)

[E4 Practices for Force Calibration and Verification of Testing Machines](#)

[E6 Terminology Relating to Methods of Mechanical Testing](#)

[E18 Test Methods for Rockwell Hardness of Metallic Materials](#)

[E122 Practice for Calculating Sample Size to Estimate, With Specified Precision, the Average for a Characteristic of a Lot or Process](#)

[E177 Practice for Use of the Terms Precision and Bias in ASTM Test Methods](#)

[E456 Terminology Relating to Quality and Statistics](#)

## 3. Terminology

3.1 *Definitions*—Terminology [D3878](#) defines terms relating to high-modulus fibers and their composites, as well as terms relating to sandwich constructions. Terminology [D883](#) defines terms relating to plastics. Terminology [E6](#) defines terms relating to mechanical testing. Terminology [E456](#) and Practice [E177](#) define terms relating to statistics. In the event of a conflict between terms, Terminology [D3878](#) shall have precedence over the other terminologies.

NOTE 1—If the term represents a physical quantity, its analytical dimensions are stated immediately following the term (or letter symbol) in fundamental dimension form, using the following ASTM standard symbology for fundamental dimensions, shown within square brackets:  $[M]$  for mass,  $[L]$  for length,  $[T]$  for time,  $[\theta]$  for thermodynamic temperature, and  $[nd]$  for non-dimensional quantities. Use of these symbols is restricted to analytical dimensions when used with square brackets, as the symbols may have other definitions when used without the brackets.

<sup>2</sup> For referenced ASTM standards, visit the ASTM website, [www.astm.org](http://www.astm.org), or contact ASTM Customer Service at [service@astm.org](mailto:service@astm.org). For *Annual Book of ASTM Standards* volume information, refer to the standard's Document Summary page on the ASTM website.



### 3.2 Definitions of Terms Specific to This Standard:

3.2.1 *cell size [L], n*—in a honeycomb core, the distance between two parallel and opposite cell walls at node bond areas, measured transverse to the ribbon direction.

3.2.2 *node bond area, n*—in a honeycomb core, the area between two cells at which the component walls of the cells are bonded or attached.

### 3.3 Symbols:

$A$	= cross-sectional area of a test specimen prior to compressive crush testing
$CV$	= coefficient of variation statistic of a sample population for a given property (in percent)
$K_A$	= initial chord slope of the force versus displacement/deformation curve
$K_B$	= post-crush slope of the force versus displacement/deformation curve
$P_{cr}$	= average force carried by test specimen during compressive crushing
$s_{cr}$	= crush stroke in percent
$S_{n-1}$	= standard deviation statistic of a sample population for a given property
$t_i$	= thickness of a test specimen prior to compressive crush testing
$x_1$	= test result for an individual specimen from the sample population for a given property
$\bar{x}$	= mean or average (estimate of mean) of a sample population for a given property
$\delta$	= recorded displacement/deflection
$\delta_A$	= displacement/deflection at which the initial chord slope intersects the displacement/deformation axis
$\delta_B$	= displacement/deflection at which the post-crushing slope equals the initial chord slope
$\delta_{cr}$	= crush stroke
$\Delta$	= normalized displacement/deflection
$\sigma_{cr}$	= average compressive crush stress

## 4. Summary of Test Method

4.1 This test method consists of subjecting a sandwich honeycomb core material to a uniaxial compressive force normal to the plane of the face sheets as the honeycomb core material would be placed in a structural sandwich construction. The force is transmitted to the sandwich honeycomb core material using loading platens attached to the testing machine. Compressive force is applied past the initial failure force, such that the honeycomb core material is crushed under continuous displacement of the loading platens. Force versus loading platen displacement data are recorded and used to determine the crush stress and crush stroke.

## 5. Significance and Use

5.1 Sandwich honeycomb core materials are used extensively in energy absorption applications, due to their ability to sustain compressive loading while being crushed. Proper design of energy absorption devices utilizing sandwich honeycomb core materials requires knowledge of the compressive crush stress and crush stroke properties of the honeycomb core material.

5.2 The procedures contained within this test method are intended to assess the crush stress and crush stroke properties of the sandwich honeycomb core material under static compressive loading. The dynamic crush stress of the honeycomb core material may vary from that measured under static loading, depending upon factors such as honeycomb core material thickness, core material density, impact velocity, etc.

5.3 This test method provides a standard method of obtaining the compressive crush stress and crush stroke for sandwich honeycomb core material structural design properties, material specifications, research and development applications, and quality assurance.

5.4 This test method is not intended for use in crush testing of stabilized honeycomb core materials (for which the facing plane surfaces of the honeycomb core material are dipped in resin to resist local crushing) or sandwich specimens (for which face sheets are bonded to the honeycomb core material).

5.5 Factors that influence the compressive crush stress and crush stroke and shall therefore be reported include the following: honeycomb core material, methods of material fabrication, core material geometry (nominal cell size), core material density, specimen geometry, specimen preparation, specimen conditioning, environment of testing, specimen alignment, pre-crush procedure, pre-crush depth, loading procedure, and speed of testing.

## 6. Interferences

6.1 *Material and Specimen Preparation*—Poor material fabrication practices and damage induced by improper specimen machining are known causes of high data scatter in composites and sandwich structures in general. Important aspects of sandwich core material specimen preparation that contribute to data scatter include the existence of joints, voids or other core material discontinuities, out-of-plane curvature/warpage, and surface roughness.

6.2 *System Alignment*—Non-uniform loading over the surface of the test specimen may cause premature or uneven crushing. This may occur as a result from non-uniform thickness, failing to locate the specimen concentrically in the fixture, or system or fixture misalignment.

6.3 *Geometry*—Specific geometric factors that affect compressive crush stress and crush stroke include honeycomb core material cell geometry, core material thickness, and specimen shape (square or circular). Thicker specimens are generally desirable, as the crush stroke is greater for thick specimens compared to thin specimens.

6.4 *Pre-Crushing*—It is recommended to pre-crush honeycomb core material specimens prior to test, as historical crush force versus displacement data for pre-crushed specimens have displayed greater uniformity (consistency of the crush force level for varying crush stroke) than have similar data for non pre-crushed specimens. If tests are performed using analog equipment to record force versus displacement data, pre-crushing may be necessary to ensure the crush force is recorded on a high sensitivity force scale (if not pre-crushed, the peak force to initially fail the specimen may be substantially higher

than the crush force). Pre-crushing also aids interpretation of force versus displacement data and calculation of crush stroke values. Results are affected by the pre-crush depth and uniformity of pre-crushing.

6.5 *Environment*—Results are affected by the environmental conditions under which specimens are conditioned, as well as the conditions under which the tests are conducted. Specimens tested in various environments can exhibit significant differences in both crush stress and crush stroke. Critical environments must be assessed independently for each honeycomb core material tested.

## 7. Apparatus

7.1 *Micrometers and Calipers*—A micrometer having a flat anvil interface, or a caliper of suitable size, shall be used. The accuracy of the instrument(s) shall be suitable for reading to within 1 % of the sample length and width (or diameter) and thickness. For typical specimen geometries, an instrument with an accuracy of  $\pm 250 \mu\text{m}$  [ $\pm 0.010 \text{ in.}$ ] is desirable for thickness, length and width (or diameter) measurement.

7.2 *Loading Platens*—Force shall be introduced into the specimen using fixed flat platens (58 HRC minimum as specified in Test Methods E18). One platen may be of the spherical seat (self-aligning) type, if it is capable of being locked in a fixed position once the platen has contacted and aligned with the specimen. The platens shall be well-aligned (centered with respect to the drive mechanism loading train) and shall not apply eccentric forces. A satisfactory type of apparatus is shown in Figs. 1 and 2. The platen surfaces shall extend beyond the test specimen periphery. If the platens are not sufficiently hardened, or simply to protect the platen surfaces, a hardened plate (with parallel surfaces) can be inserted between each end of the specimen and the corresponding platen.

7.3 *Testing Machine*—The testing machine shall be in accordance with Practices E4 and shall satisfy the following requirements:

7.3.1 *Testing Machine Configuration*—The testing machine shall have both an essentially stationary head and a movable head.

7.3.2 *Drive Mechanism*—The testing machine drive mechanism shall be capable of imparting to the movable head a controlled velocity with respect to the stationary head. The velocity of the movable head shall be capable of being regulated in accordance with 11.6.

7.3.3 *Load Indicator*—The testing machine load-sensing device shall be capable of indicating the total force being carried by the test specimen. This device shall be essentially free from inertia lag at the specified rate of testing and shall indicate the force with an accuracy over the force range(s) of interest of within  $\pm 1 \%$  of the indicated value.

7.3.4 *Crosshead Displacement Indicator*—The testing machine shall be capable of monitoring and recording the crosshead displacement (stroke) with a precision of at least  $\pm 1 \%$ . If machine compliance is significant, it is acceptable to measure the displacement of the movable head using a LVDT, compressometer or similar device with  $\pm 1 \%$  precision on

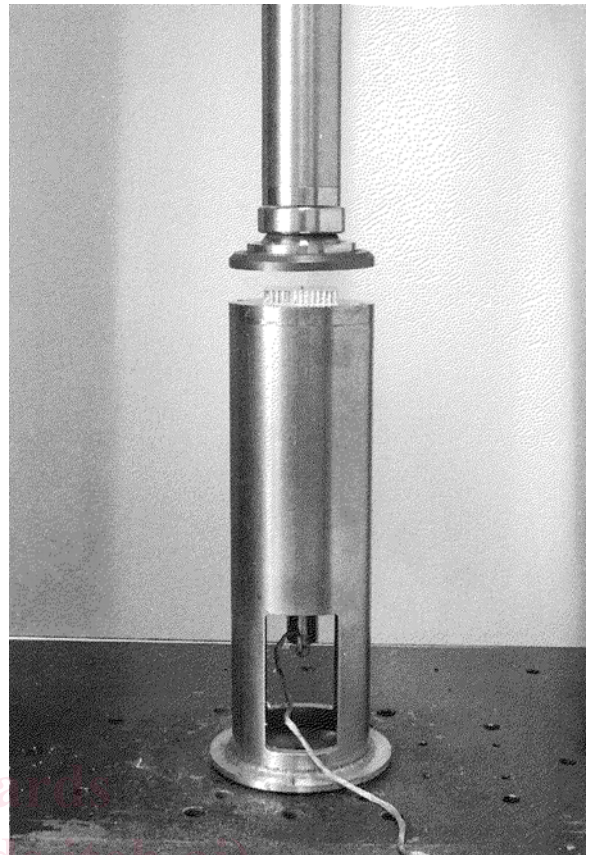

**FIG. 1 Platen with Transducer and Rod Setup**



**FIG. 2 Close-up of Specimen Between Loading Platens Being Crushed**

displacement. A transducer and rod setup, shown in Figs. 1 and 2, has been found to work satisfactorily. In the example shown, a small hole is drilled in the center of the bottom loading platen, and a transducer rod is inserted through the hole and the honeycomb core test specimen, such that it contacts the upper loading platen. If such an apparatus is used, the transducer rod diameter shall be no greater than the cell size, so that the

transducer rod can be inserted through the test specimen without distorting the core cell geometry.

7.4 *Conditioning Chamber*—When conditioning materials at non-laboratory environments, a temperature/vapor-level controlled environment conditioning chamber is required that shall be capable of maintaining the required temperature to within  $\pm 3\text{ }^{\circ}\text{C}$  [ $\pm 5\text{ }^{\circ}\text{F}$ ] and the required relative humidity level to within  $\pm 3\%$  RH. Chamber conditions shall be monitored either on an automated continuous basis or on a manual basis at regular intervals.

7.5 *Environmental Test Chamber*—An environmental test chamber is required for testing environments other than ambient testing laboratory conditions. This chamber shall be capable of maintaining the gauge section of the test specimen at the required test environment during the mechanical test. The test temperature shall be maintained within  $\pm 3\text{ }^{\circ}\text{C}$  [ $\pm 5\text{ }^{\circ}\text{F}$ ] of the required temperature, and the relative humidity level shall be maintained to within  $\pm 3\%$  RH of the required humidity level.

7.6 *Pre-Crushing Device*—Crush strength and stroke data for pre-crushed honeycomb core materials typically display greater uniformity than have similar data for non pre-crushed specimens. Serrated plates have been used successfully as pre-crushing devices for honeycomb core materials; acceptable reference serrated plate configurations are shown in Figs. 3 and 4. The pre-crushing device must be capable of providing a relatively uniform pre-crush depth of  $1.0 \pm 0.5\text{ mm}$  [ $0.03 \pm 0.02\text{ in.}$ ].

8. Sampling and Test Specimens

8.1 *Sampling*—Test at least five specimens per test condition unless valid results can be gained through the use of fewer specimens, as in the case of a designed experiment. For statistically significant data, consult the procedures outlined in Practice E122. Report the method of sampling.

8.2 *Geometry*—Test specimens shall have a square or circular cross-section and a minimum thickness of 25 mm [1.0 in.]. The required facing area of the specimen is dependent upon the cell size, to ensure a minimum number of cells are tested. Minimum facing areas are recommended in Table 1 for the more common cell sizes. These are intended to provide approximately 60 cells minimum in the test specimen. The largest facing area listed in the table ( $5625\text{ mm}^2$  [9.0 in.<sup>2</sup>]) is a practical maximum for this test method. Core materials with cell sizes larger than 9 mm [0.375 in.] may require a smaller number of cells to be tested in the specimen.

NOTE 2—The specimen’s cross-sectional area is defined in the facing plane, in regard to the orientation that the honeycomb core material would be placed in a structural sandwich construction. For a honeycomb core material, the cross-sectional area is defined in the plane of the cells, which is perpendicular to the orientation of the cell walls.

8.3 *Specimen Preparation and Machining*—Prepare the test specimens so that the reference loading surfaces are parallel to each other and perpendicular to the sides of the specimen. Take precautions when cutting specimens from large sheets of honeycomb core material to avoid notches, undercuts, rough or uneven surfaces due to inappropriate machining methods. Obtain final dimensions by water-lubricated precision sawing,

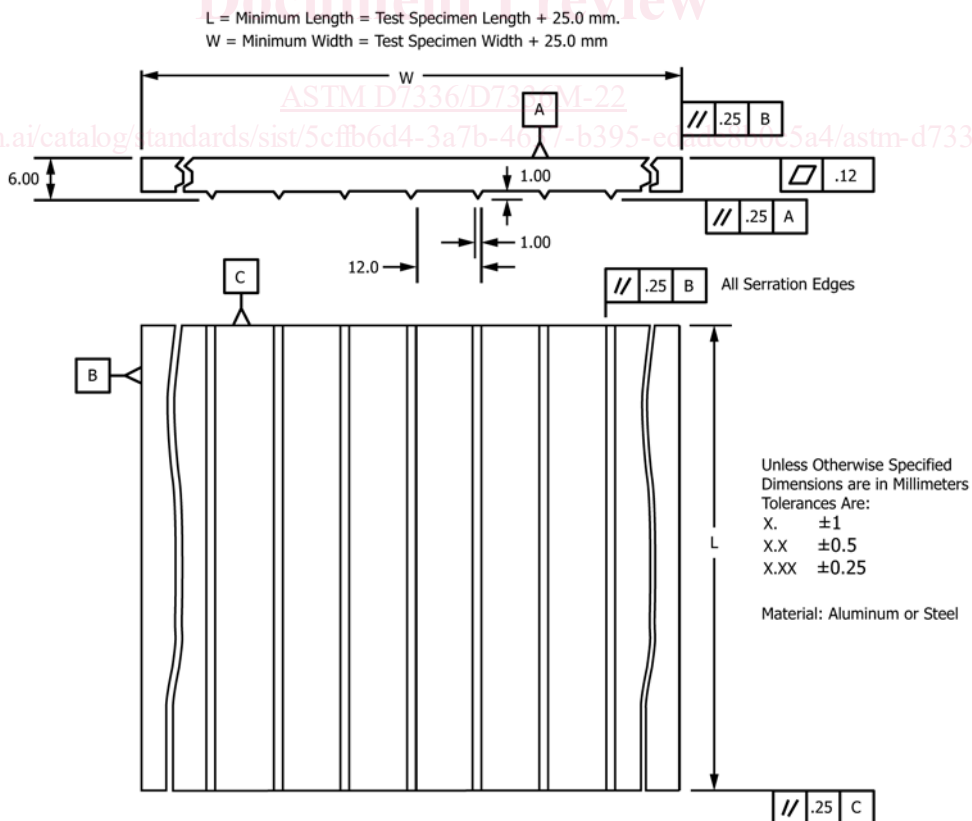

FIG. 3 Representative Serrated Plate for Honeycomb Core Material Pre-Crushing (SI Version)

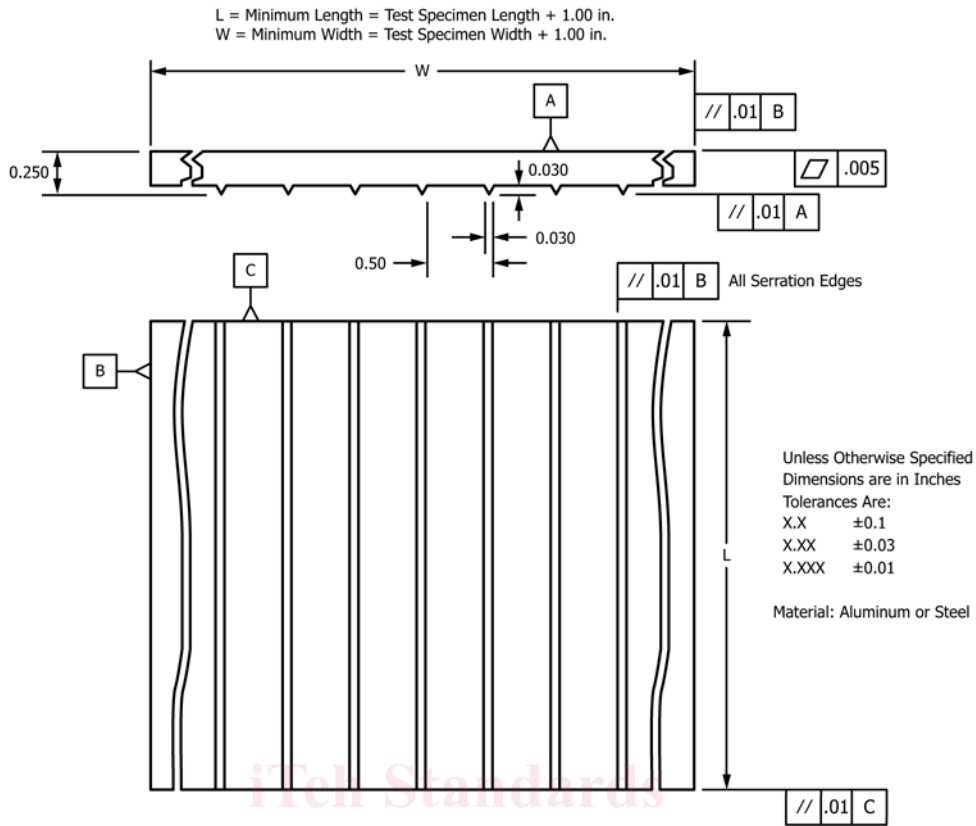

FIG. 4 Representative Serrated Plate for Honeycomb Core Material Pre-Crushing (Inch-Pound Version)

TABLE 1 Recommended Minimum Specimen Cross-Sectional Area

Minimum Cell Size (mm [in.])	Maximum Cell Size (mm [in.])	Minimum Cross-Sectional Area (mm <sup>2</sup> [in. <sup>2</sup> ])
—	3.0 [0.125]	625 [1.0]
3.0 [0.125]	6.0 [0.250]	2500 [4.0]
6.0 [0.250]	9.0 [0.375]	5625 [9.0]

milling, or grinding. The use of diamond tooling has been found to be extremely effective for many material systems. Record and report the specimen cutting preparation method.

8.4 If honeycomb core material density is to be reported, samples used to determine density shall be obtained from the same sheet of honeycomb core material being tested. Density may be evaluated in accordance with Test Method C271/C271M.

8.5 *Labeling*—Label the test specimens so that they will be distinct from each other and traceable back to the sheet of origin, and will neither influence the test nor be affected by it.

## 9. Calibration

9.1 The accuracy of all measuring equipment shall have certified calibrations that are current at the time of use of the equipment.

## 10. Conditioning

10.1 The recommended pre-test condition is effective moisture equilibrium at a specific relative humidity as established

by Test Method D5229/D5229M; however, if the test requestor does not explicitly specify a pre-test conditioning environment, no conditioning is required and the test specimens may be tested as prepared.

10.2 The pre-test specimen conditioning process, to include specified environmental exposure levels and resulting moisture content, shall be reported with the test data.

NOTE 3—The term moisture, as used in Test Method D5229/D5229M, includes not only the vapor of a liquid and its condensate, but the liquid itself in large quantities, as for immersion.

10.3 If no explicit conditioning process is performed the specimen conditioning process shall be reported as “unconditioned” and the moisture content as “unknown.”

## 11. Procedure

### 11.1 Parameters to Be Specified Before Test:

11.1.1 The specimen sampling method, specimen geometry, and conditioning travelers (if required).

11.1.2 The properties and data reporting format desired.

NOTE 4—Determine specific material property, accuracy, and data reporting requirements prior to test for proper selection of instrumentation and data recording equipment. Estimate the specimen crush stress to aid in transducer selection, calibration of equipment, and determination of equipment settings.

11.1.3 The environmental conditioning test parameters.

11.1.4 The method of pre-crushing and target pre-crush depth, if performed.

### 11.2 General Instructions: