



Designation: ~~D6791 – 11 (Reapproved 2017)~~^{ε1} D6791 – 22

Standard Test Method for Determination of Grain Stability of Calcined Petroleum Coke¹

This standard is issued under the fixed designation D6791; the number immediately following the designation indicates the year of original adoption or, in the case of revision, the year of last revision. A number in parentheses indicates the year of last reapproval. A superscript epsilon (ϵ) indicates an editorial change since the last revision or reapproval.

^{ε1} NOTE—Units formatting was corrected editorially in February 2017.

1. Scope Scope*

1.1 This test method covers a laboratory vibration mill method for the determination of the grain stability of calcined petroleum coke for the manufacture of carbon products used in the smelting of aluminum. Calcined petroleum coke with poor mechanical strength may become degraded during mixing. Poor grain stability will affect the grain size and may result in poor quality of baked blocks.

1.2 The values stated in SI units are to be regarded as standard. No other units of measurement are included in this standard.

1.3 *This standard does not purport to address all of the safety concerns, if any, associated with its use. It is the responsibility of the user of this standard to establish appropriate safety, health, and environmental practices and determine the applicability of regulatory limitations prior to use.*

1.4 *This international standard was developed in accordance with internationally recognized principles on standardization established in the Decision on Principles for the Development of International Standards, Guides and Recommendations issued by the World Trade Organization Technical Barriers to Trade (TBT) Committee.*

2. Referenced Documents

2.1 ASTM Standards:²

[D346 Practice for Collection and Preparation of Coke Samples for Laboratory Analysis](#)

[D2013 Practice for Preparing Coal Samples for Analysis](#)

[D2234/D2234M Practice for Collection of a Gross Sample of Coal](#)

[D6969 Practice for Preparation of Calcined Petroleum Coke Samples for Analysis](#)

[D6970 Practice for Collection of Calcined Petroleum Coke Samples for Analysis](#)

[E11 Specification for Woven Wire Test Sieve Cloth and Test Sieves](#)

2.2 ISO Standard:³

[ISO 6375 Carbonaceous Materials for the Production of Aluminum—Coke for Electrodes—Sampling](#)

3. Terminology

3.1 Definitions:

¹ This test method is under the jurisdiction of ASTM Committee D02 on Petroleum Products, Liquid Fuels, and Lubricants and is the direct responsibility of Subcommittee D02.05 on Properties of Fuels, Petroleum Coke and Carbon Material.

Current edition approved Jan. 1, 2017; May 1, 2022. Published February 2017; May 2022. Originally approved in 2002. Last previous edition approved in 2014 as ~~D6791 – 11~~ D6791 – 11 (2017)^{ε1}. DOI: ~~10.1520/D6791-11R17E01~~ 10.1520/D6791-22.

² For referenced ASTM standards, visit the ASTM website, www.astm.org, or contact ASTM Customer Service at service@astm.org. For *Annual Book of ASTM Standards* volume information, refer to the standard's Document Summary page on the ASTM website.

³ Available from American National Standards Institute (ANSI), 25 W. 43rd St., 4th Floor, New York, NY 10036, <http://www.ansi.org>.

*A Summary of Changes section appears at the end of this standard

3.1.1 *calcined petroleum coke, n*—petroleum coke that has been thermally treated to drive off the volatile matter and to develop crystalline structure.

3.1.2 *petroleum coke, n*—solid, carbonaceous residue produced by thermal decomposition of heavy petroleum fractions, or cracked stocks, or both.

4. Summary of Test Method

4.1 A representative sample of calcined petroleum coke is dried and screened to a 4 mm to 8 mm fraction. The resultant sample is weighed so that two separate portions of $100.0\text{ g} \pm 0.5\text{ g}$ mass are obtained. The samples are placed into the laboratory mill and ground for a specified period of time. After grinding the sample is screened and the mass of the ~~+4 mm~~ 4 mm material is determined. The grain stability is the percent of the original material remaining on the ~~+4 mm~~ 4 mm sieve.

5. Significance and Use

5.1 The grain stability of calcined petroleum coke determines the resistance to breakdown of ~~+4 mm~~ 4 mm particles used in the manufacture of carbon anodes for use in the reduction process of aluminum.

5.2 Calcined petroleum cokes have to be relatively easy to grind for fines production but strong enough to withstand forming pressures and thermal stresses occurring when the anodes are used in the reduction process.

6. Interferences

6.1 No material normally applied to the calcined petroleum coke is found to cause analytical interference with this procedure.

7. Apparatus

7.1 *Analytical Balance*, accurate to $\pm 0.1\text{ g} \pm 0.1\text{ g}$.

7.2 *Rifflers*, with hoppers and closures.

7.3 *Wire Sieves*, 8 mm ($\frac{5}{16}$ in.) and 4 mm (5 mesh), meeting Specification **E11**.

7.4 *Laboratory Vibration Mill*⁴, having two grinding vessels, each filled with 1 kg of clean, hard steel balls, diameter $10\text{ mm} \pm 0.4\text{ mm}$. The main features of the mill are shown in **Figs. 1-5**.

7.4.1 The mill and drive motor are mounted on a common base plate. The grinding vessels are installed in the body of the mill, which is supported by four soft, flat springs. The spring suspension system is designed to allow the machine to be operated without any fastenings or anchorage. The grinding vessels are secured by adjustable straps which have a quick-release catch. The oscillator is supported on a bearing, fitted to the body of the mill, and is driven by the motor by way of a special clutch and a hollow flexible shaft.

7.4.2 The peak-to-peak amplitude of the vibration shall be $4\text{ mm} \pm 0.5\text{ mm}$. A reference disc is fitted to the front of the machine to measure the amplitude of vibration.

7.4.3 The motor shall be capable of 1450 r/min to 1470 r/min. The motor may be set up for 50 Hz rather than 60 Hz power. A tachometer can be used to verify that the motor is the specified r/min. The motor speed can be regulated with a dc speed controller to adjust it to the specified r/min. The bearing housing is rigidly connected to the bearings. The shaft rotates inside the bearings with two steel imbalance discs attached and is connected to the motor by way of the clutch. The imbalance discs are shown in **Fig. 4**.

⁴ The sole source of supply of the vibration mill is Siebtechnik GmbH, P.O. Box/Postfach 10 17 51, D-25417 MUELHEIM an der RUHR, Germany. If you are aware of alternative suppliers, please provide this information to ASTM International Headquarters. Your comments will receive careful consideration at a meeting of the responsible technical committee,¹ which you may attend.

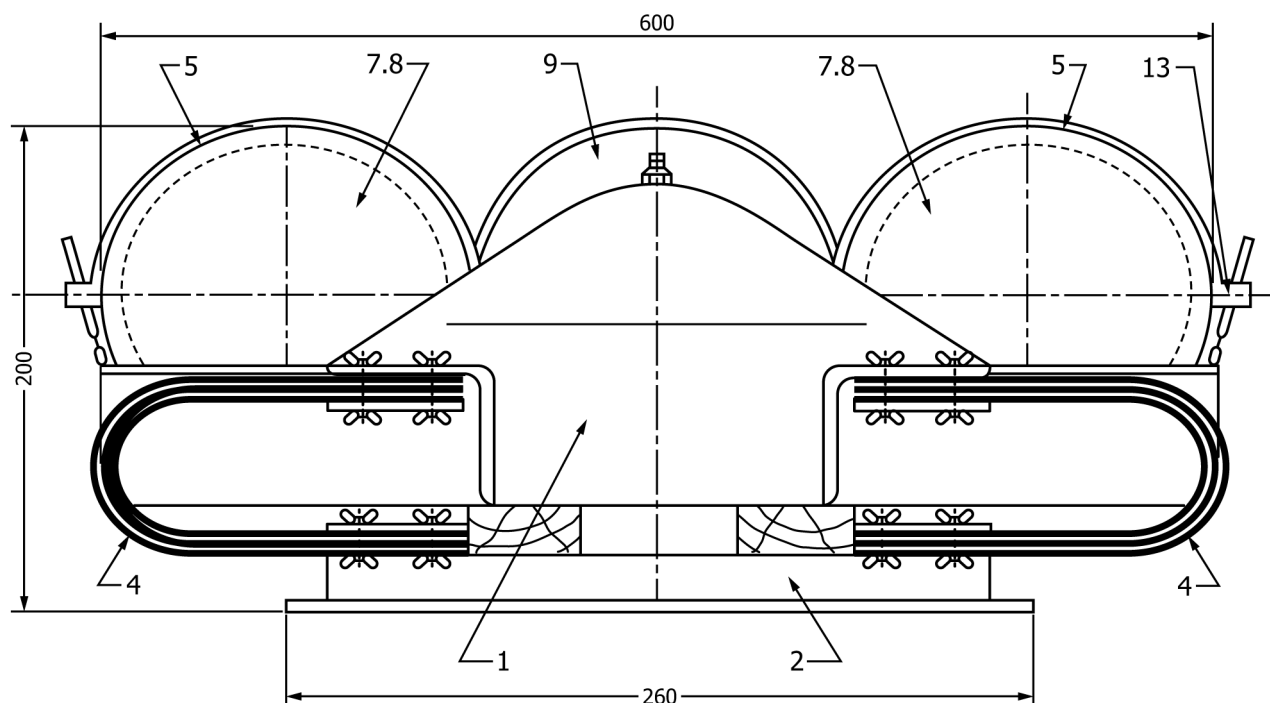

- 1 = mill
- 2 = common base plate
- 4 = flat springs
- 5 = adjustable straps
- 7,8 = grinding vessels
- 9 = motor
- 13 = quick release catch

NOTE 1—All dimensions are in millimetres.

iTeh Standards
(<https://standards.itih.ai>)
Document Preview

ASTM D6791-22

<https://standards.itih.ai/catalog/standards/astm-d6791-22> FIG. 1 Laboratory Vibration Mill (Front View)

7.4.4 The imbalance discs rotate eccentrically and the entire oscillating mass follows with a phase lag of 180°, supported by the springs. Each grinding vessel (see Fig. 5) has a total volume of 1 L and an effective volume of 0.3 L. It is closed by a lid with a rubber sealing ring. The lid is held in place by a clamp fitted with a wing nut.

7.4.5 The electric motor is linked to a timer switch having a precision of $\pm 2 \text{ s} \pm 2 \text{ s}$.

8. Sample Preparation

8.1 For recommended practice for obtaining, handling, and preparing coke samples, refer to Practices D346, D2013, D2234/D2234M, D6969, D6970, and ISO 6375. Do not precrush the sample. Sieve the sample to collect 200 g of coke of grain size between 4 mm and 8 mm.

9. Procedure

9.1 Carefully place 1 kg of the steel balls and 100 g \pm 0.5 g of the 4 mm to 8 mm fraction of the sieved test sample in each grinding vessel and close the lid. Record the weight to the nearest 0.1 g. Attach the vessels to the vibration mill.

9.2 Turn the mill on and grind the sample for 3.5 min \pm 2 s as measured by the timer switch.

9.3 Carefully empty the contents of one vessel on to an 8 mm sieve, placed on top of a 4 mm sieve. Screen by hand, using

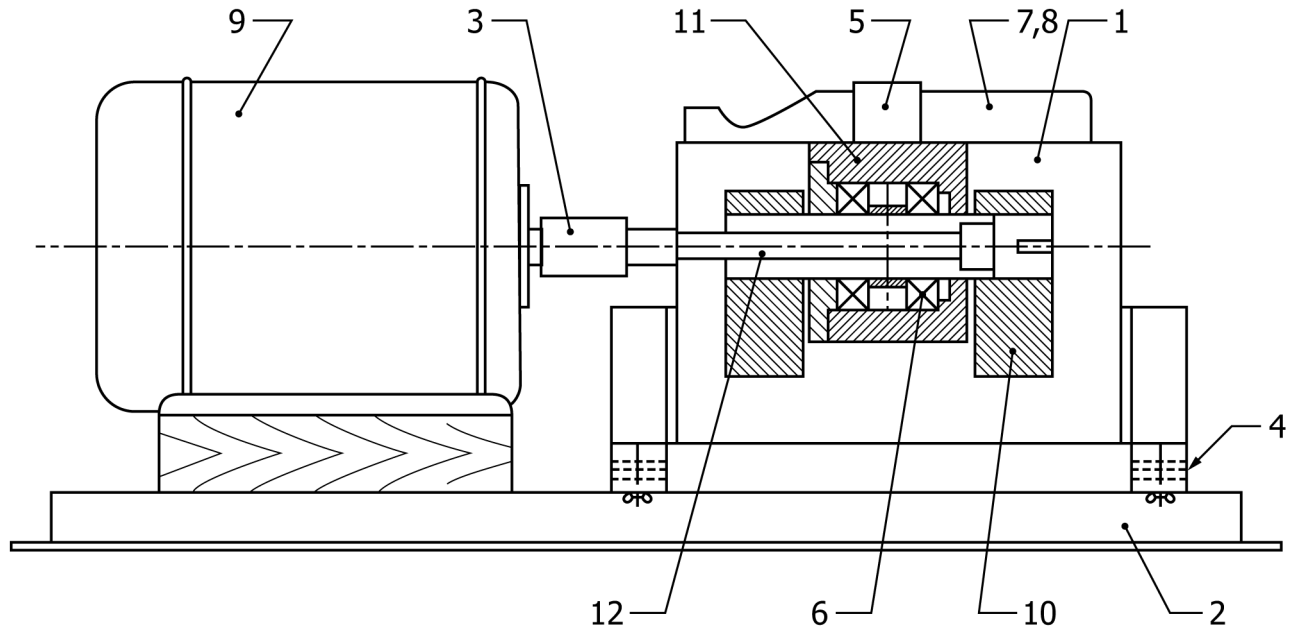

- 2 = common baseplate
- 3 = special clutch
- 4 = flatsprings
- 5 = adjustable straps
- 6 = bearing
- 7,8 = grinding vessels
- 9 = motor
- 10 = discs
- 11 = bearing housing
- 12 = shaft

iTeh Standards
 (https://standards.itih.ai)
 Document Preview

ASTM D6791-22
FIG. 2 Laboratory Vibration Mill (Side View)

<https://standards.itih.ai/catalog/standards/sist/d809d27c-302b-45ed-b644-3de0e83bf42c/astm-d6791-22>

approximately 60 horizontal movements in about half a minute. The steel balls will remain on the 8 mm sieve, and part of the granular material will remain on the 4 mm sieve.

9.4 Weigh the portion of granular material that remains on the 4 mm sieve to the nearest 0.01 g and record as vessel 1, m_3 .

9.5 Repeat with the contents of the other vessel and record as vessel 2, m_4 .

10. Calculation

10.1 The grain stability (GS) of the calcined petroleum coke, expressed in percent, is given by the equation:

$$GS = \frac{GS_1 + GS_2}{2} = \frac{1}{2} \left[\frac{m_3}{m_1} + \frac{m_4}{m_2} \right] \times 100 \quad (1)$$

where:

- GS_1 = grain stability for vessel 1 in %,
- GS_2 = grain stability for vessel 2 in %,
- m_1 = mass of test sample placed in vessel 1, g,
- m_2 = mass of test sample placed in vessel 2, g,
- m_3 = mass of test sample from vessel 1 retained on the 4 mm sieve, g, and
- m_4 = mass of test sample from vessel 2 retained on the 4 mm sieve, g.