



Designation: F3084 – 22

Standard Consumer Safety Specification for Infant and Infant/Toddler Rockers¹

This standard is issued under the fixed designation F3084; the number immediately following the designation indicates the year of original adoption or, in the case of revision, the year of last revision. A number in parentheses indicates the year of last reapproval. A superscript epsilon (ϵ) indicates an editorial change since the last revision or reapproval.

INTRODUCTION

This consumer safety specification addresses incidents associated with infant and infant/toddler rockers identified by the U.S. Consumer Product Safety Commission (CPSC).

In response to incident data compiled by the CPSC, this specification attempts to minimize the following hazards: disassembly/collapse, stability, and falls from elevated surfaces.

This specification is intended to cover normal use and reasonably foreseeable misuse or abuse of the product(s).

This specification is written within the current state-of-the-art of product technology and will be updated whenever substantive information becomes available that necessitates additional requirements or justifies the revision of existing requirements.

1. Scope

1.1 This consumer safety specification covers establishment of requirements, test methods, and marking requirements to promote safe use of the rocker by an occupant and a caregiver.

1.2 This specification does not cover rockers intended for toddler only use without a restraint system, hand-held infant carriers, or sleep products that have the ability to rock or have a rocking mode.

1.3 This consumer safety specification is intended to minimize the risk of injury to an occupant resulting from normal use and reasonably foreseeable misuse or abuse of an infant or infant/toddler rocker.

1.4 No rocker produced after the approval date of this consumer safety specification shall, either by label or other means, indicate compliance with this specification unless it conforms to all requirements contained herein.

1.5 This consumer safety specification is not intended to address incidents and injuries resulting from the interaction of other persons with the occupant in the product or the incidents resulting from abuse or misuse by other children.

1.6 The values stated in inch-pound units are to be regarded as standard. The values given in parentheses are mathematical conversions to SI units that are provided for information only and are not considered standard.

¹ This consumer safety specification is under the jurisdiction of ASTM Committee F15 on Consumer Products and is the direct responsibility of Subcommittee F15.21 on Infant Carriers, Bouncers and Baby Swings.

Current edition approved May 1, 2022. Published May 2022. Originally approved in 2014. Last previous edition approved in 2020 as F3084 – 20. DOI: 10.1520/F3084-22.

1.7 The following precautionary caveat pertains only to the test methods portion, Section 7, of this specification: *This standard does not purport to address all of the safety concerns, if any, associated with its use. It is the responsibility of the user of this standard to establish appropriate safety, health, and environmental practices and determine the applicability of regulatory limitations prior to use.*

1.8 *This international standard was developed in accordance with internationally recognized principles on standardization established in the Decision on Principles for the Development of International Standards, Guides and Recommendations issued by the World Trade Organization Technical Barriers to Trade (TBT) Committee.*

2. Referenced Documents

2.1 ASTM Standards:²

- D3359 Test Methods for Rating Adhesion by Tape Test
- F963 Consumer Safety Specification for Toy Safety
- F2050 Consumer Safety Specification for Hand-Held Infant Carriers
- F2167 Consumer Safety Specification for Infant Bouncer Seats
- F2194 Consumer Safety Specification for Bassinets and Cradles

2.2 EN Standards:

- EN 12790:2009 Child use and care articles—Reclined cradles

² For referenced ASTM standards, visit the ASTM website, www.astm.org, or contact ASTM Customer Service at service@astm.org. For *Annual Book of ASTM Standards* volume information, refer to the standard's Document Summary page on the ASTM website.

2.3 Federal Regulations:

- 16 CFR 1303 Ban of Lead-Containing Paint and Certain Consumer Products Bearing Lead-Containing Paint
- 16 CFR 1500.48 Technical Requirements for Determining a Sharp Point in Toys or Other Articles Intended for Use by Children Under Eight Years of Age
- 16 CFR 1500.49 Technical Requirements for Determining a Sharp Metal or Glass Edge in Toys or Other Articles Intended for Use by Children Under Eight Years of Age
- 16 CFR 1500.50-.52 Test Methods for Simulating Use and Abuse of Toys and Other Articles Intended for Use by Children
- 16 CFR 1501 Method for Identifying Toys and Other Articles Intended for Use by Children Under Three Years of Age Which Present Choking, Aspiration or Ingestion Hazards Because of Small Parts

2.4 ANSI Standards:³

- ANSI Z535.1 Safety Colors
- ANSI Z535.4 Product Safety Signs and Labels
- ANSI Z535.6 Product Safety Information in Product Manuals, Instructions, and Other Collateral Materials

2.5 Other References:

- 49 CFR Part 572.25 NHTSA Subpart D—6 Month-Old CAMI Infant Dummy, Mark II, Fig. 1
- 49 CFR Part 572.90 and 572.91 NHTSA Subpart K—CAMI Newborn Infant Dummy, Fig. 2

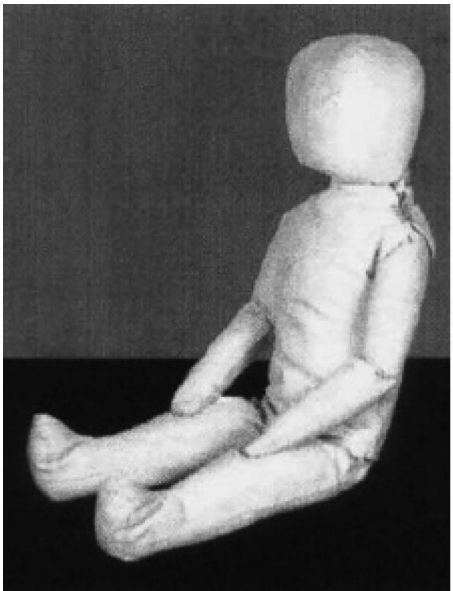

FIG. 2 CAMI Newborn Infant Dummy

3. Terminology

3.1 Definitions:

3.1.1 *conspicuous, adj*—visible, when the product is in a manufacturer’s recommended use position, to a person sitting near the product at any one position around the product but is not necessarily visible from all positions.

³ Available from American National Standards Institute (ANSI), 25 W. 43rd St., 4th Floor, New York, NY 10036, <http://www.ansi.org>.

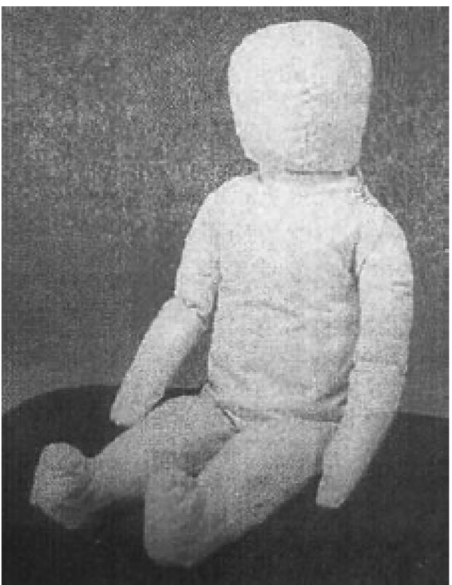

FIG. 1 CAMI Infant Dummy, Mark II

3.1.2 *double-action release system, n*—a mechanism requiring either two consecutive actions, the first of which must be maintained while the second is carried out, or two separate and independent simultaneous actions to fully release.

3.1.3 *dynamic load, n*—application of an impulsive force through free fall of a weight.

3.1.4 *fabric, n*—any woven, knit, coated, laminated, extruded, or calendered flexible material that is intended to be sewn, welded, heat sealed, or glued together as an assembly.

3.1.5 *grasping point on toy bar, n*—five-inch wide section of the toy bar centered at the mid-point of the toy bar if the toy bar is attached at two points on the frame.

3.1.5.1 *Discussion*—If the toy bar has a single attachment point, the 5-in. dimension is either centered at the mid-point of the product or as close to the mid-point as possible, should the toy bar not extend far enough beyond the mid-point to achieve this. The load should be evenly distributed over this 5-in. dimension.

3.1.6 *infant rocker, n*—a freestanding product intended to support an occupant who has not developed the ability to sit up unassisted (approximately 0 to 6 months of age) in a seated, reclined position greater than 10° and to facilitate rocking by the occupant with the aid of the caregiver or by other means.

3.1.7 *infant/toddler rocker, n*—a freestanding product intended to support an occupant in a seated, reclined position greater than 10° and to facilitate rocking by the occupant with the aid of the caregiver or by other means until the occupant is approximately 2½ years.

3.1.8 *kickstand, n*—a device intended by the manufacturer to prevent any rocking motion.

3.1.8.1 *Discussion*—A kickstand may include hinged legs, feet or other mechanical stops.

3.1.9 *manufacturer’s recommended use position(s), n*—any position that is presented as a normal, allowable, or acceptable

configuration for the use of the product by the manufacturer in any descriptive or instructional literature.

3.1.9.1 *Discussion*—This specifically excludes positions that the manufacturer shows in a like manner in its literature to be unacceptable, unsafe, or not recommended.

3.1.10 *non-paper label, n*—any label material (such as plastic or metal) that either will not tear without the aid of tools or tears leaving a sharply defined edge.

3.1.11 *occupant, n*—that individual who is in a product that is set up in one of the manufacturer’s recommended use positions.

3.1.12 *paper label, n*—any label material that tears without the aid of tools and leaves a fibrous edge.

3.1.13 *protective component, n*—any component used for protection from sharp edges, points, or entrapment of fingers or toes.

3.1.13.1 *Discussion*—Examples of protective components include caps, sleeves and plugs.

3.1.14 *seam, n*—means of joining fabric components, such as sewing, welding, heat sealing, or gluing.

3.1.15 *seat bight, n*—the intersection of the seat back surface with the seat bottom surface (see Figs. 3 and 4).

3.1.16 *static load, n*—vertically downward load applied by weights or other means.

3.1.17 *toy bars, n*—any bar or mobile connected to the frame of the product in any location with one or more attachment points typically used to suspend toys over the occupant.

3.1.17.1 *Discussion*—Canopies, fixed and rotating, are not considered a toy bar regardless of whether they allow for the attachment of toys.

4. Calibration and Standardization

4.1 All testing shall be conducted on a concrete floor, which may be covered with 1/8-in. (3-mm) thick vinyl flooring cover, unless the test instructs differently.

4.2 The product shall be completely assembled, unless otherwise noted, in accordance with the manufacturer’s instructions.

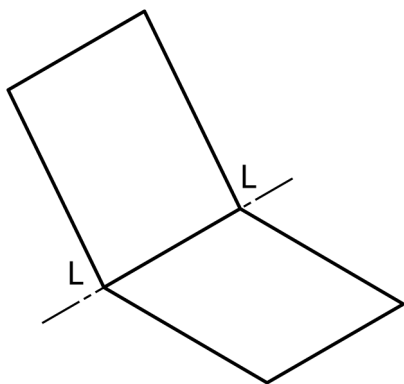

FIG. 3 Typical Seat Bight (LL—Seat Bight)

4.3 No testing shall be conducted within 48 h of manufacturing.

4.4 The product to be tested shall be removed from any shipping materials or packaging and stored in a room with an ambient temperature of 73 °F ± 9 °F (23 °C ± 5 °C) for at least one hour prior to testing. Testing shall then be conducted within this temperature range.

4.5 All testing required by this specification shall be conducted on the same product.

5. General Requirements

5.1 *Hazardous Sharp Points and Edges*—There shall be no hazardous points or edges as defined by 16 CFR 1500.48 and 16 CFR 1500.49 before and after testing to this consumer safety specification.

5.2 *Small Parts*—There shall be no small parts as defined by 16 CFR 1501 before testing or liberated as a result of testing to this specification.

5.3 *Lead*—All paints and surface coatings shall comply with 16 CFR 1303.

5.4 *Wood Parts*—Prior to testing, any exposed wood parts shall be smooth and free from splinters.

5.5 *Latching or Locking Mechanisms*—If the rocker is designed with a latching or locking device that prevents unintentional folding, the rocker shall meet either 5.5.1 or 5.5.2. The latching or locking device shall remain engaged and operative after all testing.

5.5.1 The latching or locking device shall be a double-action release system.

5.5.2 The product’s latching or locking device shall not release and remain operative when tested in accordance with 7.2.

5.6 *Scissoring, Shearing, and Pinching*—The product, when in any manufacturer’s recommended use position(s), shall be designed and constructed so as to prevent injury to the occupant from any scissoring, shearing, or pinching when members or components rotate about a common axis or fastening point, slide, pivot, fold, or otherwise move relative to one another. Scissoring, shearing, or pinching that may cause injury exists when the edges of the rigid parts admit a probe greater than 0.210 in. (5.33 mm) and less than 0.375 in. (9.53 mm) in diameter at any accessible point throughout the range of motion of such parts.

5.7 *Openings*—Holes or slots that extend entirely through a wall section of any rigid material less than 0.375-in. (9.53-mm) thick and admit a 0.210-in. (5.33-mm) diameter rod shall also admit a 0.375-in. (9.53-mm) diameter rod. Holes or slots that are between 0.210-in. (5.33-mm) and 0.375-in. (9.53-mm) and have a wall thickness less than 0.375-in. (9.53-mm), but are limited in depth to 0.375-in. (9.53-mm) maximum by another rigid surface shall be permissible (see Fig. 5). The product shall be evaluated in all manufacturer’s recommended use positions.

5.8 *Exposed Coil Springs*—Any exposed coil spring that is accessible to the occupant, having or capable of generating a space between coils of 0.210 in. (5.33 mm) or greater during

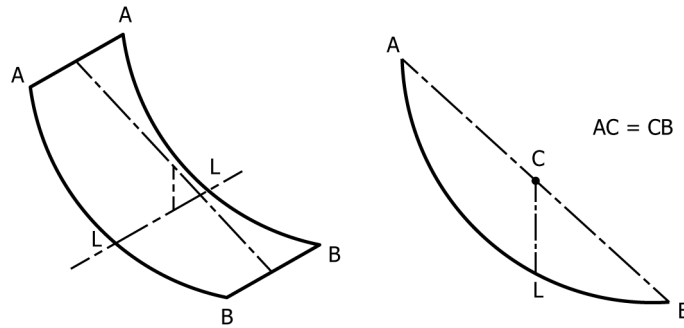

FIG. 4 Hammock Type Seat Bight (LL—Seat Bight; CL—Vertical projection of C on the hammock)

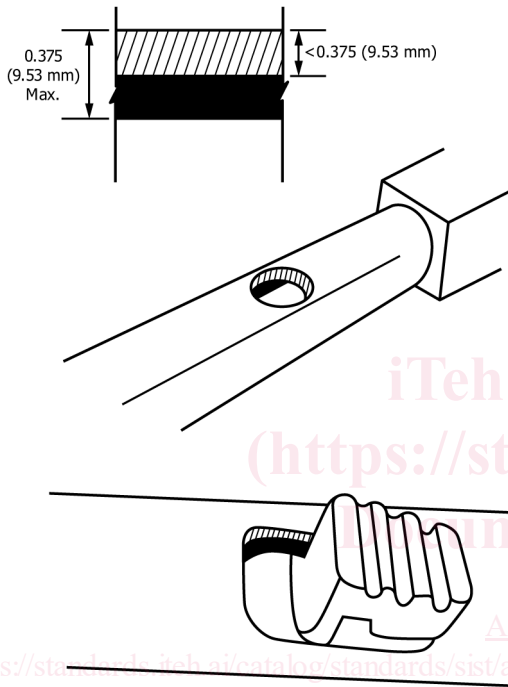

FIG. 5 Opening Example

static load testing in accordance with 7.6.2 shall be covered or otherwise designed to prevent injury from entrapment.

5.9 *Protective Components*—If a child can grasp components between the thumb and forefinger, or teeth, or if there is at least a 0.04 in. (1.0 mm) gap between the component and its adjacent parent component, such component shall not be removed when tested in accordance with 7.10. All protective components that are accessible to a child in the product or accessible to a child from any position around the product shall be evaluated.

5.10 *Permanency of Labels and Warnings:*

5.10.1 Warning labels (whether paper or non-paper) shall be permanent when tested in accordance with 7.9.1 – 7.9.3.

5.10.2 Warning statements applied directly onto the surface of the product by hot stamping, heat transfer, printing, wood burning, etc. shall be permanent when tested in accordance with 7.9.4.

5.10.3 Non-paper labels shall not liberate small parts when tested in accordance with 7.9.5.

5.11 *Toys*—Toy accessories attached to, removable from, or sold with a rocker, as well as their means of attachment, shall comply with the applicable requirements of Standard Consumer Safety Specification for Toy Safety F963.

5.12 *Rocker Converts to Another Juvenile Product*—If the rocker can be converted into a different product for which another ASTM standard consumer safety specification exists, the product shall meet the applicable requirements of that standard when in that use mode. For example, a rocker that converts to a bassinet shall also comply with the applicable requirements of Consumer Safety Specification F2194 when in a bassinet mode.

6. Performance Requirements

6.1 *Seat Angles*—The rocker shall meet the following when tested in accordance with 7.1.

6.1.1 The angle between the seat back and the seat bottom shall be greater than or equal to 90°.

6.1.2 The angle between the seat back and the horizontal shall be greater than 10° and less than 80°.

6.2 *Restraint System:*

6.2.1 A restraint system shall be provided to secure a child in any of the manufacturer’s recommended use positions.

6.2.2 The restraint system shall include both a waist and crotch restraint, where the crotch restraint’s use is mandatory when the waist restraint is in use.

6.2.3 The anchorages for the restraint system shall not separate from their attachment points when tested in accordance with 7.3.

6.3 *Stability:*

6.3.1 *Forward Stability*—The rocker shall not tip over when tested in accordance with 7.4.1.

6.3.1.1 *Forward Stability Infant/Toddler Rockers*—If the product is intended for use after the occupant can sit upright unassisted, the rocker shall not tip over when tested in accordance with 7.4.2.

6.3.2 *Sideward and Rearward Stability*—The rocker shall not tip over when tested in accordance with 7.4.3.

6.4 *Static Slip Resistance*—The rocker shall not slip more than 1/8 in. (3 mm) when tested in accordance with 7.5 in the non-rocking position. If the item has only a rocking mode, this requirement does not apply.

6.5 *Structural Integrity*—At test conclusion, there shall be no failure of seams, breakage of materials, or changes of

adjustments that could cause the product not to fully support the child or create a hazardous condition as defined in Section 5.

6.5.1 *Dynamic Load*—The rocker shall not create a hazardous condition as defined in Section 5 when tested in accordance with 7.6.1.

6.5.2 *Static Load*—The rocker shall not create a hazardous condition as defined in Section 5 when tested in accordance with 7.6.2.

6.6 *Disassembly/Collapse*—The rocker shall not disassemble or collapse when tested in accordance with 7.7.

6.7 *Toy Bar Attachment Integrity:*

6.7.1 *Toy Bar Attachment Release*—Toy bars must meet the requirements in 6.7.1.1 or 6.7.1.2 or 6.7.1.3:

6.7.1.1 The toy bar must not completely release from the rocker from any attachment point when tested to 7.8.1.2 and 7.8.2.

6.7.1.2 The toy bar must completely release before the entire rocker lifts off the test surface when tested to 7.8.1.3.

6.7.1.3 For toy bars that contain a single attachment point, the furthestmost point at the free end of the toy bar must move more than 2 in. (5.1 cm) from its original resting position while attempting to lift the rocker off the test surface when tested to 7.8.1.3.

7. Test Methods

NOTE 1—The tests described in 7.1 through 7.8 are to be performed in the order specified without refurbishing or repositioning of adjustments, if any.

7.1 *Seat Angles Test:*

7.1.1 *Angle between Seat Back and Seat Bottom:*

7.1.1.1 For rockers with an adjustable seat back, adjust the seat back into the most upright position.

7.1.1.2 Place the rocker in the most upright manufacturer’s recommended use position. This position could be with or without the kickstand up.

7.1.1.3 Position the segments of the restraint system to limit interaction with the hinged weight gauge–infant (Fig. 6) when placed in the seat.

7.1.1.4 Place the hinged weight gauge–infant in the rocker with the hinged edge into the seat bight.

7.1.1.5 Place the inclinometer on the floor and zero the reading.

7.1.1.6 Measure the angle between the seat back and the seat bottom (Fig. 7).

7.1.2 *Angle between Seat Back and Horizontal:*

7.1.2.1 For rockers with an adjustable seat back, adjust the seat back into the most reclined position.

7.1.2.2 Place the rocker in the most reclined manufacturer’s recommended use position. This position could be with or without the kickstand up.

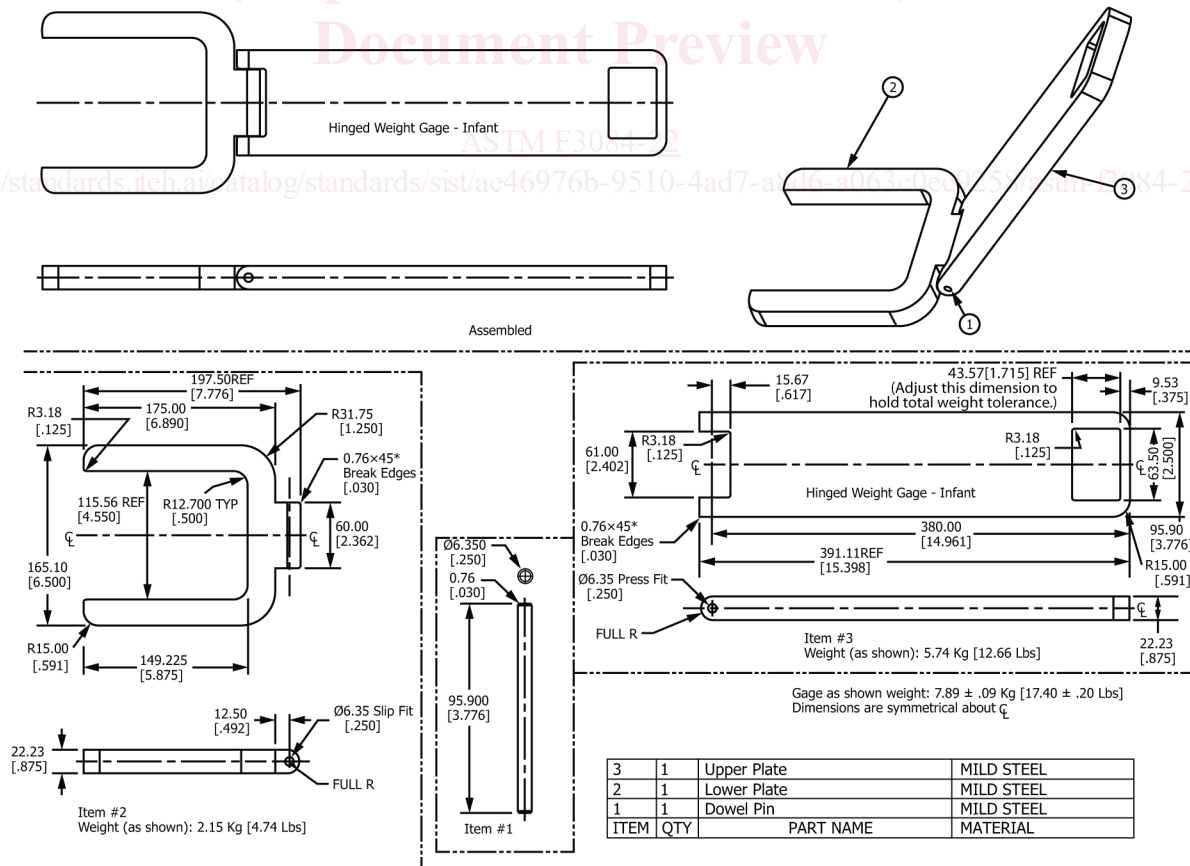

FIG. 6 Hinged Weight Gauge—Infant

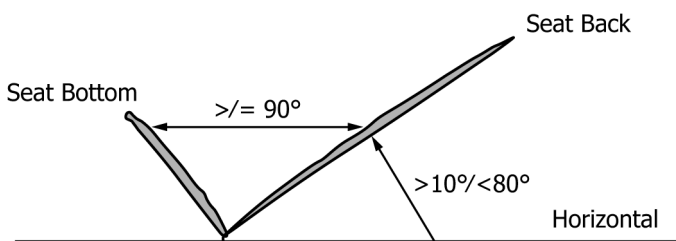

FIG. 7 Seat Angle Measurements

7.1.2.3 Position the segments of the restraint system to limit interaction with the hinged weight gauge-infant (Fig. 6) when placed in the seat.

7.1.2.4 Place the hinged weight gauge-infant in the rocker with the hinged edge into the seat bight.

7.1.2.5 Place the inclinometer on the floor and zero the reading.

7.1.2.6 Measure the angle between the seat back and the horizontal (Fig. 7).

7.2 Single-action Release Mechanisms:

7.2.1 Set up the product in the manufacturer's recommended use position.

7.2.2 If the mechanism requires a pull or push action, gradually apply a force of 10 lbf (45 N) to the latching or locking mechanism in the direction tending to release it.

7.2.3 If the mechanism requires a twist or turn action, gradually apply a torque of 4 lbf-in. (0.5 N-m) to the latching or locking mechanism in the direction tending to release it.

7.3 Restraint System:

7.3.1 Secure the rocker so that it cannot move vertically or horizontally.

7.3.2 Apply a force of 45 lbf (200 N) to a single attachment point of the restraint system in the normal use direction(s) that stress would be applied to the attachment. Gradually apply the force within a period of 5 s and maintain for an additional 10 s.

7.3.3 Repeat 7.3.2 for each attachment point of the restraint system and fastening device.

7.4 Stability:

7.4.1 Forward Stability:

7.4.1.1 Test Equipment:

(1) Stability Test Fixture:

(a) The forward stability test fixture is to be constructed of 3/4-in. (19-mm) plywood or the equivalent of such product.

(b) The fixture shall be constructed according to Fig. 8.

(2) The test surface shall be an impregnated high pressure laminate of unspecified color with a smooth matte finish.

7.4.1.2 Set up the rocker in the manufacturer's use position with the kickstand up to allow rocking if applicable. For rockers with an adjustable seat back, adjust the seat into the most upright manufacturer's recommended use position.

7.4.1.3 Establish the restraint system adjustment position by placing the CAMI Infant Dummy, Mark II (Fig. 1) in the rocker, fastening and adjusting the restraint system in accordance with the manufacturer's instructions, and then remove the dummy.

Note: All dimensions are in inches. All dimensions are +/- .03

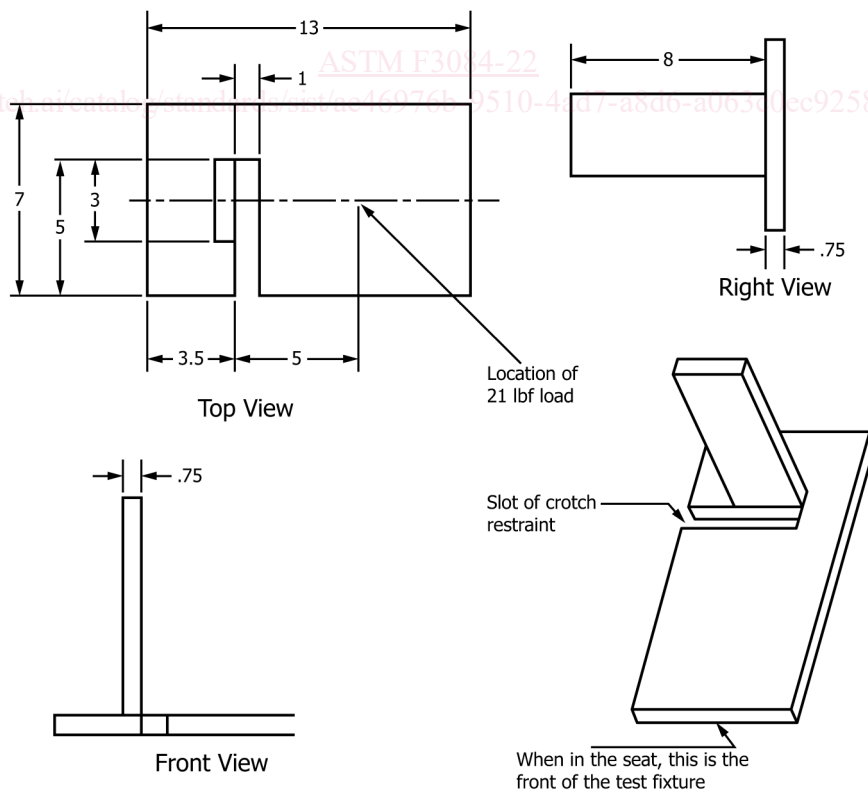

FIG. 8 Forward Stability Test Fixture

7.4.1.4 Insert the forward stability test fixture (Fig. 8) into the rocker with the crotch belt positioned in the slot for the crotch restraint, and secure the waist restraints to the crotch restraint without adjusting the restraint from the position established in 7.4.1.3.

7.4.1.5 Pull forward on the forward stability test fixture to remove any slack in the crotch restraint.

7.4.1.6 Apply a static load of 21 lbf (93 N) vertically downward on the stability test fixture in the location designated in Fig. 8 (5-in. (130-mm) in front of the crotch post) within a period of 5 s and maintain for an additional 60 s (Fig. 9). If the stability test fixture touches the test surface and prevents the product from tipping over, retest the product near the edge of an elevated test surface to allow the product to tip.

7.4.1.7 Repeat 7.4.1.6 with the kickstand deployed to prevent rocking if applicable.

7.4.2 *Forward Stability for Infant/Toddler Rockers:*

7.4.2.1 *Test Equipment:*

(1) Stability Test Fixture for Infant/Toddler Rockers constructed according to Fig. 10.

(2) Test Surface

(a) The test surface shall be an impregnated high pressure laminate of unspecified color with a smooth matte finish.

(b) The laminate should be mounted on a flat surface, with a thickness no less than 3/4 in. (19 mm), in accordance with the laminate manufacturer's instructions.

(c) The test surface shall be fixed at an angle of 18° from horizontal.

(d) A stop or equivalent device mounted parallel to the lower edge of the surface and parallel to the floor so as to prevent the seat from sliding, but not prevent it from tipping.

7.4.2.2 Set up the rocker in the manufacturer's use position where the seat is most likely to create forward instability.

7.4.2.3 Place the stability test fixture for infant/toddler rockers (Fig. 10) in the seat with the back edge of the gage aligned with the seat bight. Position the crotch belt in the fixture slot for the crotch restraint, and secure the waist restraints to the crotch restraint. If the product has shoulder straps as part of the restraint system, secure and tighten around the test fixture.

7.4.2.4 Tighten the restraint system in such a manner that you can comfortably slide your little finger between the strap

and the test fixture cylinder, while maintaining alignment of the gage back edge and the seat bight.

7.4.2.5 Position the product on the inclined surface facing down the incline, with the lower most frame member(s) in contact with the stop.

7.4.2.6 While holding the product to prevent product from tipping forward, gradually apply a pull force of 10 lbf (44 N) parallel to the test fixture (Fig. 11) on the waist restraint near the center of the fixture to induce any potential forward displacement allowed by the seat or restraint. Gradually apply the force within 5 s and maintain for an additional 10 s.

7.4.2.7 Release the product to allow for any tipping.

7.4.3 *Sideward and Rearward Stability:*

7.4.3.1 *Test Equipment:*

(1) CAMI Infant Dummy, Mark II (Fig. 1)

(2) The test surface shall be an impregnated high pressure laminate of unspecified color with a smooth matte finish.

7.4.3.2 Set up the rocker in the manufacturer's use position with the kickstand up to allow rocking if applicable. For rockers with an adjustable seat back, adjust the seat into the most upright recommended manufacturer's use position.

7.4.3.3 Place a CAMI Infant Dummy, Mark II (see Fig. 1) in the rocker with the restraint system fastened in accordance with the manufacturer's instructions.

7.4.3.4 Position the rocker in the most unfavorable sideward or rearward position on a test surface inclined at 20°. The most unfavorable position could be a position in between the true sideward and rearward positions. If necessary, prevent the product from sliding but do not prevent it from tipping.

7.4.3.5 Maintain for 1 min.

7.4.3.6 Repeat 7.4.3.4 and 7.4.3.5 with the kickstand deployed to prevent rocking if applicable.

7.4.3.7 For rockers with an adjustable seat back, adjust the seat into the most reclined recommended manufacturer's use position and repeat 7.4.3.3 through 7.4.3.6.

7.5 *Static Slip Resistance:*

7.5.1 *Test Equipment:*

7.5.1.1 CAMI Newborn Infant Dummy (Fig. 2).

7.5.1.2 *Test Surface:*

(1) The test surface shall be an impregnated high pressure laminate of unspecified color with a smooth matte finish.

(2) The laminate should be mounted on a flat surface, with a thickness no less than 3/4 in. (19 mm), in accordance with the laminate manufacturer's instructions.

(3) The test surface shall be fixed at an angle of 10° from horizontal.

7.5.2 *Test Preparation:*

7.5.2.1 *Test Surface:*

(1) Clean the test surface with a damp cloth. Any products that will interfere with the performance of the laminate are unacceptable, for example, solvents or cleaners that leave residue or alter the surface finish.

(2) Precautions should be taken to prevent the contamination of the testing surface. Graduation or pencil marks are unacceptable unless located in a position that never interferes with the performance of the test product (that is, along the edge of the surface).



FIG. 9 Forward Stability Test