



Designation: ~~F2088 – 21~~ F2088 – 22

## Standard Consumer Safety Specification for Infant and Cradle Swings<sup>1</sup>

This standard is issued under the fixed designation F2088; the number immediately following the designation indicates the year of original adoption or, in the case of revision, the year of last revision. A number in parentheses indicates the year of last reapproval. A superscript epsilon ( $\epsilon$ ) indicates an editorial change since the last revision or reapproval.

### INTRODUCTION

This consumer safety specification addresses incidents associated with swings intended for infants identified by the U.S. Consumer Product Safety Commission (CPSC).

In response to incident data compiled by the CPSC, this specification attempts to minimize the following hazards: (1) swings tipping over or collapsing, (2) structural failures, and (3) entanglement in the restraints or entrapment in leg holes.

This specification is intended to cover normal use and reasonably foreseeable misuse or abuse of swings.

This specification is written within the current state-of-the-art of swing technology and will be updated whenever substantive information becomes available that necessitates additional requirements or justifies the revision of existing requirements.

### 1. Scope

1.1 This consumer safety specification establishes safety performance requirements, test methods, and labeling requirements to minimize the hazards to infants presented by swings as identified in the introduction.

1.2 This consumer safety specification is intended to minimize the risk of injuries to infants resulting from normal use and reasonably foreseeable misuse or abuse of swings. It is not intended to address all incidents and injuries resulting from the interaction of other persons with the infant in the swing.

1.3 This consumer safety specification covers products with a powered mechanism used for the purpose of providing a swinging or gliding seat in any direction relative to the frame (that is, front to back, side to side, arc, etc.) for an infant. The powered mechanism can be through batteries, AC adapter, wind-up mechanism, or other means. This specification does not cover products that are intended to provide sleeping accommodations for the occupant.

1.4 No swing produced after the approval date of this consumer safety specification shall, either by label or other means, indicate compliance with this specification unless it conforms to all requirements contained herein.

1.5 The values stated in inch-pound units are to be regarded as standard. The values given in parentheses are mathematical conversions to SI units that are provided for information only and are not considered standard.

<sup>1</sup> This consumer safety specification is under the jurisdiction of ASTM Committee F15 on Consumer Products and is the direct responsibility of Subcommittee F15.21 on Infant Carriers, Bouncers and Baby Swings.

Current edition approved ~~May 15, 2021~~ May 1, 2022. Published ~~June 2021~~ May 2022. Originally approved in 2001. Last previous edition approved in ~~2020~~ 2021 as ~~F2088 – 20~~ F2088 – 21. DOI: ~~10.1520/F2088-21~~ 10.1520/F2088-22.

1.6 The following precautionary caveat pertains only to the test methods portion, Section 7, of this specification: *This standard does not purport to address all of the safety concerns, if any, associated with its use. It is the responsibility of the user of this standard to establish appropriate safety, health, and environmental practices and determine the applicability of regulatory limitations prior to use.*

1.7 *This international standard was developed in accordance with internationally recognized principles on standardization established in the Decision on Principles for the Development of International Standards, Guides and Recommendations issued by the World Trade Organization Technical Barriers to Trade (TBT) Committee.*

## 2. Referenced Documents

### 2.1 ASTM Standards:<sup>2</sup>

D3359 Test Methods for Rating Adhesion by Tape Test

F406 Consumer Safety Specification for Non-Full-Size Baby Cribs/Play Yards

F963 Consumer Safety Specification for Toy Safety

F2194 Consumer Safety Specification for Bassinets and Cradles

### 2.2 Federal Regulations:<sup>3</sup>

16 CFR Part 1303 Ban of Lead-Containing Paint and Certain Consumer Products Bearing Lead-Containing Paint

16 CFR Part 1500 Hazardous Substances Act Regulations including sections:

1500.48—Technical Requirements for Determining a Sharp Point in Toys or Other Articles Intended for Use by Children Under Eight Years of Age

1500.49—Technical Requirements for Determining a Sharp Metal or Glass Edge in Toys or Other Articles Intended for Use by Children Under Eight Years of Age

1500.50-.51—Test Method for Simulating Use and Abuse of Toys and Other Articles Intended for Use by Children

16 CFR Part 1501 Method for Identifying Toys and Other Articles Intended for Use by Children Under Three Years of Age Which Present Choking, Aspiration, or Ingestion Hazards Because of Small Parts

29 CFR 1910.7 Definition and requirements for a nationally recognized testing laboratory

### 2.3 ANSI Standards:<sup>4</sup>

ANSI Z535.1 Safety Colors

ANSI Z535.4 Product Safety Signs and Labels

ANSI Z535.6 Product Safety Information in Product Manuals, Instructions, and Other Collateral Materials

### 2.4 Other Documents:

CAMI Infant Dummy, Mark II (see Fig. 1)<sup>5</sup>

CAMI Newborn Dummy (see Fig. 2)<sup>6</sup>

UL 1310 Standard for Class 2 Power Units<sup>7</sup>

## 3. Terminology

### 3.1 Definitions of Terms Specific to This Standard:

3.1.1 *combination swing, n*—a swing that has a cradle swing use, mode, or position and an infant swing use, mode, or position.

3.1.2 *conspicuous, adj*—visible, when the product is in all manufacturer’s recommended use position(s), to a person standing near the product at any one position around the swing but not necessarily visible from all positions.

3.1.3 *cradle swing, n*—a swing which is intended for use by an infant lying flat to swing or glide and is intended for use with infants from birth until infant begins to push up on hands and knees (approximately 5 months).

3.1.4 *dynamic load, n*—application of impulsive force through free fall of a weight.

<sup>2</sup> For referenced ASTM standards, visit the ASTM website, [www.astm.org](http://www.astm.org), or contact ASTM Customer Service at [service@astm.org](mailto:service@astm.org). For *Annual Book of ASTM Standards* volume information, refer to the standard’s Document Summary page on the ASTM website.

<sup>3</sup> Available from U.S. Government Printing Office Superintendent of Documents, 732 N. Capitol St., NW, Mail Stop: SDE, Washington, DC 20401.

<sup>4</sup> Available from American National Standards Institute (ANSI), 25 W. 43rd St., 4th Floor, New York, NY 10036, <http://www.ansi.org>.

<sup>5</sup> Department of Transportation Memorandum Report AAC-119-74-14, Revision II, Drawing No. SA-1001 by Richard Chandler, July 2, 1974. Federal Aviation Administration, Civil Aeromedical Institute, Protection and Survival Laboratory, Aeromedical Center, Oklahoma City, OK 73125.

<sup>6</sup> Drawing numbers 126-0000 through 126-0015 (sheets 1 through 3), 126-0017 through 126-0027, a parts list entitled “Parts List for CAMI Newborn Dummy”, and a construction manual entitled, “Construction of the Newborn Infant Dummy” (July 1992). Copies of the materials may be inspected at NHTSA’s Docket Section, 400 Seventh Street, SW., Room 5109, Washington, DC, or at the Office of the Federal Register, 800 North Capitol Street, NW., suite 700, Washington, DC.

<sup>7</sup> Available from Underwriters Laboratories (UL), 2600 N.W. Lake Rd., Camas, WA 98607-8542, <http://www.ul.com>.



FIG. 1 CAMI Infant Dummy, Mark II



FIG. 2 CAMI Newborn Dummy

3.1.5 *infant swing, n*—a swing that enables an infant in a seated position to swing or glide and is intended for use with infants from birth until infant attempts to climb out of the swing (approximately 9 months).

3.1.6 *manufacturer’s recommended use position, n*—any position, that is presented as a normal, allowable, or acceptable configuration for the use of the product by the manufacturer in any descriptive or instructional literature; this specifically excludes positions that the manufacturer shows in a like manner in its literature to be unacceptable, unsafe, or not recommended.

3.1.7 *non-paper label, n*—any label material (such as plastic or metal) which either will not tear without the aid of tools or tears leaving a sharply defined edge.

3.1.8 *occupant, n*—that individual who is in a product that is set up in one of the manufacturer’s recommended use positions.

3.1.9 *paper label, n*—any label material which tears without the aid of tools and leaves a fibrous edge.

3.1.10 *protective component, n*—any component used for protection from sharp edges, points, or entrapment of fingers or toes.

3.1.10.1 *Discussion*—

Examples of protective components include caps, sleeves, and plugs.

3.1.11 *static load, n*—vertically downward load applied by weights or other means.

3.1.12 *structural component, n*—any load bearing member or part of the product that supports the weight or portion of the weight of the occupant.

3.1.13 *tethered strap, n*—a strap that is used to secure, anchor, or attach the restraint system or seat to another part of the product’s frame. (See 6.9.)

3.1.13.1 *Discussion*—

This specifically excludes straps that are loose or hanging from a product that are not intended to be attached to another component according to the manufacturer’s instructions.

3.1.14 *travel swing, n*—a low-profile, compact infant, cradle, or combination swing having a distance of 6 in. or less between the underside of the seat bottom and the support surface (floor) at any point in the seat’s range of motion.

#### 4. Calibration and Standardization

4.1 All testing shall be conducted on a concrete floor that may be covered with 1/8 in. (3 mm) thick vinyl floor covering, unless test instructs differently.

4.2 The product shall be completely assembled, unless otherwise noted, in accordance with the manufacturer’s instructions.

4.3 No testing shall be conducted within 48 h of manufacturing.

4.4 The product to be tested shall be in a room with an ambient temperature of 73 °F ± 9 °F (23 °C ± 5 °C) for at least 1 h prior to testing. Testing then shall be conducted within this temperature range.

4.5 All testing required by this specification shall be conducted on the same product.

#### 5. General Requirements

5.1 *Hazardous Sharp Edges or Points*—There shall be no hazardous sharp points or edges as defined by 16 CFR 1500.48 and 16 CFR 1500.49 before and after testing to the consumer safety specification.

<https://standards.iteh.ai/catalog/standards/sist/2653bfe4-abd5-4327-81a0-08d78a42d322/astm-f2088-22>

5.2 *Small Parts*—There shall be no small parts as defined by 16 CFR 1501 before testing or liberated as a result of this testing to this specification.

5.3 The paint and surface coating on the product shall comply to 16 CFR 1303.

5.4 *Wood Parts*—Prior to testing, any exposed wood parts shall be smooth and free from splinters.

5.5 *Scissoring, Shearing, Pinching*—The product, when in the manufacturer’s recommended use position(s), shall be designed and constructed so as to prevent injury to the occupant from any scissoring, shearing, or pinching when members or components rotate about a common axis or fastening point, slide, pivot, fold, or otherwise move relative to one another. Scissoring, shearing, or pinching that may cause injury exists when the edges of the rigid parts admit a probe greater than 0.210 in. (5.33 mm) and less than 0.375 in. (9.53 mm) in diameter at any accessible point throughout the range of motion of such parts.

5.6 *Openings*—Holes or slots that extend entirely through a wall section of any rigid material less than 0.375-in. (9.53-mm) thick and admit a 0.210-in. (5.33-mm) diameter rod shall also admit a 0.375-in. (9.53-mm) diameter rod. Holes or slots that are between 0.210-in. (5.33-mm) and 0.375-in. (9.53-mm) and have a wall thickness less than 0.375-in. (9.53-mm), but are limited in depth to 0.375-in. (9.53-mm) maximum by another rigid surface shall be permissible (see Fig. 3). The product shall be evaluated in all manufacturer’s recommended use positions.

5.7 *Exposed Coil Springs*—Any exposed coil spring which is accessible to the occupant, having or capable of generating a space between coils of 0.210 in. (5.33 mm) or greater during static load testing (see 7.3.2) shall be covered or otherwise designed to prevent injury from entrapment.

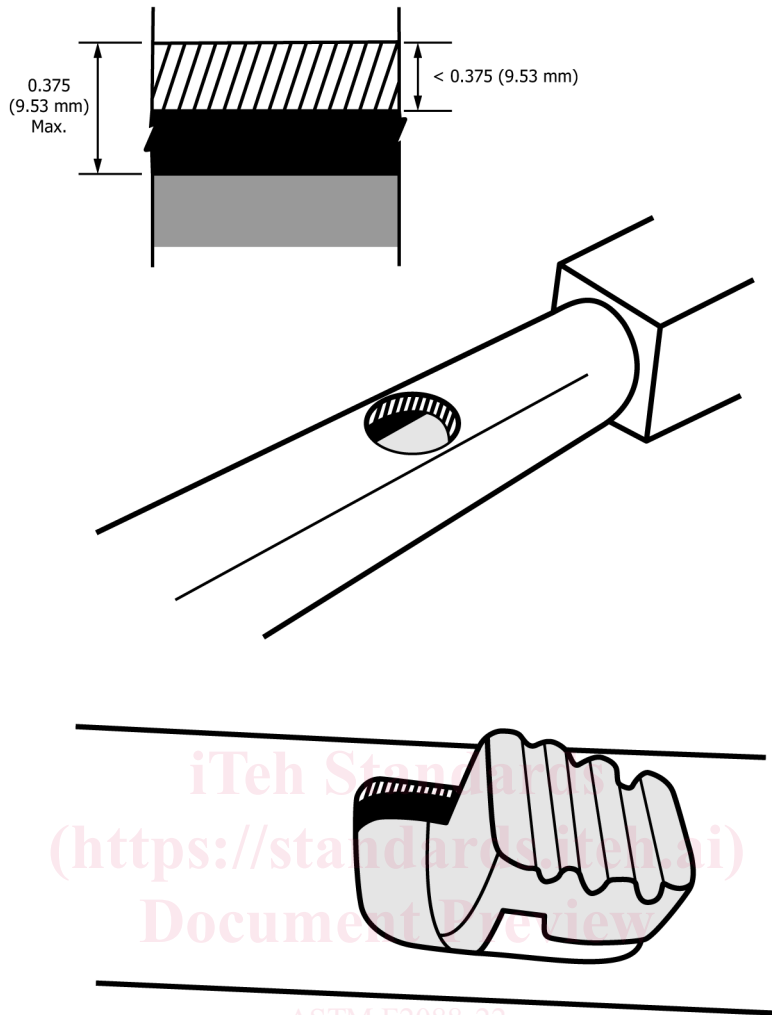

FIG. 3 Opening Examples

<https://standards.iteh.ai/catalog/standards/sist/265561e4-abd5-4327-81a0-08d78a42d322/astm-f2088-22>

5.8 *Protective Components*—If a child can grasp components between the thumb and forefinger, or teeth, or if there is at least a 0.04 in. (1.0 mm) gap between the component and its adjacent parent component, such component shall not be removed when tested in accordance with 7.2. All protective components that are accessible to a child in the product or accessible to a child from any position around the product shall be evaluated.

5.9 *Labeling:*

5.9.1 Warning labels, (whether paper or non paper) shall be permanent when tested per 7.8.

5.9.2 Warning statements applied directly onto the surface of the product by hot stamping, heat transfer, printing, wood burning, etc. shall be permanent when tested per 7.9.

5.9.3 Non-paper labels shall not liberate small parts when tested in accordance with 7.10.

5.10 *Toys*—Toy accessories attached to, removable from, or sold with a swing, as well as their means of attachment, shall comply with the applicable requirements of Consumer Safety Specification F963.

5.10.1 Toy mobiles that attach solely to a swing are not required to contain labeling as stated in Consumer Safety Specification F963, Section 5, Safety Labeling for Mobiles, and Section 6, Instructional Literature for Mobiles.

5.10.2 Toy mobiles included with the swing that have toys within the reach of the occupant shall not detach rigid components when tested in accordance with 7.12. Detachment of a soft toy only is not considered a failure.

NOTE 1—The intent is to exempt soft items that would not result in impact injury if the occupant was struck by that component. Examples are soft filled toys, stuffed toys, and pliable toys.

5.11 Cradle swings or combination swings in a cradle swing use, mode, or position while in the rest (non-rocking) position shall comply with the requirements of Consumer Safety Specification F2194.

## 6. Performance Requirements

6.1 *Electrically Powered Swings (remote control devices are exempt from the requirements in 6.1):*

6.1.1 Each battery compartment shall provide a means to contain the electrolytic material in the event of a battery leakage. This containment means shall not be accessible to the occupant.

6.1.2 Positive protection from the possibility of charging any primary (non-rechargeable) battery shall be achieved either through physical design of the battery compartment or through the use of appropriate electrical circuit design. This applies to situations in which a battery may be installed incorrectly (reversed), and in which a battery charger may be applied to a product containing primary batteries. This section does not apply to a circuit having one or two batteries as the only source of power.

6.1.3 The surfaces of any accessible electrical component, including batteries, shall not achieve temperatures exceeding 160 °F (71 °C) when tested in accordance with 7.1. At the conclusion of the test, there shall be no battery leakage or, explosion or a fire to any electrical component. This test shall be performed prior to conducting any other testing within the performance requirements section.

6.1.4 AC adapters supplied with the product must denote compliance with the appropriate current national safety standard for AC adapters from a Nationally Recognized Testing Laboratory (NRTL). AC adaptors must have a nominal output voltage less than 30 VDC (42.4 VAC (peak)) and must not be capable of delivering more than 8 amps into a variable resistive load for one minute.

NOTE 2—Refer to UL 1310 for Class II output definitions and evaluation. <https://standards.iteh.ai>

NOTE 3—NRTLs are organizations recognized by OSHA in accordance with 29 CFR 1910.7 to test and certify equipment or materials (products) requiring approval by certain OSHA safety standards. A current list of NRTLs can be found at <http://www.osha.gov/dts/otpca/nrtl/nrtllist.html>.

6.2 *Structural Integrity*—All tests that cover static and dynamic loading are to be performed sequentially on the same product and in the sequence listed in the standard without refurbishing or repositioning of adjustment, if any.

6.2.1 *Dynamic Load*—The swing shall support a dynamic load and there shall be no failure of seams, breakage of materials, or changes of adjustments that could cause the product to not fully support the child or create a hazardous condition as defined in Section 5 after testing in accordance with 7.3.1.

6.2.2 *Static Load*—The swing shall support a static load and there shall be no failure of seams, breakage of materials, or changes of adjustments that could cause the product to not fully support the child or create a hazardous condition as defined in Section 5 after testing in accordance with 7.3.2.

6.3 *Stability Test*—The swing shall not tip over when tested according to 7.4.

6.4 *Unintentional Folding*—The swing shall remain in the manufacturer's recommended use position(s) when tested per 7.5. If a product is designed with a latching or locking device, that device shall remain engaged and operative after testing.

6.4.1 Threaded fasteners used to attach structural components shall have a locking mechanism such as lock washers, self-locking nuts or other means to prevent detachment due to vibration.

6.5 *Restraint System*—A restraint system shall be provided to secure an occupant in an infant swing in the seated positions in any

of the manufacturer's recommended use positions. Cradle swings and combination swings when in all manufacturer's use positions as a cradle swing shall not have a restraint system.

6.5.1 The restraint system shall include both waist and crotch restraint designed such that the crotch restraint's use is mandatory when the restraint system is in use.

6.5.2 Infant swings with a maximum seat back angle greater than 50° from horizontal measured in accordance with 7.13 shall include shoulder straps as part of the restraint system.

6.5.3 This system and its closing means shall not slip more than 1 in. (25 mm), break, separate, or permit the removal of the test dummy when tested per 7.6.

6.5.4 A connecting means and adjustment means for the waist restraint shall be capable of usage independent of one another. The connecting means shall not be an adjustment means but may have one integrally attached to it.

6.5.5 Before shipment, the restraint system must be attached to the infant swing in such a manner as to not become detached through normal use.

6.5.6 If the swing seat has a tray or other component that creates a completely bounded opening in front of the occupant, a passive crotch restraint system shall be included and designed such that its use is mandatory when the tray or other component is in use.

6.6 *Passive Crotch Restraint System*—For products with a tray or other component that creates a completely bounded opening in front of the occupant.

6.6.1 There shall be no vertical gap between the passive crotch restraint and either the tray or seating surface that allows free passage of a 1.5-in. (38-mm) diameter by 3-in. (76-mm) long rod from one leg opening to the other.

6.6.2 The leg openings on each side of the passive crotch restraint shall not allow complete passage of the wedge block when tested in accordance with 7.11.

6.7 *Cradle Swing Orientation*—The angle of the cradle swing surface along the dummy's head-to-toe axis relative to the horizontal shall not be greater than 5° when tested in accordance to 7.7.

6.8 *Seat Angles for Swings with Removable Tray/Armbar or Without Tray/Armbar:* [a0-08d78a42d322/astm-f2088-22](https://www.astm.org/standards/F2088-22)

6.8.1 Products with a horizontal axis of swing motion shall meet the requirements described in 6.8.1.1 or 6.8.1.2.

6.8.1.1 The angle between the seat back and horizontal shall be:

less than 60° for full size swings

less than 45° for travel swings

and the angle between the seat bottom and horizontal shall be 30° or greater when tested in accordance with 7.14.

6.8.1.2 The product shall include shoulder straps as part of the restraint system.

6.8.2 Products with other than horizontal axis of swing motion shall meet the requirements described in 6.8.2.1 or 6.8.2.2.

6.8.2.1 The angle between the seat bottom and horizontal shall be 5° or greater when tested in accordance with 7.15.

6.8.2.2 The product shall include shoulder straps as part of the restraint system.

6.9 *Tethered Strap Accessibility for Non-Occupants*—For any products that have a tethered strap (see 3.1.13) that is accessible on the underside of the seat, the maximum length of the strap shall not exceed 16 in. (406 mm) when tested in accordance with 7.16.

## 7. Test Methods

7.1 The swing shall be tested using fresh alkaline batteries or an AC power source. If the swing can be operated using both, then both batteries and AC power must be tested separately. If another battery chemistry is specifically recommended for use in the

15 lbf (67 N)  
Maximum Tension

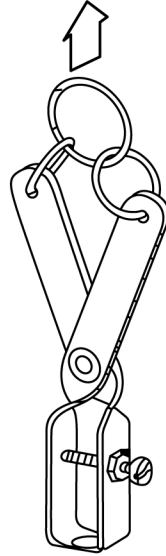

FIG. 4 Tension Test Adapter/Clamp

swing by the manufacturer, repeat the test using the batteries specified by the manufacturer. If the swing will not operate using alkaline batteries, then test with the type of battery recommended by the manufacturer at the specified voltage. The test is to be carried out in a draft-free location, at an ambient temperature of  $68^{\circ}\text{F} \pm 9^{\circ}\text{F}$  ( $20^{\circ}\text{C} \pm 5^{\circ}\text{C}$ ).

7.1.1 Secure the swing so that the seat cannot move during the test. Operate the swing at the maximum speed. Do not disable any mechanical or electrical protective device, such as clutches or fuses. Operate the swing continuously, and record peak temperature. The test shall be discontinued 60 min after the peak temperature is recorded. If the swing shuts off automatically or must be kept “on” by hand or foot, monitor temperatures for 30 s, resetting the swing as many times as necessary to complete the 30 s of operation. If the swing shuts off automatically after an operating time of greater than 30 s, continue the test until the swing shuts off.

ASTM F2088-22

7.2 Removal of Protective Components Test:

7.2.1 Any protective component shall be tested in accordance with each of the following methods in the sequence listed.

7.2.2 Secure the product so that the product cannot move during the performance of the following tests:

7.2.3 *Torque Test*—Gradually apply a torque of 2 lbf-in. (0.2 Nm) over a period of 5 s in a clockwise direction until a rotation of  $180^{\circ}$  from the original position has been attained or 2 lbf-in. (0.2 Nm) has been exceeded. The torque or maximum rotation shall be maintained for an additional 10 s. The torque shall then be removed and the test components permitted to return to a relaxed condition. This procedure shall then be repeated in the counter-clockwise direction.

7.2.4 *Tension Test:*

7.2.4.1 Attach a force gauge to the protective component by means of any suitable device. For components that cannot reasonably be expected to be grasped between thumb and forefinger, or teeth, on their outer diameter but have a gap of 0.04 in. (1.0 mm) or more between the rear surface of the component and the structural member of the product to which they are attached, a clamp such as the one shown in Fig. 4 may be a suitable device.

7.2.4.2 Be sure that the attachment device does not compress or expand the component hindering any possible removal.

7.2.4.3 Gradually apply a force of 15 lbf. (67 N) over a period of 5 s in the direction that would normally be associated with the removal of the protective component. Hold for an additional 10 s.

7.3 *Structural Integrity:*



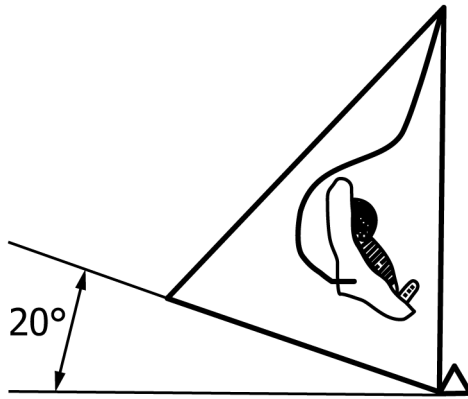

FIG. 5 Stability Test

### 7.3.1 Dynamic Load:

7.3.1.1 *Test Equipment*—Shot bag, 6 in. to 8 in. (15 cm to 20 cm) diameter bag filled with shot; total weight 25 lb (11.4 kg).

7.3.1.2 Set-up the swing in accordance with the manufacturer’s instructions. If the swing seat has more than one height position, recline position, facing direction, tray position, or other adjustable feature position, test the product in the configuration most likely to fail.

7.3.1.3 Place the shot bag on the seating surface of the swing and allow swinging motion to come to rest. Secure the swing so that the seat cannot move during the test. The means of securing the seat shall not affect the outcome of the test. Raise the shot bag a distance of 1 in. (25 mm) above the seat of the swing. Drop the weight onto the seat 500 times with a cycle time of  $4\text{ s} \pm 1\text{ s}$  per cycle. The drop height is to be adjusted to maintain the 1 in. (25 mm) drop height as is practical.

### 7.3.2 Static Load Test:

7.3.2.1 *Test Equipment*—Wood block, 6 in. by 6 in. by  $\frac{3}{4}$  in. (150 mm by 150 mm by 19 mm).

7.3.2.2 Place a static load of 75 lb (34.1 kg) or 3 times the manufacturer’s maximum recommended weight, whichever is greater, in the center of the seat distributed by a wood block. Gradually apply the weight within 5 s and maintain for 60 s.

### 7.4 Stability Test:

#### 7.4.1 Test Equipment:

7.4.1.1 *CAMI Mark II Dummy*, 17.5 lb (8 kg) (see 2.4 and Fig. 1).

7.4.1.2 *Inclined Surface*—A smooth inclined surface with a 1 in. by 1 in. (25 mm by 25 mm) stop or equivalent device mounted parallel to the lower edge of the surface and parallel to the floor so as to prevent the swing from sliding, but not prevent it from tipping.

#### 7.4.2 Stability in the Direction of Swing Motion:

7.4.2.1 Adjust the inclined surface to  $20^\circ$  from horizontal.

7.4.2.2 Place the CAMI Dummy Mark II in the swing seat.

7.4.2.3 For a product with a horizontal axis of swing motion, position the product on the inclined surface with the axis of swinging motion parallel to the stop and the lower most frame member(s) in contact with the stop as shown in Fig. 5. If the swing seat has more than one height position, recline position, facing direction, direction of motion, tray position, or other adjustable feature position, test the product in the configuration most likely to fail. Rotate the swing frame  $180^\circ$  and repeat the procedure.

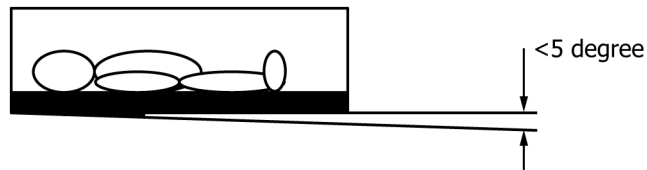

FIG. 6 Cradle Swing Angle Measurement

7.4.2.4 For a product with other than horizontal axis of swing motion, position the product on the inclined surface in the most onerous swing orientations such that the product is in contact with the stop. If the swing seat has more than one height position, recline position, facing direction, direction of motion, tray position, or other adjustable feature position, test the product in the configuration most likely to fail.

#### 7.5 Unintentional Folding Test:

7.5.1 With the product in the manufacturer's recommended use position, apply a force of 10 lbf (45 N) at the end of a leg in the direction normally associated with folding, while holding opposite leg(s) stationary. Gradually apply the force over 5 s and maintain for an additional 10 s. Repeat this test on each leg.

#### 7.6 Restraint System Test:

7.6.1 Secure the swing seat so that it cannot move.

7.6.2 Apply a force of 35 lbf (156 N) to a single attachment point of the restraint system in the normal use direction(s) in which stress would be applied to that attachment. Gradually apply the force within 5 s and maintain for an additional 10 s. Repeat a total of five times with a maximum interval of 2 s between tests. Repeat for each attachment point of the restraint system and each fastening device.

7.6.3 Place the CAMI Infant Dummy, Mark II in the swing seat with the restraining system engaged according to the manufacturer's instructions. Tighten the restraint system in such a manner that you can comfortably slide your little finger between the strap and the test dummy. Perform the following test without readjusting the restraining system. Gradually apply a pull force of 35 lbf. (156 N) horizontally to either leg of the test dummy. Gradually apply the force within 5 s and maintain for an additional 10 s. Repeat this procedure a total of 5 times with a maximum of 2 s between test.

#### 7.7 Cradle Swing Orientation Test:

7.7.1 *Dynamic Angle*—Place the CAMI Newborn Dummy (7.5 lb) into the cradle with its back on the support surface in the most disadvantageous position. The dummy's head-to-toe centerline must remain parallel to the head-to-toe centerline of the support surface.

7.7.1.1 Start the swing in motion in accordance with the manufacturer's instructions. Measure the angle of the bed surface along the CAMI's head-to-toe axis relative to the horizontal. The angle shall be less than 5° as shown in Fig. 6.

7.7.2 *Static Angle*—Place the CAMI newborn dummy into the cradle swing with its back on the support surface in the most disadvantageous position. Measure the angle of the bed surface along the CAMI's head-to-toe axis relative to the horizontal. The angle shall be less than 5° as shown in Fig. 6.

#### 7.8 Permanency of Labels and Warnings:

7.8.1 A paper label (excluding labels attached by a seam) shall be considered permanent if, during an attempt to remove it without the aid of tools or solvents, it cannot be removed, it tears into pieces upon removal, or such action damages the surface to which it is attached.

7.8.2 A non-paper label (excluding labels attached by a seam) shall be considered permanent if, during an attempt to remove it without the aid of tools or solvents, it cannot be removed or such action damages the surface to which it is attached.

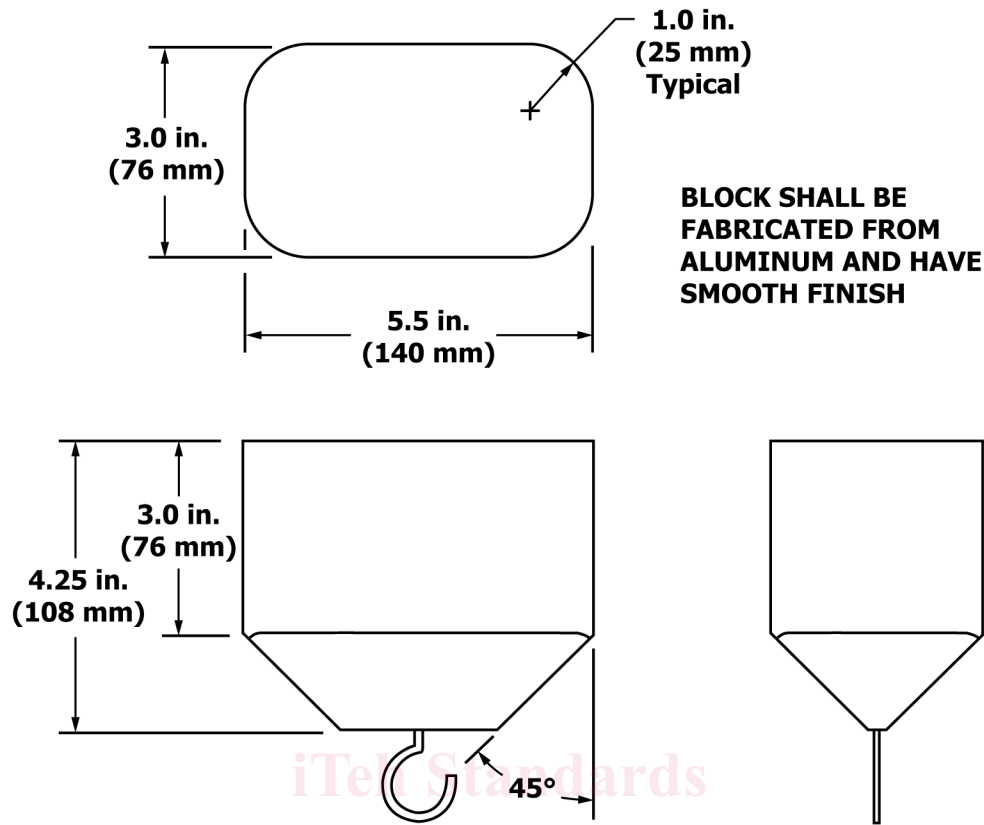

NOTE 1—Not to scale.  
FIG. 7 Torso Probe

7.8.3 A warning label attached by a seam shall be considered permanent if it does not detach when subjected to a 15 lbf (67 N) pull force applied in the direction most likely to cause a failure using a  $\frac{3}{4}$  in. (19 mm) diameter clamp surface. Apply the force evenly over 5 s and maintain for an additional 10 s.

7.9 Adhesion Test for Warnings Applied Directly onto the Surface of the Product:

7.9.1 Apply the tape test defined in Test Method B—Cross-Cut Tape Test of Test Methods D3359 eliminating parallel cuts.

7.9.2 Perform this test once in each different location where warnings are applied.

7.9.3 The warning statements will be considered permanent if the printing in the area tested is still legible and attached after being subjected to this test.

7.10 A non-paper label, during an attempt to remove it without the aid of tools or solvents, shall not be removed or shall not fit entirely within the small parts cylinder defined in 16 CFR 1501 if it can be removed.

7.11 Leg Openings Test:

7.11.1 Secure the chair in its normal standing position so that it cannot move in the direction of the force being applied. Attach the tray in the position that creates the largest leg openings.

7.11.2 Into each leg opening, insert the tapered end of the wedge block, shown in Fig. 7, in the most adverse orientation. Apply a 25-lbf (111-N) force perpendicular to the base of the probe. The force shall be applied gradually within 5 s and maintained for an additional 10 s.

7.11.3 Repeat this procedure with the tray removed if a completely bounded opening exists after the tray is removed.