



Designation: **F1955—20** **F1955 – 22**

An American National Standard

## Standard Test Method for Flammability of Sleeping Bags<sup>1</sup>

This standard is issued under the fixed designation F1955; the number immediately following the designation indicates the year of original adoption or, in the case of revision, the year of last revision. A number in parentheses indicates the year of last reapproval. A superscript epsilon ( $\epsilon$ ) indicates an editorial change since the last revision or reapproval.

### 1. Scope

1.1 This fire-test response test method contains a method to assess the flammability, expressed as a burn rate, of sleeping bags which use various materials and constructions in their manufacture.

1.2 Sleeping bags that comply with the requirements in this test method shall be permitted to be labeled as complying with the appropriate requirements, to facilitate the identification of products conforming to this test method.

1.3 This test method is technically equivalent to the flammability standard CPAI-75, issued by the Industrial Fabrics Association International (see 2.2), and which has been in use as a flammability requirement for the sleeping bag industry in the U.S.

NOTE 1—CPAI-75 expresses burn rate in units of inches/minute while this test method expresses burn rate in units of centimetres/minute.

1.4 The values stated in SI units are to be regarded as the standard. The values given in parentheses are for information only.

1.5 *This standard is used to measure and describe the response of materials, products, or assemblies to heat and flame under controlled conditions, but does not by itself incorporate all factors required for fire hazard or fire risk assessment of the materials, products, or assemblies under actual fire conditions.*

1.6 *This standard does not purport to address all of the safety concerns, if any, associated with its use. It is the responsibility of the user of this standard to establish appropriate safety, health, and environmental practices and determine the applicability of regulatory limitations prior to use.*

1.7 *Fire testing is inherently hazardous. Adequate safeguards for personnel and property shall be employed in conducting these tests.*

1.8 *This international standard was developed in accordance with internationally recognized principles on standardization established in the Decision on Principles for the Development of International Standards, Guides and Recommendations issued by the World Trade Organization Technical Barriers to Trade (TBT) Committee.*

### 2. Referenced Documents

#### 2.1 ASTM Standards:<sup>2</sup>

[D123 Terminology Relating to Textiles](#)

[D1776 Practice for Conditioning and Testing Textiles](#)

[D5025 Specification for Laboratory Burner Used for Small-Scale Burning Tests on Plastic Materials](#)

[E136 Test Method for Assessing Combustibility of Materials Using a Vertical Tube Furnace at 750°C](#)

<sup>1</sup> This test method is under the jurisdiction of ASTM Committee F08 on Sports Equipment, Playing Surfaces, and Facilities and is the direct responsibility of Subcommittee F08.22 on Camping Softgoods.

Current edition approved Oct. 1, 2020/May 1, 2022. Published October 2020/May 2022. Originally approved in 1999. Last previous edition approved in 2015/2020 as F1955—15/F1955 – 20. DOI: 10.1520/F1955-20.10.1520/F1955-22.

<sup>2</sup> For referenced ASTM standards, visit the ASTM website, www.astm.org, or contact ASTM Customer Service at service@astm.org. For *Annual Book of ASTM Standards* volume information, refer to the standard's Document Summary page on the ASTM website.

E176 Terminology of Fire Standards

2.2 Industrial Fabrics Association International Standard:<sup>3</sup>

Specification CPAI-75 A Rate of Burn Standard for Sleeping Bags

2.3 AATCC Standard:<sup>4</sup>

Test Method 124 - 2006 Appearance of Fabrics after Repeated Home Laundering - Laboratory Procedure 1 (LP 1)-2018 Home Laundering: Machine Washing

### 3. Terminology

3.1 *Definitions*—For definitions of terms used in this test method associated with fire issues, refer to Terminology E176. For definitions of terms used in this test method associated with textile issues, refer to Terminology D123.

3.2 *Definitions of Terms Specific to This Standard:*

3.2.1 *burn rate, n*—the distance traveled by a flame on a burning material or product during a specified time under specified conditions.

3.2.2 *combustible, adj*—capable of undergoing combustion.

3.2.2.1 *Discussion*—

The term combustible is often delimited to specific fire-exposure conditions.

3.2.3 *sleeping bag, n*—a structure made of down, synthetic fiberfill, shell fabrics, and/or other materials, that is designed for thermal protection while sleeping (for example, outdoors, tent, cabin).

### 4. Summary of Test Method

4.1 Ten specimens are cut from individual sleeping bags or from a physically accurate facsimile.

4.2 Five of these specimens shall be tested as received (after conditioning).

4.3 The other five specimens shall be cleaned in accordance with 7.3 and then conditioned. These specimens shall also then be tested, after conditioning.

4.4 Each of the specimens to be tested is placed in the test apparatus. A standardized flame is applied to the folded edge for a specified time under controlled conditions and the burn rate is calculated to determine if the specimens meet the performance requirements.

### 5. Significance and Use

5.1 This test method is suitable to assess the fabric burn rate of sleeping bag fabrics.

5.2 This test method is applicable to all sleeping bags.

5.3 This test method is technically equivalent to CPAI-75, which is used for the acceptance of commercial shipments of sleeping bags.

5.4 ~~When combustible fabrics are used for sleeping bags they are potentially dangerous to the user because of their ease of ignition (since all combustible materials will ignite) and because it is possible that they will exhibit a high burn rate.~~

5.4 Most ~~fabrics~~ materials used to make sleeping bags are organic materials and are combustible (see 3.2.2). Fabrics-Sleeping bag materials can be combustible due to the inherent chemical composition of the ~~fabrie~~ material or due to the finishing processes used, or both.

<sup>3</sup> Support for Specification CPAI-75 is to be discontinued by the Industrial Fabrics Association International and replaced with Test Method F1955.

<sup>4</sup> Available from American Association of Textile Chemists and Colorists (AATCC), P.O. Box 12215, Research Triangle Park, NC 27709-2215, <http://www.aatcc.org>.

~~5.5.1 Optionally, if there is a query as to whether a specific fabric used for a sleeping bag is combustible, it shall be tested in accordance with Test Method E136. If the fabric complies with the requirements of Test Method E136 it shall be considered noncombustible and shall be deemed to meet the performance requirements of this test method.~~

5.5 When exposed to fire, combustible sleeping bag materials are potentially dangerous to the user because of their ease of ignition and because it is possible that they will exhibit a high burning rate.

5.5.1 If the sleeping bag material is noncombustible, it shall be deemed to meet the performance requirements of this test method. One way of demonstrating noncombustibility is by meeting the requirements of Test Method E136.

5.6 Changes in finishes or in fabric surface treatments can exert a large effect on the fabric flammability. Therefore, sleeping bags shall be tested both before and after cleaning or aging in accordance with one of the procedures in 7.3, in accordance with the manufacturer's instructions.

5.7 In this procedure, the specimens are subjected to one or more specific sets of laboratory test conditions. If different test conditions are substituted or the end-use conditions are changed, it is not always possible by or from this test method to predict changes in the fire-test-response characteristics measured. Therefore, the results are valid only for the fire test exposure conditions described in this procedure.

5.8 It must be understood, moreover, that no guarantee can be given and none is implied that sleeping bags complying with the performance requirements of this test method will not be hazardous under certain conditions.

5.9 It is feasible that the fabric will pass the test requirements as received but fail the requirements after cleaning. In that case, the report shall indicate that the fabric is not suitable for cleaning or aging (as appropriate).

## 6. Sampling

6.1 *Lot Size*—A lot shall be considered the size of the contract between the buyer and the supplier unless otherwise agreed upon between the supplier and the buyer.

6.2 All specimens shall be selected randomly from the lot.

6.3 *Sample Unit*—A sample unit shall consist of ten specimens.

## 7. Test Specimens

7.1 *Test Specimens*—A total of ten test specimens shall be taken from the sleeping bag as shown in Fig. 1 and shall have a finished size of 30 by 36 cm (12 by 14 in.).

7.2 In the event that it is impossible to cut an actual sample from a sleeping bag due to its construction, a 30 by 71-cm (12 by 28-in.) facsimile shall be permitted to be constructed and folded. All components shall be used in their correct positions and amounts.

7.3 *Cleaning*—Five of the ten test specimens to be tested shall be cleaned in accordance with one of the procedures shown below:

7.3.1 If a laundering procedure is provided by the manufacturer, the fabric test specimens shall be laundered, in accordance with the procedures recommended by the manufacturer, by undergoing three wash-and-dry cycles.

7.3.2 If a dry-cleaning procedure is provided by the manufacturer, the fabric test specimens shall be dry cleaned three times in accordance with the procedures recommended by the manufacturer.

~~7.3.3 If no laundering or dry-cleaning procedure is provided by the manufacturer, the fabric manufacturer's laundering instruction is provided, the test specimens shall be laundered as specified per AATCC LP1-2018e, *Laboratory Procedure for Home*~~

DIMENSION IN CM (IN)

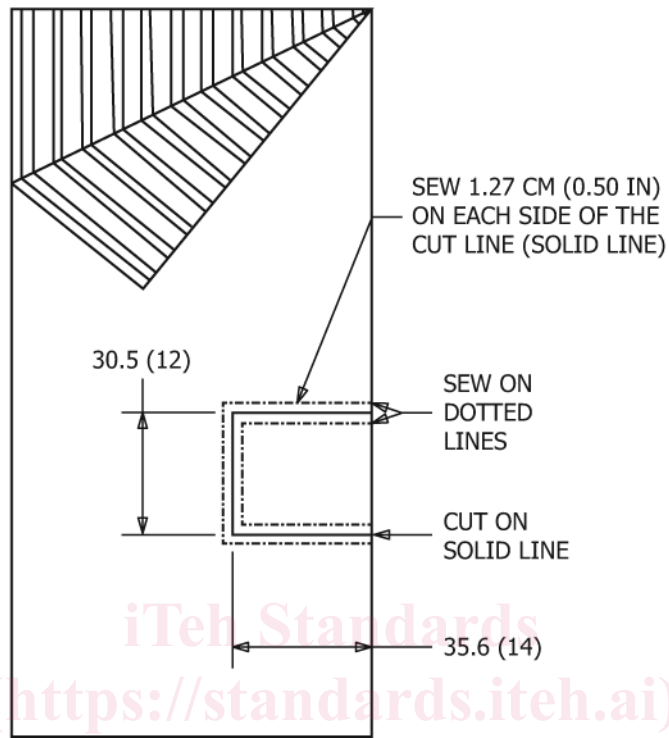

FIG. 1 Test Specimen

Laundering: Machine Washing, in AATCC Test Method 124, by undergoing three wash-and-dry cycles: at machine wash warm, in normal cycle ((1) found in Table I), followed by tumble dry normal ((Procedure Ai) found in Table VI). Repeat for a total of three times.

7.4 *Compression*—Samples shall be compressed to one half their original loft for 24 h prior to testing (see [Note 2](#)).

NOTE 2—An easy method of accomplishing this compression is to stack a number of specimens in a box and compress them all to half their original height under a board or plate held down by pins through the side of the box, and so forth.

7.5 *Re-Lofting*—Following the 24-h compression period, the specimens shall be allowed a minimum of 1 h to regain their loft before tests are conducted.

## 8. Conditioning

8.1 Condition the fabrics to be tested in accordance with the recommendations of Practice [D1776](#) as related to textile test specimens. Fabrics shall be conditioned to moisture equilibrium (constant weight) at an ambient temperature of  $23 \pm 3^\circ\text{C}$  ( $73 \pm 5^\circ\text{F}$ ) and a relative humidity of  $50 \pm 5\%$ .

8.2 Conduct all tests in the conditioning room (8.1) or within 15 min of removal from the conditioning room atmosphere. After conditioning, specimens shall not be exposed to an environment with an uncontrolled relative humidity for more than 15 min prior to testing.

8.3 All testing shall be performed in a draft-free environment.

9. Apparatus

9.1 *Test Chamber*—Use the test chamber shown in Fig. 2 for testing. Place the test chamber under or in some type of exhaust or fume hood to allow for the venting of the fumes and smoke associated with the test method.

9.2 *Support Frame*—Use a support frame conforming to Fig. 3 to mount the test specimen. The support frame shall be constructed of 3-mm (1/8-in.) steel.

9.3 *Hold-Down Plate*—Use a hold down plate conforming to Fig. 4 for testing. It shall be constructed of 3-mm (1/8-in.) steel.

9.4 *Spacers and Clamps*—A spacer and clamping arrangement shall be used which is capable of positioning the hold-down plate with its bottom surface 25 mm (1 in.) above the top surface of the support frame, so that it will hold the test specimen at a 25 mm (1 in.) thickness on the two sides and the back.

9.5 *Thread*—Use #50 white mercerized cotton thread.

9.6 *Tape*—Use tape or an alternate method (such as small clips) for fastening the thread to the frame.

9.7 *Weights*—Use weights (for example small clamp-type paper clips) to attach to the timing threads.

9.8 *Burner*—The burner shall consist of a barrel that threads onto a one-piece base and gas inlet. The components shall be constructed of metal, typically of brass or aluminum.

9.8.1 *Burner Barrel*—The burner barrel shall consist of a mixing tube and threaded air-inlet adapter. The mixing tube shall be of seamless construction, with an inside diameter of  $9.5 \pm 0.3$  mm. The length of the barrel from the top of the air-inlet openings to the top of the mixing tube shall be  $100 \pm 10$  mm. The top of the mixing tube shall not be equipped with end attachments, such as stabilizers. The air inlet adapter, located at the bottom of the mixing tube, shall be approximately 25 mm high and 20 mm in overall diameter. The minimum area of the air-inlet openings shall be  $225 \text{ mm}^2$  distributed equidistant around the adapter. With the barrel fully screwed into the base and the lock nut in place, the air-inlet openings shall be completely closed.

NOTE 3—The requirement for the minimum area of the air-inlet openings has commonly been obtained with three openings, approximately 6.5 by 12.5 mm.

ITEM	NO. REQUIRED	DESCRIPTION, CM (IN)
1.	4	CORNER ANGLE, 2.5 X 71.1 (1 X 28)
2.	4	WINDOW FRAME, 7.6 X 71.1 (3 X 28)
3.	4	FRAME SPACER, 4.45 X 10.2 (1-3/4 X 4)
4.	4	WINDOW SEAT, 3.18 X 10.2 (1-1/4 X 4)
5.	1	WINDOW - HEAT RESISTANT GLASS 0.476 X 50.8 X 50.8 (3/16 X 20 X 20)
6.	3	PANEL, 60.96 X 60.96 (24 X 24)
7.	1	TOP PLATE, 62.0 X 66.0 (24-1/2 X 26)
8.	2	CHAIN, 61 (24)
9.	2	WINDOW STOP RODS, 6 MM DIA. X 10 CM (1/4 DIA X 4)
10.	4	S HOOKS
11.	22	BOLT WITH NUT, 6 MM - 25 X 2 CM (1/4-20 X 3/4)
12.	6	BOLT WITH NUT, 10 MM - 32 X 1 CM (10 - 24 X 1/2)
13.	2	HOLE, 6 MM DIA (1/4 IN DIA)

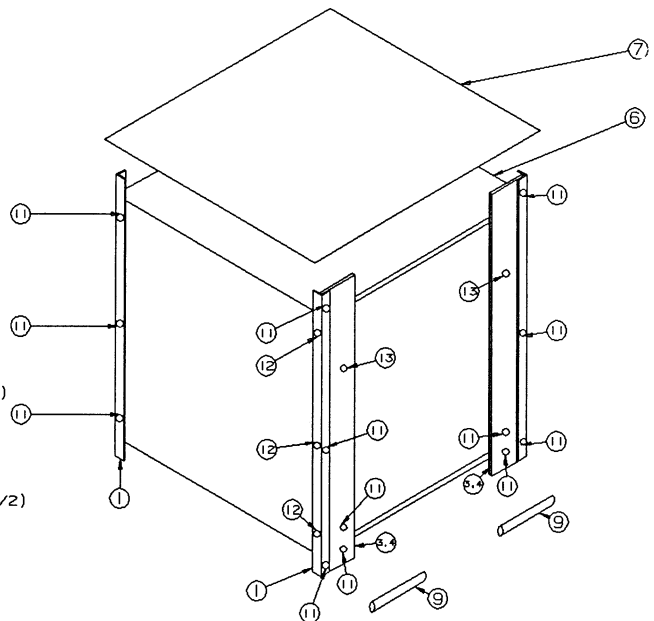

FIG. 2 Test Chamber