



Designation: D4986 – 22

# Standard Test Method for Horizontal Burning Characteristics of Cellular Polymeric Materials<sup>1</sup>

This standard is issued under the fixed designation D4986; the number immediately following the designation indicates the year of original adoption or, in the case of revision, the year of last revision. A number in parentheses indicates the year of last reapproval. A superscript epsilon ( $\epsilon$ ) indicates an editorial change since the last revision or reapproval.

## 1. Scope\*

1.1 This fire-test-response standard contains a test method for small-scale laboratory procedures to be used to determine the relative rate of burning and the extent and time of burning of horizontally oriented cellular polymeric materials having a density less than 250 kg/m<sup>3</sup>.

1.2 The results are intended to serve as a preliminary indication of their acceptability with respect to flammability for a particular application. The final acceptance of the material is dependent upon its use in the end-product that conforms with the standards applicable to such end-product.

1.3 The classification system described in the [Appendix X1](#) is intended for quality assurance and the preselection of component materials for products.

1.4 *This standard measures and describes the response of materials, products, or assemblies to heat and flame under controlled conditions, but does not by itself incorporate all factors required for fire hazard or fire risk assessment of the materials, products, or assemblies under actual fire conditions.*

1.5 The values stated in SI units are to be regarded as standard.

1.6 *This standard does not purport to address all of the safety concerns, if any, associated with its use. It is the responsibility of the user of this standard to establish appropriate safety, health, and environmental practices and determine the applicability of regulatory limitations prior to use.* For a specific hazard statement, see [6.1.1](#).

1.7 *Fire testing is inherently hazardous. Adequate safeguards for personnel and property shall be employed in conducting these tests.*

NOTE 1—This test method is equivalent to ISO 9772.

1.8 *This international standard was developed in accordance with internationally recognized principles on standardization established in the Decision on Principles for the Development of International Standards, Guides and Recom-*

*mendations issued by the World Trade Organization Technical Barriers to Trade (TBT) Committee.*

## 2. Referenced Documents

2.1 *ASTM Standards:*<sup>2</sup>

[D883 Terminology Relating to Plastics](#)

[D1622 Test Method for Apparent Density of Rigid Cellular Plastics](#)

[D4483 Practice for Evaluating Precision for Test Method Standards in the Rubber and Carbon Black Manufacturing Industries](#)

[D5025 Specification for Laboratory Burner Used for Small-Scale Burning Tests on Plastic Materials](#)

[E176 Terminology of Fire Standards](#)

[E456 Terminology Relating to Quality and Statistics](#)

[E2016 Specification for Industrial Woven Wire Cloth](#)

2.2 *ISO Standard:*<sup>3</sup>

[ISO 9772 Cellular Plastics—Determination of Horizontal Burning Characteristics of Small Specimens Subjected to a Small Flame](#)

[ISO 13943 Fire Safety—Vocabulary](#)

## 3. Terminology

3.1 *Definitions:*

3.1.1 For definitions of terms relating to plastics, the definitions in this test method are in accordance with Terminology [D883](#). For terms relating to fire, the definitions in this test method are in accordance with Terminology [E176](#) and ISO 13943. In case of conflict, the definitions given in Terminology [E176](#) shall prevail. For terms relating to precision and bias and associated issues, the terms used in this test method are in accordance with the definitions in Terminology [E456](#).

3.2 *Definitions of Terms Specific to This Standard:*

3.2.1 *afterflame, n*—flame that persists after the ignition source has been removed.

<sup>1</sup> This test method is under the jurisdiction of ASTM Committee [D20](#) on Plastics and is the direct responsibility of Subcommittee [D20.30](#) on Thermal Properties.

Current edition approved May 1, 2022. Published May 2022. Originally approved in 1989. Last previous edition approved in 2020 as D4986 – 20. DOI: 10.1520/D4986-22.

<sup>2</sup> For referenced ASTM standards, visit the ASTM website, [www.astm.org](http://www.astm.org), or contact ASTM Customer Service at [service@astm.org](mailto:service@astm.org). For *Annual Book of ASTM Standards* volume information, refer to the standard's Document Summary page on the ASTM website.

<sup>3</sup> Available from American National Standards Institute (ANSI), 25 W. 43rd St., 4th Floor, New York, NY 10036, <http://www.ansi.org>.

\*A Summary of Changes section appears at the end of this standard

3.2.2 *afterflame time, n*—the length of time for which a material continues to flame, under specified conditions, after the ignition source has been removed.

3.2.3 *afterglow, n*—persistence of glowing combustion after both removal of the ignition source and the cessation of any flaming (Terminology E176).

3.2.4 *afterglow time, n*—the length of time for which a material continues to glow under specified test conditions, after the ignition source has been removed or cessation of flaming, or both.

3.2.5 *flame, v*—to undergo combustion in the gaseous phase with emission of light.

3.2.6 *glow, n*—visible light, other than from flaming, emitted by a solid undergoing combustion.

#### 4. Summary of Test Method

4.1 This test method for measuring the burning characteristics of cellular polymeric materials employs a small standard test specimen 50 by 150 mm. The specimen is supported horizontally. One end of the test specimen is exposed to a specified gas flame for 60 s. The test method is used to measure the burning rate, the extent of burning and the times for afterglow and afterflame.

#### 5. Significance and Use

5.1 This test method provides a means of measuring the time and extent of burning for cellular polymeric materials. It also provides a means of measuring burning rates for materials that continue to burn past the specified gage marks.

5.2 This test method provides a means of comparing the burning characteristics of materials of like thickness density, cell size, and skin irregularities, including the effect of falling particles of cellular polymeric materials. It is suitable for quality control, specification acceptance, and for research and development. Examples include filled or reinforced, rigid or flexible, or cut or formed materials

5.3 In this test method, the specimens are subjected to one or more specific sets of laboratory fire test exposure conditions. If different test conditions are substituted or if the anticipated

end-use conditions are changed, it is not always possible from this test method to predict changes in the performance characteristics measured. Therefore, the results are strictly valid only for the fire test exposure conditions described in this procedure.

5.4 This test method is not intended to be a criterion for fire hazard. The fire hazard created by materials depends upon the form and end use of the material. Assessment of fire hazard includes, but is not limited to, many factors such as flame spread, burning rate, ease of ignition, fuel contribution, heat evolution, products of combustion, and others.

#### 6. Apparatus

6.1 *Test Chamber*—A laboratory hood with a minimum capacity of 0.5 m<sup>3</sup>, free of induced or forced draft during testing. Use an enclosed laboratory hood with a heat-resistant glass window. If a draft is noted with the exhaust fan off, further measures are needed to eliminate the draft, such as adding a positive closing damper. The inside surfaces of the chamber shall be of a dark color. When a light meter, facing towards the rear of the chamber is positioned in place of the test specimen, the light level shall be less than 20 lx.

6.1.1 *Warning*—Products of combustion are toxic. An exhaust fan shall be provided for removing the products of combustion immediately after the test.

6.2 *Laboratory Burner*—Burner shall be constructed in accordance with Specification D5025.

6.3 *Wing Top*—Wing top made of copper or stainless steel, having an opening  $48 \pm 1$  mm in length by  $1.3 \pm 0.05$  mm in width fitted to the burner. (See Fig. 1 and Fig. 2.)

6.4 *Gas Supply*—Use technical-grade methane gas (min. 98 % pure) as the fuel with suitable regulator and meter for uniform gas flow.

6.4.1 The use of natural gas having an energy density of  $37 \pm 1$  MJ/m<sup>3</sup> has been found to provide similar results but is not acceptable as the referee gas in cases of dispute.

6.4.2 The use of other fuel gases such as butane, propane or acetylene is not suitable because they have higher energy per unit volume.

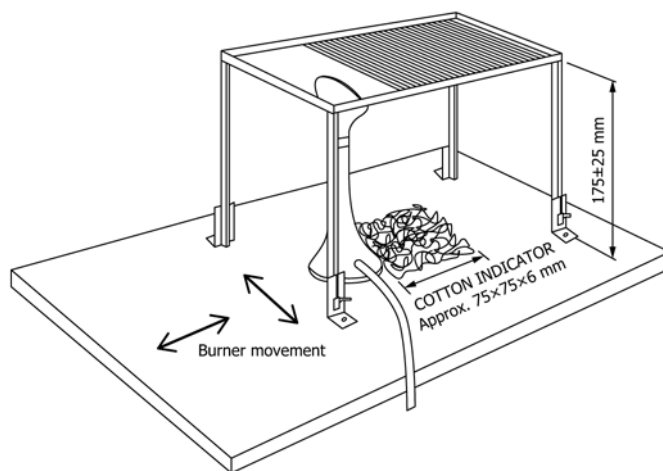

FIG. 1 Support Gauze Holder

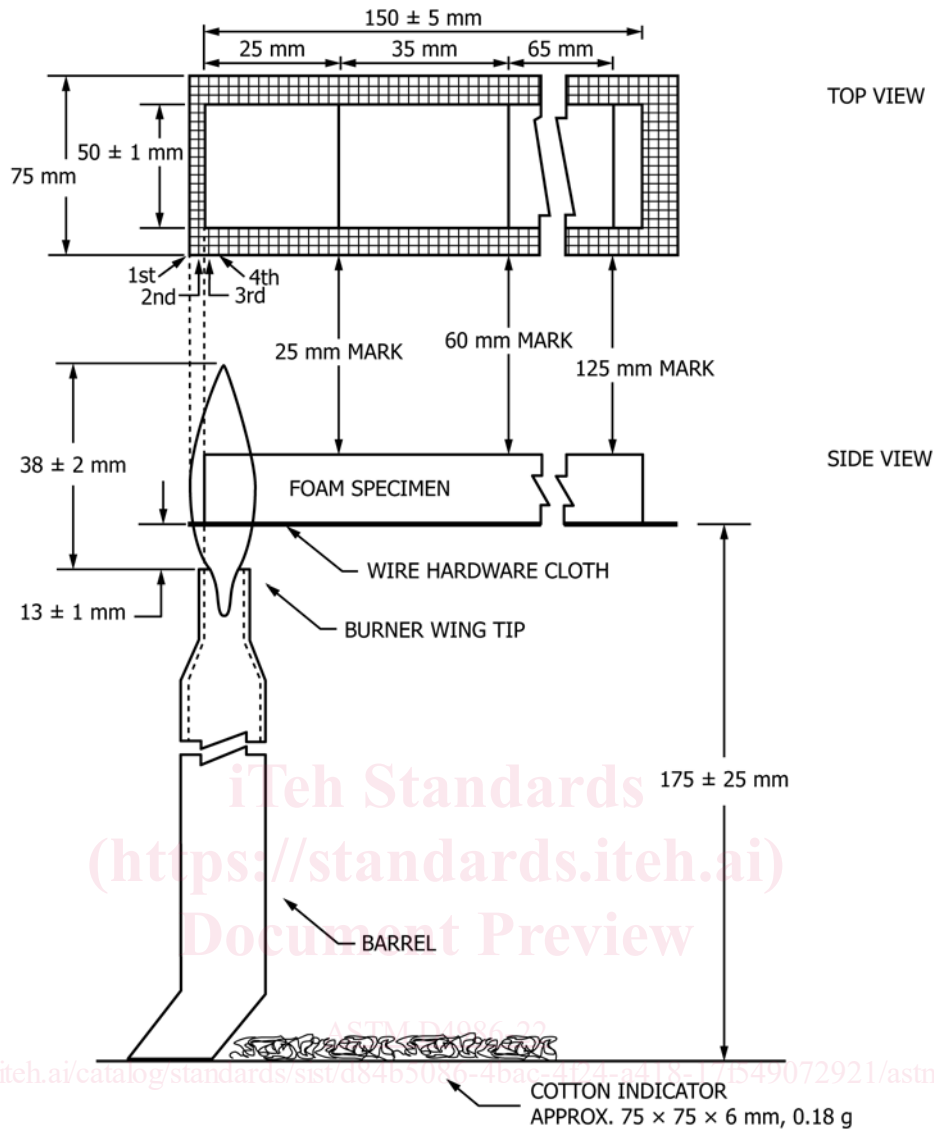

FIG. 2 Details of Flame and Relative Positions of Burner Wing Top, Test Specimen, and Specimen Support Gauze

6.5 *Wire Cloth*—Low-carbon, plain, steel wire, 6.4-mm mesh of  $0.90 \pm 0.05$ -mm wire diameter. The cloth mesh and wire diameter shall be determined in accordance with Specification E2016. The wire cloth shall be cut to approximately 215 by 75 mm. (See Fig. 1.)

6.6 *Support Fixture*—Any fixture that will support the wire cloth horizontally,  $13 \pm 1$  mm above the burner wing top and  $175 \pm 25$  mm above the base of the test chamber. Fig. 1 shows one acceptable arrangement.

6.7 *Timing Device(s)*—Stopwatch or other suitable timing device capable of timing to the nearest 0.5 seconds.

6.8 *Linear Measuring Device*—Graduated in millimeters.

6.9 *Cotton*—A supply of dry, absorbent 100 % surgical cotton.

6.10 *Desiccator*—Containing a suitable drying agent, capable of maintaining a relative humidity not exceeding 20 % at  $23 \pm 2^\circ\text{C}$ .

6.11 *Conditioning Room or Chamber*—Capable of being maintained at  $23 \pm 2^\circ\text{C}$  and a relative humidity of  $50 \pm 10$  %.

6.12 *Conditioning Oven*—A full-draft circulating air oven capable of being maintained at  $70 \pm 2^\circ\text{C}$ .

6.13 *Dial Gauge Micrometer*—As specified in Test Method D1622 or the applicable ASTM material specification.

## 7. Test Specimen

7.1 Since the results of tests carried out on test specimens of different colors, thicknesses, densities, molecular weights or containing different levels or amounts of additives are potentially different, the additional considerations indicated in 7.1.1 through 7.1.2 shall apply.

7.1.1 When conducting tests on test specimens at the minimum and maximum densities and melt flows, the test results shall only be considered representative of the complete range, if the results yield the same burning characteristics, including the same flame test classification.

7.1.2 If the burning characteristics, including the flame test classification, are not essentially the same for all specimens representing the range tested, the test results shall be considered to apply only to those materials for which the actual color, thickness, density, molecular mass and level of additives have been tested. Additional specimens shall be tested for intermediate ranges of each property.

7.2 The range of flammability characteristics is likely to be affected by the pigments and for each individual type of pigment, the flammability is likely to range between that corresponding to the highest level and that corresponding to no pigment. Testing as follows is required and is likely to cover the range of flammability performance:

- (a) contain no pigments (natural)
- (b) contain the highest level of organic pigments
- (c) contain the highest level of inorganic pigments
- (d) contain the highest level of carbon black (if carbon black is one of the additives in a pigment package)
- (e) contain pigments which are known to adversely affect flammability characteristics

7.3 All specimens shall be cut from a representative sample of the material. Care shall be taken to remove all dust and any particles from the surface.

7.4 The standard test specimen shall be  $150 \text{ mm} \pm 10 \text{ mm}$  long by  $50 \text{ mm} \pm 1 \text{ mm}$  wide.

7.4.1 Materials supplied in thicknesses over 13 mm shall be cut to  $13 \text{ mm} \pm 1 \text{ mm}$  thickness. If the material has a skin, remove material from only one side leaving the skin on the remaining surface.

7.4.2 Materials supplied in thicknesses of 13 mm or less shall be tested at the thickness supplied, without removing any material. (See 7.7.)

7.4.3 If materials with adhesive applied are to be tested, specimens having adhesive on one side only shall be used. (See 7.7.)

NOTE 2—Tests made on test specimens of different thicknesses, or directions of anisotropy are not comparable.

7.5 Prepare a minimum of 20 specimens for the test. This includes 10 additional specimens in the event that the situation described in X1.3 or X1.5 is encountered.

7.6 Mark each specimen across its width with lines at 25 mm, 60 mm and 125 mm from one end, referred to hereafter as gauge marks (see Fig. 2).

7.7 Test specimens with a high density exterior (skin) on one side shall be tested with this side facing down. Test specimens with adhesive on one side shall be tested with this side facing up.

## 8. Conditioning

8.1 Condition specimen sets as follows:

8.1.1 Condition one set of five specimens for at least 48 h at a temperature of  $23 \pm 2^\circ\text{C}$  and a relative humidity of  $50 \pm 10 \%$  prior to testing.

8.1.2 Condition a second set of five specimens in a circulating air oven for  $168 \pm 2 \text{ h}$  at  $70 \pm 2^\circ\text{C}$ , and then cool in a

desiccator capable of maintaining a relative humidity not exceeding 20 % at  $23 \pm 2^\circ\text{C}$  for at least 4 h at room temperature prior to testing.

8.2 All specimens shall be tested in a laboratory atmosphere of 15 to  $35^\circ\text{C}$  and  $<75 \%$  relative humidity.

8.3 Cotton shall be conditioned in the desiccator for at least 24 hours prior to use. Once removed from the desiccator, the cotton shall be used within 30 minutes.

## 9. Procedure

9.1 Conduct the burning test in a chamber, enclosure, or laboratory hood constructed in accordance with 6.1 and free of induced or forced draft.

9.2 Position the formed wire cloth in the support fixture so that the major section is horizontal. The bottom of the cloth shall be  $13 \pm 1 \text{ mm}$  above the burner wing top and 175 mm above the base of the test chamber. Place 0.18 g of cotton thinned to an area approximately 75 by 75 mm and a maximum thickness of 6 mm on the base of the test chamber. The cotton is to be located under the wire cloth such that it is below the front end of the specimen and extends at least up to 60 mm reference mark on the specimen.

9.3 The test specimen is to be placed flat on the wire cloth with the 150 by 50-mm surface horizontal. The end of the specimen closer to the 60-mm mark is to be placed on the wire cloth such that the edge of the specimen width is between the second and third vertical wire (from the left) of the rectangular wire cloth when the set-up is viewed from the top. (See Fig. 2.)

NOTE 3—To secure the position of the specimen on the wire cloth, stoppers may be used as references on the frame.

9.4 Adjust the methane gas supply to the burner to produce a gas flow rate of  $965 \pm 30 \text{ mL/min}$  with a back pressure of  $125 \pm 25 \text{ mm}$  water. Place the burner, with wing top, remote from the specimen, ignite, and adjust it to produce a blue flame  $38 \pm 2 \text{ mm}$  high. Adjust the gas supply, back pressure, and the air ports of the burner until a yellow-tipped blue flame is produced, and then increase the air supply until the yellow tip just disappears. Measure the height of the flame, and, if necessary, readjust to obtain a flame  $38 \pm 2 \text{ mm}$  high. The flame height measurement shall be made from the outside edges of the curved wing-tip.

9.5 Place the burner under the foam specimen so that the inner edge of the burner wing-tip is in line with the outer edge of the specimen. (See Fig. 2.) The center of the wing top is to be in line with the longitudinal axis of the specimen.

9.5.1 The burner movement needed for reapplication of flame shall be permitted to occur either in a direction parallel or in a direction perpendicular to the flame-application end of the specimen (See Fig. 1).

9.6 Start the timing device(s) when the test flame is applied. Remove the flame after 60 s. Record the times when the flame reaches the 25-mm, 60-mm, or 125-mm mark, when the specimen extinguishes.

9.7 If the specimen burns past the 125-mm mark, the time for the specimen to burn from the 25-mm mark to the 125-mm