



Designation: F18 – 12 (Reapproved 2022)

# Standard Specification and Test Method for Evaluation of Glass-to-Metal Headers Used in Electron Devices<sup>1</sup>

This standard is issued under the fixed designation F18; the number immediately following the designation indicates the year of original adoption or, in the case of revision, the year of last revision. A number in parentheses indicates the year of last reapproval. A superscript epsilon ( $\epsilon$ ) indicates an editorial change since the last revision or reapproval.

## 1. Scope

1.1 This specification and test method cover acceptance requirements for headers used in electron devices and describes procedures for determining conformance to these requirements.

1.2 The values stated in inch-pound units are to be regarded as standard. The values given in parentheses are mathematical conversions to SI units that are provided for information only and are not considered standard.

1.3 The following safety hazard caveat pertains only to the test method (Sections 7 – 13) described in this specification. *This standard does not purport to address all of the safety concerns, if any, associated with its use. It is the responsibility of the user of this standard to establish appropriate safety, health, and environmental practices and determine the applicability of regulatory limitations prior to use.*

1.4 *This international standard was developed in accordance with internationally recognized principles on standardization established in the Decision on Principles for the Development of International Standards, Guides and Recommendations issued by the World Trade Organization Technical Barriers to Trade (TBT) Committee.*

## 2. Terminology

### 2.1 Definitions of Terms Specific to This Standard:

2.1.1 The header may be described as an external metal member of cylindrical, oval, or other shape into which is sealed one or more wire leads or metal tubulations through a glass medium. The metal parts may be plated or unplated and the glass may be clear or opaque.

## 3. Significance and Use

3.1 This standard covers procedures for conducting mechanical and vacuum leak tests on glass-to-metal headers and is suitable for quality control and research and development use.

<sup>1</sup> This specification and test method are under the jurisdiction of ASTM Committee F01 on Electronics and are the direct responsibility of Subcommittee F01.03 on Metallic Materials, Wire Bonding, and Flip Chip.

Current edition approved May 1, 2022. Published May 2022. Originally approved in 1961 as F18 – 61 T. Last previous edition approved in 2017 as F18 – 12 (2017). DOI: 10.1520/F0018-12R22.

3.2 This standard is suitable for assessing both the quality of materials as well as the manufacturing techniques used.

## 4. Acceptance Requirements

4.1 The headers shall conform to the requirements as specified in 4.1.1 and 4.1.2 when tested in accordance with the prescribed methods of test (Sections 5 – 13).

### 4.1.1 Visual:

4.1.1.1 Cracks around the lead shall be restricted axially and radially to one lead diameter. Specimens showing any other type of crack shall be rejected.

4.1.1.2 The glass shall be free of inclusions exceeding one half of the smallest lead diameter. Gas bubbles entirely enclosed by glass are permissible up to a diameter not exceeding that of the smallest lead.

4.1.1.3 Metallic parts shall be as free of draw lines or grooves longer (by visual estimate) than one half of the seal length as best commercial practice will permit.

4.1.1.4 In the case of clear glass seals, reference is made to the seal area only.

4.1.1.5 In the case of opaque glass seals, reference is made to any portion of the exposed metal parts.

### 4.1.2 Leak:

4.1.2.1 With the header sealed to the mass spectrometer leak detector, the number of detectable leaks in a sample lot shall be less than the limit agreed upon between the purchaser and the seller.

## TEST METHODS

## 5. Apparatus

5.1 *Microscope*, of 10 power magnification, unless otherwise specified, in combination with suitable incandescent white light source.

5.2 *Mass Spectrometer Leak Detector*, adjusted to respond to a tracer gas such as helium and capable of detecting leaks of  $10^{-9}$  mL/s at standard temperature and pressure.

5.3 *Hood*, having a volume of approximately  $250 \text{ cm}^3$  ( $2.5 \times 10^{-4} \text{ m}^3$ ), to cover the test specimen completely with the tracer gas. (The hood should be flushed with the tracer gas for at least 10 s).

5.4 *Fixture*, suitable for making a seal between the header under test and the leak detector. A suggested jig is shown in Fig. 1.

5.5 *Bath*, two constant temperature water baths, and an immersion bath maintained at a temperature of  $-80^{\circ}\text{C}$  to  $-70^{\circ}\text{C}$ .

5.6 *Torque Fixture*, capable of holding the header in a fixed position and capable of rotating a lead about its axis.

5.7 *Bending Fixture*, capable of rotating the header through an arc of  $90, +0 - 5^{\circ}$ , about an axis of the lead under test and through the exit point of the lead from the glass. A weight is attached to the lead at a point close to the extremity.

5.8 *Megohmmeter*, for testing electric insulation.

5.9 *Furnace*, capable of heating parts to a temperature of  $450^{\circ}\text{C}$  maximum.

5.10 *Lead Pull Tester*, capable of holding the header in a fixed position while applying a load along the axis of the lead in a direction perpendicular to the plane containing the rim of the header. The displacement of one constraining member of the tester shall increase at a constant rate with respect to the second constraining member of the tester.

6. Conditions of Test

6.1 Tests shall be made in the order indicated in Sections 7 – 13, and on individual specimens unless otherwise specified. Each test shall be performed with the apparatus described in the corresponding paragraph of Section 5. Tests on leads shall be made on portion of the lead external to the finished device

unless otherwise specified. Lead dimensions referred to are nominal dimensions agreed upon between the purchaser and the seller.

7. Thermal Shock

7.1 With the header at room temperature immerse it in water held at  $98^{\circ}\text{C}$ , minimum, for 1 min; and quench in water at  $1^{\circ}\text{C}$ , maximum, for 1 min. The volume of the water bath shall be large enough to prevent appreciable change in temperature upon immersion of the header. Repeat this cycle 6 times. Then bake the header in the furnace at  $100 \pm 5^{\circ}\text{C}$  and under a vacuum of less than  $10^{-3}$  torr ( $1.33 \times 10^{-4}$  kPa) for a minimum of 12 h. The headers shall conform to the requirements specified in 4.1.

8. Torque

8.1 *Leads Less than 0.021 in. (0.53 mm) in Diameter*—Clamp the lead to be tested between 2 and 4 diameters away from the glass. With the header fixed, rotate the lead through  $1080 \pm 30^{\circ}$  (3 complete revolutions) about its own axis at a uniform rate of 10 to 20 r/min. After completion of the test, the header shall conform to the requirements specified in 4.1.

8.2 *Leads or Terminals Greater than 0.021 in. (0.53 mm) in Diameter*—To the outer portion of the terminal at a point between 2 and 4 terminal diameters away from the glass, slowly apply a torque of at least 250 lbf-in./(.in. of lead diameter)<sup>2</sup> or  $(0.0438 \text{ N}\cdot\text{m}/(\text{mm of lead diameter})^2)$  as calculated using the nomograph shown in Fig. 2. The header shall conform to the requirement specified in 4.1.

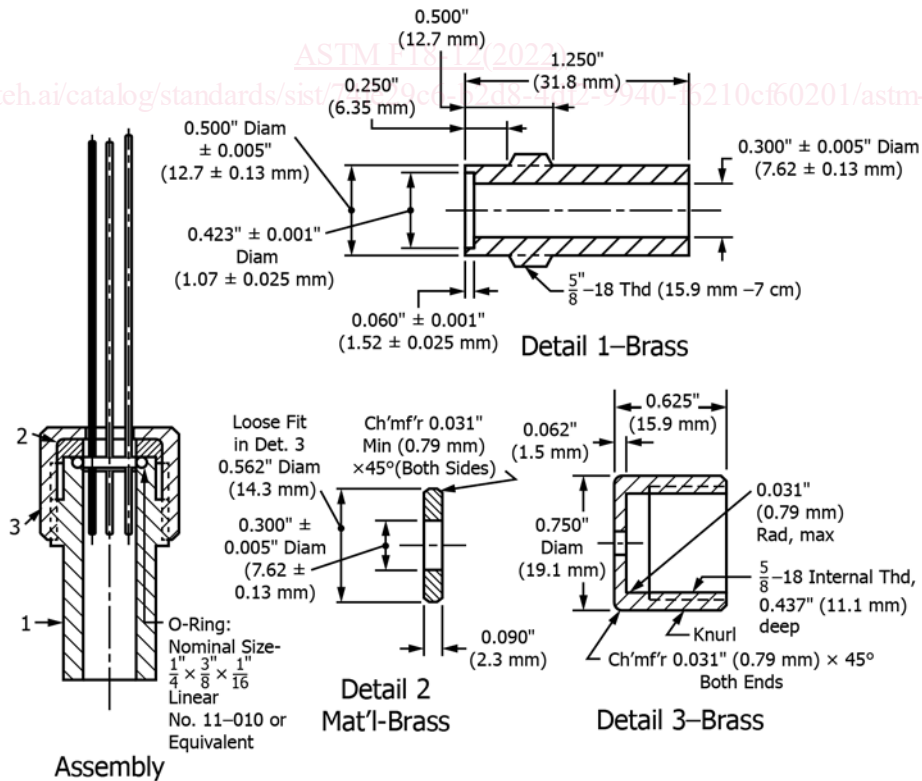
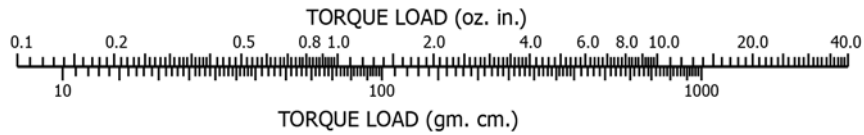

FIG. 1 Fixture for Making a Seal Between the Header Under Test and the Leak Detector



⊙

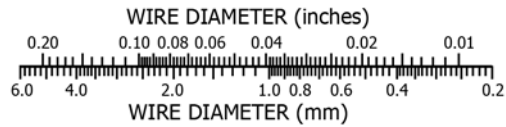

FIG. 2 Nomograph of Torque Loads for Various Wire Diameters

**9. Lead Fatigue**

9.1 Attach to the flexible lead a weight computed from the following equations: For Fe-Ni-Co, Dumet, and Ni-Fe alloys (Fig. 3):

$$55,000 \times (\text{diameter of lead in in.})^2 = \text{oz}$$

or

$$2.4 \times (\text{diameter of lead in mm})^2 = \text{kg}$$

For Fe-Ni-Co clad copper (Fig. 4):

$$23,000 \times (\text{diameter of lead in in.})^2 = \text{oz}$$

or

$$1.2 \times (\text{diameter of lead in mm})^2 = \text{kg}$$

The weighted lead shall be capable of being bent through 5 cycles at a rate of 15 to 20 cycles per minute without breaking. One cycle consists of a rotation of the header from  $0 \pm 5^\circ$  (from the normal position) to  $90 + 0 - 5^\circ$  and returning to  $0 \pm 5^\circ$ .

**10. Electrical Leakage**

10.1 The d-c resistance as measured between any two metal members shall be greater than 1000 MΩ. Perform this measurement at a temperature of  $25 \pm 5^\circ\text{C}$  and a relative humidity of  $45 \pm 10\%$ . Apply a voltage of at least 500 V dc. The method of cleaning the headers prior to this test shall be as agreed upon by the purchaser and the seller.



⊙

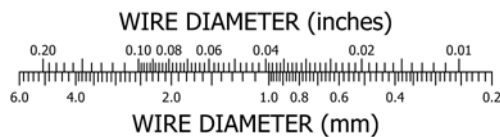

FIG. 3 Nomograph of Weights for Lead Fatigue Test of Fe-Ni-Co, Dumet, and Ni-Fe Alloys