



Designation: ~~E3311/E3311M – 21~~ E3311/E3311M – 22

~~Standard Test Method for Evaluating Response Robot Mobility Using Variable Diagonal Rail Obstacles~~ Ground Robot Capabilities and Remote Operator Proficiency: Obstacles: Variable Height Rails¹

This standard is issued under the fixed designation E3311/E3311M; the number immediately following the designation indicates the year of original adoption or, in the case of revision, the year of last revision. A number in parentheses indicates the year of last reapproval. A superscript epsilon (ϵ) indicates an editorial change since the last revision or reapproval.

INTRODUCTION

The robotics community needs ways to measure whether a particular robot is capable of performing specific missions in complex, unstructured, and often hazardous, environments. These missions require various combinations of elemental robot capabilities. Each capability can be represented as a test method with an associated apparatus to provide tangible challenges for various mission requirements and performance metrics to communicate results. These test methods can then be combined and sequenced to evaluate essential robot capabilities and remote operator proficiencies necessary to successfully perform intended missions.

The ASTM International Standards Committee on Homeland Security Applications (E54) specifies these standard test methods to facilitate comparisons across different testing locations and dates for diverse robot sizes and configurations. These standards support robot researchers, manufacturers, and user organizations in different ways. Researchers use the standards to understand mission requirements, encourage innovation, and demonstrate break-through capabilities. Manufacturers use the standards to evaluate design decisions, integrate emerging technologies, and harden systems. Emergency responders and soldiers use them to guide purchasing decisions, align deployment expectations, and focus training with standard measures of operator proficiency. Associated usage guides describe how these standards can be applied to support various objectives.

Several suites of standards address these elemental capabilities including maneuvering, mobility, dexterity, sensing, energy, communications, durability, proficiency, autonomy, and logistics. This standard is part of the ~~Mobility~~Obstacles suite of test methods.

1. Scope

1.1 This test method is intended for remotely operated ground robots operating in complex, unstructured, and often hazardous environments. It specifies the apparatuses, procedures, and performance metrics necessary to measure the capability of a robot to negotiate an obstacle in the form of variable ~~diagonal~~height rail. This test method is one of several related ~~mobility~~obstacle tests that can be used to evaluate overall system capabilities.

1.2 The robotic system includes a remote operator in control of most functionality, so an onboard camera and remote operator

¹ This test method is under the jurisdiction of ASTM Committee E54 on Homeland Security Applications and is the direct responsibility of Subcommittee E54.09 on Response Robots.

Current edition approved Nov. 15, 2021; May 1, 2022. Published December 2021; May 2022. Originally approved in 2021. Last previous edition approved in 2021 as E3311/E3311M – 21. DOI: ~~10.1520/E3311-E3311M-21~~10.1520/E3311_E3311M-22.

display are typically required. This test method can be used to evaluate assistive or autonomous behaviors intended to improve the effectiveness or efficiency of remotely operated systems.

1.3 Different user communities can set their own thresholds of acceptable performance within this test method for various mission requirements.

1.4 *Performing Location*—This test method may be performed anywhere the specified apparatuses and environmental conditions can be implemented.

1.5 *Units*—The International System of Units (a.k.a. SI Units) and U.S. Customary Units (a.k.a. Imperial Units) are used throughout this document. They are not mathematical conversions. Rather, they are approximate equivalents in each system of units to enable use of readily available materials in different countries. The differences between the stated dimensions in each system of units are insignificant for the purposes of comparing test method results, so each system of units is separately considered standard within this test method.

1.6 *This standard does not purport to address all of the safety concerns, if any, associated with its use. It is the responsibility of the user of this standard to establish appropriate safety, health, and environmental practices and determine the applicability of regulatory limitations prior to use.*

1.7 *This international standard was developed in accordance with internationally recognized principles on standardization established in the Decision on Principles for the Development of International Standards, Guides and Recommendations issued by the World Trade Organization Technical Barriers to Trade (TBT) Committee.*

2. Referenced Documents

2.1 ASTM Standards:²

[E2521 Terminology for Evaluating Response Robot Capabilities](#)

[E2592 Practice for Evaluating Response Robot Capabilities: Logistics: Packaging for Urban Search and Rescue Task Force Equipment Caches](#)

2.2 Other Standard:

[NIST Special Publication 1011–I–2.0 Autonomy Levels for Unmanned Systems \(ALFUS\) Framework, Volume 1: Terminology, Version 2.04³](#)

3. Terminology

3.1 *Definitions*—The following terms are used in this test method and are defined in Terminology [E2521](#): *abstain, administrator or test administrator, emergency response robot or response robot, fault condition, operator, operator station, remote control, repetition, robot, teleoperation, test event or event, test form, test sponsor, test suite, testing target or target, testing task or task, and trial or test trial.*

3.2 The following terms are used in this test method and are defined in ALFUS Framework Volume I:3: *autonomous, autonomy, level of autonomy, operator control unit (OCU), and semi-autonomous.*

3.3 *Definitions of Terms Specific to This Standard:*

3.3.1 *apparatus clearance width (W)_n*—a specification for the apparatus dimensions chosen from one of four possible measurements, based on the intended robot deployment environment:

240 cm ± 2.5 cm tolerance [96 in. ± 1 in. tolerance], such as open and outdoor public spaces;

120 cm ± 2.5 cm tolerance [48 in. ± 1 in. tolerance], such as indoor spaces in accessibility-compliant buildings;

60 cm ± 1.3 cm tolerance [24 in. ± 0.5 in. tolerance], residences and aisles of public transportation; or

30 cm ± 1.3 cm tolerance [12 in. ± 0.5 in. tolerance], cluttered indoor spaces, ductwork, and voids in collapsed structures.

3.3.1.1 *Discussion*—

The measures for these scales are nominal and do not represent the measurement of the narrowest point in the apparatus through which the robot should pass. Consult the Section 6 (Apparatus) for the overall measurements and dimensions of the apparatus at each scale.

² For referenced ASTM standards, visit the ASTM website, www.astm.org, or contact ASTM Customer Service at service@astm.org. For *Annual Book of ASTM Standards* volume information, refer to the standard's Document Summary page on the ASTM website.

³ Available from National Institute of Standards and Technology (NIST), 100 Bureau Dr., Stop 1070, Gaithersburg, MD 20899-1070, <http://www.nist.gov>.

3.3.2 *subfloor, n*—an underlayment of OSB or similar material with dimensional lumber borders used to affix multiple subfloors to one another and can contain apparatus elements, such as terrains or obstacles.

3.3.3 *variable diagonalheight rail, n*—a solid piece of dimensional lumber that is sized to fit inside a subfloor at a 45° angle.

4. Summary of Test Method

4.1 This test method is performed by a remote operator that cannot see or hear the operator, out of sight and sound of the robot, while controlling the robot within the test apparatus. The robot traverses through a defined area to negotiate the variable diagonalheight rail obstacle with or without walls for confinement (see Fig. 1). This test method requires the robot to overcome challenges such as pitch, roll, traction, and control of variable chassis shape and articulators.

4.2 The robot traverses a path as shown in Fig. 1. The robot starts on the A-side of the apparatus, crosses to the B-side into the nearest approach area, traverses over the variable diagonalheight rail obstacle to the exit area on the opposite end of the apparatus, and then crosses to the A-side to complete each repetition. All repetitions alternate directions through the apparatus.

4.3 The robot traverses the path in one of two operationally-relevant driving orientations: *unrestricted* or *forward/reverse*. *Unrestricted* allows the robot to traverse the path in any driving orientation throughout the test. *Forward/reverse* requires the robot to alternate, for each repetition, driving in forward and reverse. As repetitions also alternate directions through the apparatus, this means that the robot shall not rotate between ending one repetition and starting the next. Resulting data from the two driving orientations are not comparable to one another.

4.4 There are three apparatus configurations: *open, rectangular confinement*, and *square confinement*. In the *open* configuration, no walls are used around the approach/exit areas. The open configuration is representative of operating in unobstructed areas. The *rectangular confinement* and *square confinement* configurations use walls around the approach/exit areas. The walls are used to define the robot's path and are representative of operating in a confined environment. The square configuration has half of the available area as the rectangular configuration.

4.5 *Potential Faults Include:*

4.5.1 Any contact by the robot with the apparatus that requires adjustment or repair to return the apparatus to the initial condition; and

4.5.2 Any visual, audible, or physical interaction that assists either the robot or the remote operator.

4.6 Test trials shall produce enough successful repetitions to demonstrate the reliability of the system capabilities testing requires

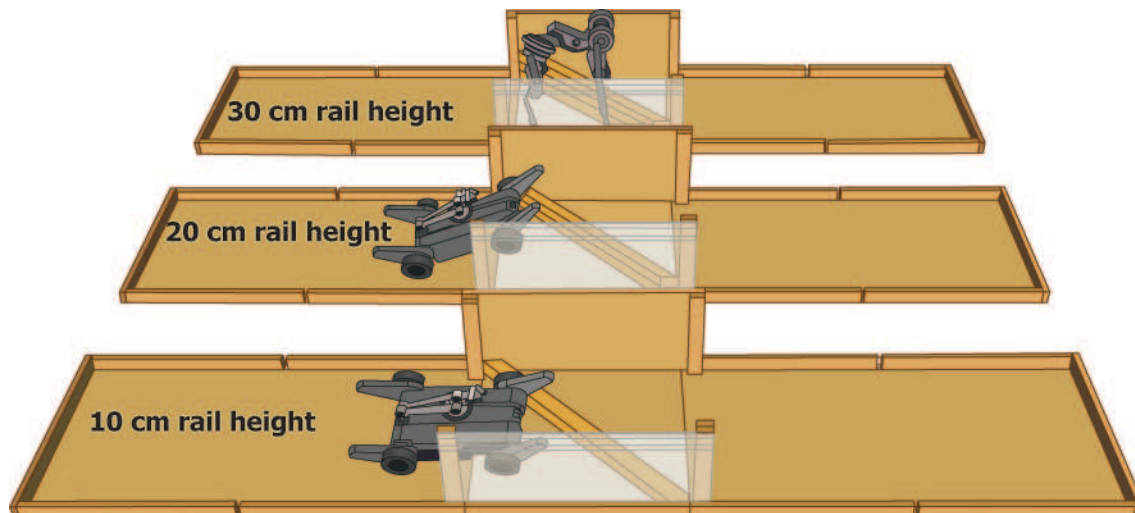

FIG. 1 (A) View of the Variable DiagonalHeight Rail; Shown Heights; Heights: 10 cm [4 in.], 20 cm [8 in.], 30 cm [12 in.]

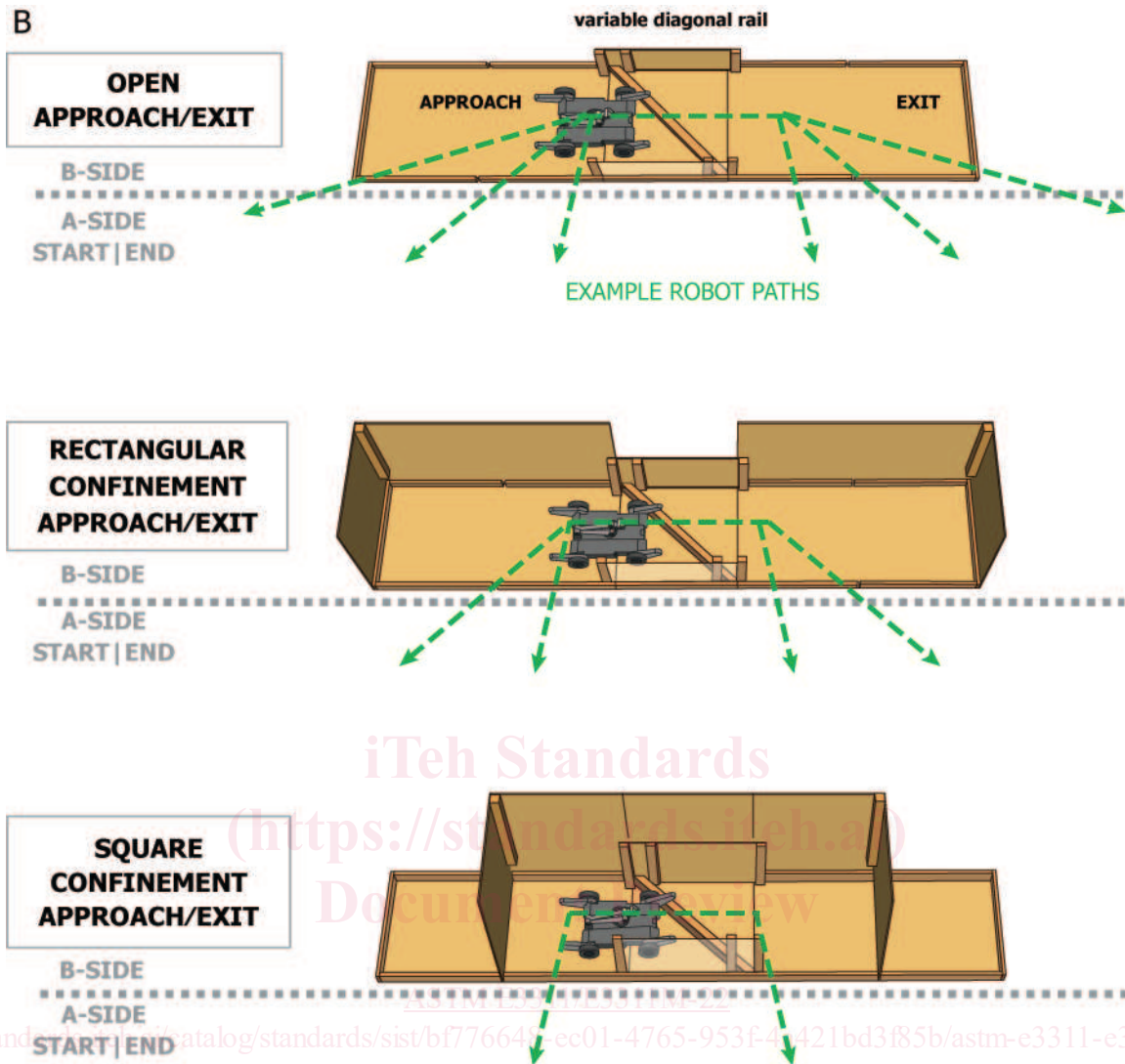

FIG. 1 (B) View of the Variable Diagonal Height Rail Showing the Open, Rectangular, and Square Confinement Approach/exit Areas and Example Robot Traversal Paths (continued)

capability or the remote operator proficiency to the desired level of statistical significance (see Section 9 enough time for an expert operator to-). A complete trial of 10 to 30 repetitions should take 10 to 30 min to complete. When measuring system capabilities, it is important to allow enough time to capture a complete trial with an expert operator. When measuring operator proficiency, it is important to limit the time of the trial so that expert operators have ample time to perform a statistically significant set of repetitions, which is typically 10 to 30 repetitions. The total number of repetitions to perform is based on the desired percent of reliability and confidence in the results. repetitions while novice operators are not excessively fatigued. There are three metrics to consider when calculating the results of a test trial. They should be considered in the following order of importance: completeness score, reliability, and efficiency. The results from open, rectangular confinement, and square confinement configurations are not comparable because they represent different difficulties and clearances.

4.6.1 The resulting rate of successful repetitions can be directly compared to the resulting rate of any other trial no matter the duration of each trial. The average rate is equal to the number of successful repetitions divided by the elapsed time of the trial. The average rate is expressed in repetitions per minute.

4.6.2 Time limited trials can be used to evaluate system capabilities or operator proficiency, or both, when a more tightly scheduled test plan is necessary. Time limited trials can also reduce excessive fatigue for novices that typically take longer to complete the tasks while learning. Time limited trials should be long enough to enable proficient operators to perform at least 10 successful repetitions to establish their reliability with some level of confidence. The resulting average rate of success is comparable with trials of different durations. Time limited trials of equal duration can always be compared directly to one another using the number of successfully completed repetitions.

4.6.3 There are three metrics to consider when calculating the results of a test trial. They should be considered in the following order of importance: completeness score, reliability, and efficiency. The results from open, rectangular confinement, and square confinement configurations are not comparable because they represent different difficulties and clearances.

5. Significance and Use

5.1 This test method is part of an overall suite of related test methods that provide repeatable measures of robotic system mobility and remote operator proficiency. The variable diagonalheight rail obstacle challenges robotic system locomotion, suspension systems to maintain traction, rollover tendencies, high-centering tendencies, self-righting (if necessary), chassis shape variability (if available), and remote situational awareness by the operator. As such, the variable diagonalheight rail obstacle can be used to represent obstacles in the environment, such as railroad tracks, curbs, and debris.

5.2 The scale of the apparatus can vary to provide different constraints representative of typical obstacle spacing in the intended deployment environment. For example, the three configurations can be representative of repeatable complexity for unobstructed obstacles (open configuration), relatively open parking lots with spaces between cars (rectangular confinement configuration), or within bus, train, or plane aisles, or dwellings with hallways and doorways (square confinement configuration).

5.3 The test apparatuses are low cost and easy to fabricate so they can be widely replicated. The procedure is also simple to conduct. This eases comparisons across various testing locations and dates to determine best-in-class systems and operators.

5.4 *Evaluation*—This test method can be used in a controlled environment to measure baseline capabilities. The variable diagonalheight rail obstacle can also be embedded into operational training scenarios to measure degradation due to uncontrolled variables in lighting, weather, radio communications, GPS accuracy, etc.

5.5 *Procurement*—This test method can be used to identify inherent capability trade-offs in systems, make informed purchasing decisions, and verify performance during acceptance testing. This aligns requirement specifications and user expectations with existing capability limits.

5.6 *Training*—This test method can be used to focus operator training as a repeatable practice task or as an embedded task within training scenarios. The resulting measures of remote operator proficiency enable tracking of perishable skills over time, along with comparisons of performance across squads, regions, or national averages.

<https://standards.iteh.ai/catalog/standards/sist/bf776648-ec01-4765-953f-4a421bd3f85b/astm-e3311-e3311m-22>

5.7 *Innovation*—This test method can be used to inspire technical innovation, demonstrate break-through capabilities, and measure the reliability of systems performing specific tasks within an overall mission sequence. Combining or sequencing multiple test methods can guide manufacturers toward implementing the combinations of capabilities necessary to perform essential mission tasks.

6. Apparatus

6.1 The apparatus consists of subfloors, walls (only for rectangular confinement and square confinement configurations), and the variable diagonalheight rail obstacle (see Fig. 2). The main apparatus dimension to consider is the minimumapparatus clearance width (W) for the robot. The minimum clearance width should be chosen to robot, which can be set to 240 cm [96 in.] with ± 2.5 cm [1 in.] tolerance, 120 cm [48 in.] with ± 2.5 cm [1 in.] tolerance, 60 cm [24 in.] with ± 1.3 cm [0.5 in.] tolerance, or 30 cm [12 in.] with ± 1.3 cm [0.5 in.] tolerance. The dimension chosen for W should represent the intended deployment environment or should be based on the size of the robot, or both. The minimum clearance width is typically set to 120 cm [4 ft], 60 cm [2 ft], or 30 cm [1 ft] to efficiently use available construction materials, although other apparatus sizes can be used both, (that is, the robot shall be able to maneuver within the selected dimensions of the apparatus). All apparatus dimensions scale proportionally with W (see Fig. 3). All apparatus dimensions scale proportionally with the minimum clearance width (see and Fig. 4). For example, the width of the variable diagonalheight rail obstacle apparatus is 1W, and the length of the variable diagonalheight rail obstacle apparatus is either 3W (square confinement configuration) or 5W (rectangular confinement and open configurations). The equipment required to perform this test method includes the apparatus and a timer. Resulting data from a specific minimum clearance width of the apparatus is not comparable to data from other apparatuses with different minimum clearance widths.

6.2 The apparatus consists of two symmetrical approach/exit areas on either side of a variable diagonalheight rail obstacle. There are three configurations of the apparatus: open, rectangular confinement, and square confinement (see Fig. 3). The selection of

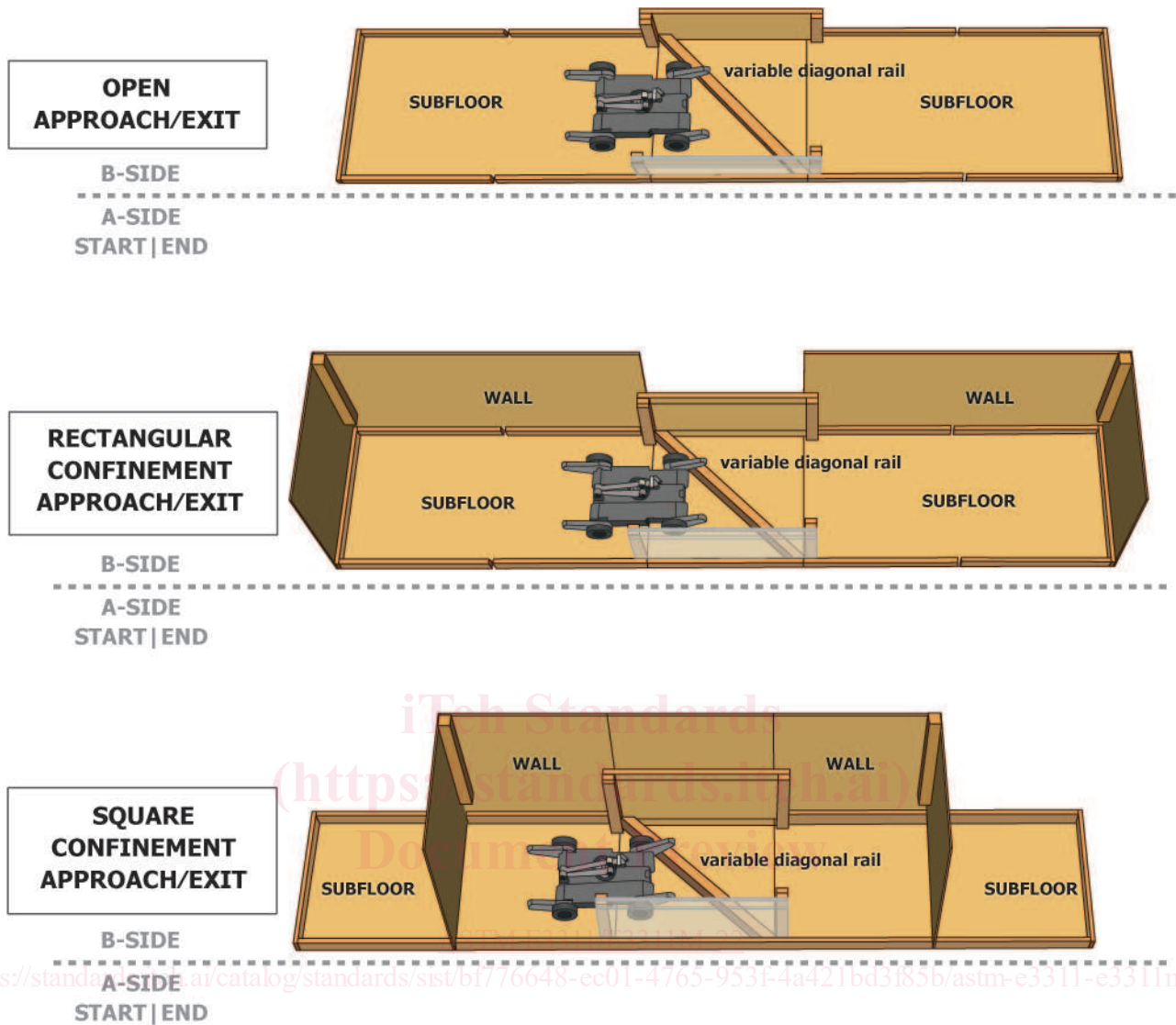

FIG. 2 View of a Test Apparatus with Labeled Components

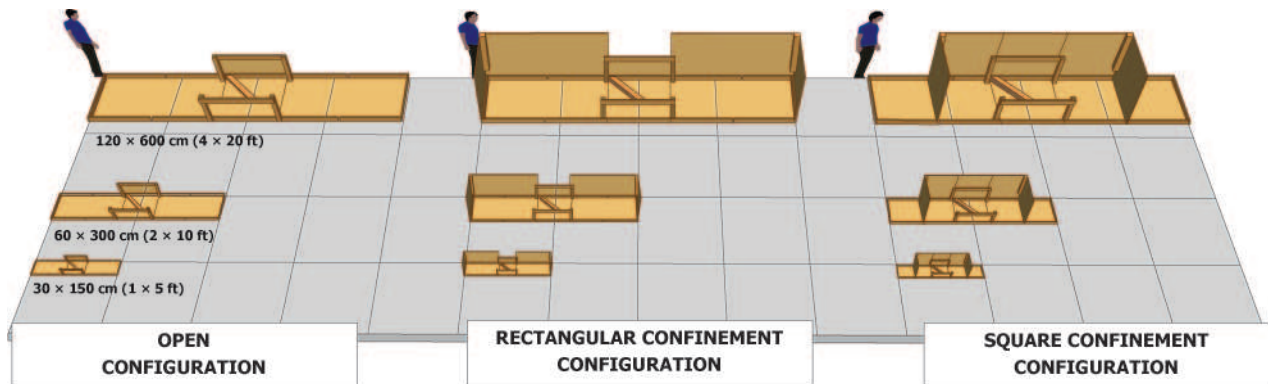

FIG. 3 Testing Apparatus is Scalable to Represent Different Environments

apparatus configuration should correspond to intended deployment environment. The open configuration does not use walls in the approach areas on either side of the variable diagonal rail obstacle, allowing for unobstructed robot movement. The approach areas in the rectangular confinement configuration measure 2W by 1W and are bounded by walls taller than the robot to obstruct robot movement. The approach areas in the square confinement configuration measure 1W by 1W and are bounded by walls taller

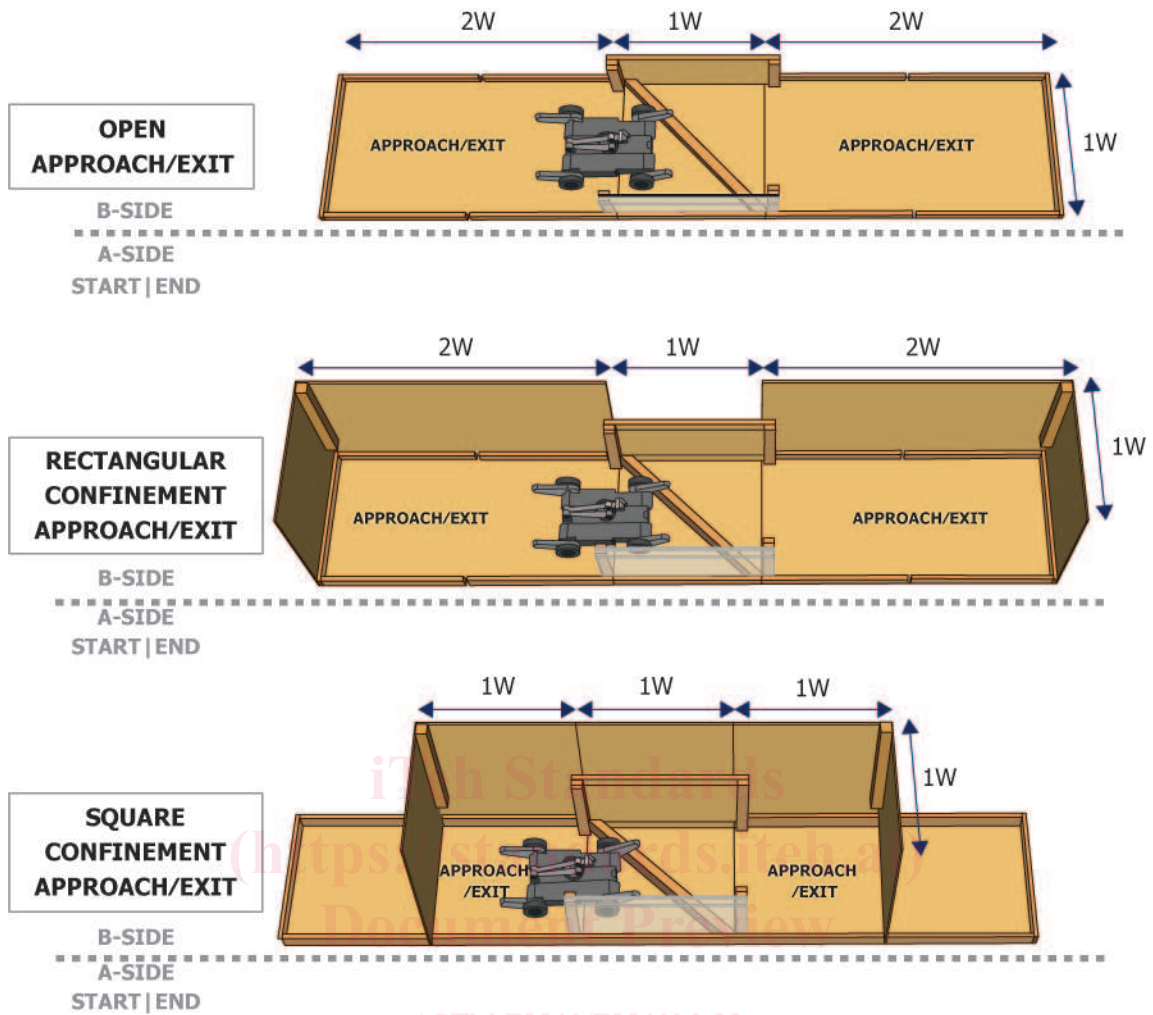

FIG. 4 Top View of a Test Apparatus Showing the Dimensions and Labeled Open, Rectangular Confinement, and Square Confinement Approach/exit Areas

than the robot to further obstruct robot movement. Resulting data from a specific configuration of the apparatus is not comparable to data from other apparatuses with different configurations.

6.3 *Variable Diagonal Height Rail*—The variable diagonal height rail obstacle is constructed of one or more pieces of dimensional lumber attached to the top of the subfloor at a 45° angle. The variable diagonal height rail is contained within a 1W length of the apparatus (see Fig. 5). The thickness of the variable diagonal height rail is relative to the scale of the apparatus (see Table 1). The overall height of the variable diagonal height rail is adjustable by stacking multiple pieces of dimensional lumber on top of each other. (See Fig. 5.) Due to variations in dimensional lumber it may be necessary to include additional lumber to ensure proper overall height of the variable diagonal rail.

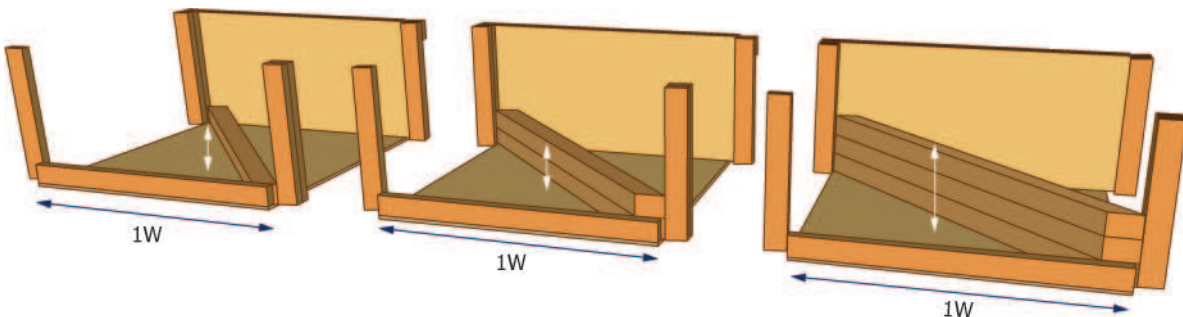

FIG. 5 View of the Apparatus Showing Dimensions of the Variable Diagonal Height Rail