



Designation: C367/C367M – 22

Standard Test Methods for Strength Properties of Prefabricated Architectural Acoustical Tile or Lay-In Ceiling Panels¹

This standard is issued under the fixed designation C367/C367M; the number immediately following the designation indicates the year of original adoption or, in the case of revision, the year of last revision. A number in parentheses indicates the year of last reapproval. A superscript epsilon (ϵ) indicates an editorial change since the last revision or reapproval.

INTRODUCTION

Materials used for absorbing sound generally have a porous, low-density structure. In comparison with many building materials they are relatively fragile. Materials are available that possess adequate strength and stability and at the same time provide good sound absorption. The test methods described here cover procedures for evaluating those physical properties related to strength. The methods are of use in developing, manufacturing, and selecting acoustical tile or lay-in panels.

Keep in mind that a property related to strength is only one of several considerations important in judging the usefulness of an acoustical material. For example, a material judged to be quite weak by one of these tests is still desired for other reasons, and with adequate precautions, is shipped and installed successfully.

1. Scope

1.1 These test methods cover the determination of the strength properties of prefabricated architectural acoustical tile or lay-in ceiling panels as follows:

Tests	Sections
Hardness	4 to 9
Friability	10 to 16
Sag	17 to 23
Transverse strength	24 to 30

1.2 Not all of the tests described in these test methods are necessary to evaluate any particular product for a specific use. In each instance, it is necessary to determine which properties are required.

1.3 These test methods specify procedures that are used in product development, manufacturing control, specification acceptance, and service evaluation.

1.4 Properties determined by these test methods reflect the performance of the materials under the specific conditions of the test, and do not necessarily indicate performance under conditions other than those specified herein.

1.5 The values stated in either SI units or inch-pound units are to be regarded separately as standard. The values stated in each system are not exact equivalents; therefore, each system

shall be used independently of the other. Combining values from the two systems will result in non-conformance with the standard.

1.6 *This standard does not purport to address all of the safety concerns, if any, associated with its use. It is the responsibility of the user of this standard to establish appropriate safety, health, and environmental practices and determine the applicability of regulatory limitations prior to use.*

1.7 *This international standard was developed in accordance with internationally recognized principles on standardization established in the Decision on Principles for the Development of International Standards, Guides and Recommendations issued by the World Trade Organization Technical Barriers to Trade (TBT) Committee.*

2. Referenced Documents

2.1 *ASTM Standards*²
[C634 Terminology Relating to Building and Environmental Acoustics](#)

3. Terminology

3.1 Terms used in this standard are defined either in Terminology C634 or within this standard. The definition of terms explicitly given within this standard take precedence over definitions given in Terminology C634. The definitions within

¹ These test methods are under the jurisdiction of ASTM Committee E33 on Building and Environmental Acoustics and are the direct responsibility of Subcommittee E33.04 on Application of Acoustical Materials and Systems.

Current edition approved May 15, 2022. Published May 2022. Originally approved in 1955. Last previous edition approved in 2021 as C367/C367M – 16 (2021). DOI: 10.1520/C0367_C0367M-22.

² For referenced ASTM standards, visit the ASTM website, www.astm.org, or contact ASTM Customer Service at service@astm.org. For *Annual Book of ASTM Standards* volume information, refer to the standard's Document Summary page on the ASTM website.

Terminology **C634** and this standard take precedence over any other definitions of defined terms found in any other documents, including other documents that may be referenced in this standard.

3.2 Definitions of Terms Specific to This Standard:

3.2.1 *fissures, n*—irregular depressions of varying lengths widths, and depths extending below the basic product face.

3.2.2 *friable, adj*—easily crumbled.

3.2.3 *sag, n*—deviation of the acoustical tile or panel at its geometric center from the plane formed by the edges.

HARDNESS

4. Significance and Use

4.1 Knowledge of hardness is useful in the development and the quality control of acoustical tile and lay-in ceiling panels. Deviation from an established hardness range will assist in pointing out processing errors or defective raw materials, thereby aiding the maintenance of uniform product quality.

4.2 This property is also useful in comparing the relative abilities of materials to resist indentations on the panel surface caused by impacts.

4.3 Since the hardness varies with the thickness, only samples of the same thickness shall be directly compared.

5. Apparatus

5.1 *Testing Machine*—Any standard mechanical or hydraulic testing machine capable of applying and measuring the required load within an accuracy of $\pm 1\%$ shall be used. It shall be equipped with a 2.00 in. [50.8 mm] diameter metal ball, or hemispherically shaped penetrator that bears upon the specimen surface.

6. Test Specimens

6.1 Cut five 4 by 4 in. [100 by 100 mm] specimens from a single tile or panel. Cut the five specimens from representative areas of the tile or ceiling panel.

7. Conditioning

7.1 The strength properties of acoustical materials often depend on the moisture content at the time of the test. Therefore, condition materials for test under “room conditions” to constant weight (within $\pm 1\%$) in an atmosphere maintained at a relative humidity of $50 \pm 2\%$, and a temperature of $73 \pm 2^\circ\text{F}$ [$23 \pm 1^\circ\text{C}$]. State in the test report any departure from this recommended condition.

8. Procedure

8.1 Place the specimen in the conditioning chamber and let it remain until equilibrium is obtained.

8.2 Place the specimen on a flat surface under the loading penetrator of the test machine. Force the penetrator into the specimen 0.25 ± 0.01 in. [6.5 ± 0.3 mm] below the original surface (**Note 1**) at a rate of 0.10 in./min [2.5 mm/min].

NOTE 1—The original surface is defined as the point where the

penetrator first contacts the specimen.

8.2.1 When possible, the penetrator shall bear between perforations or fissures when testing perforated or fissured material.

8.3 Record the load shown on the testing machine when the penetrator reaches the specified depression as the hardness of the specimen in newtons or pounds-force [newtons].

9. Report

9.1 The report shall include the following:

9.1.1 Identification of the test material,

9.1.2 Method of conditioning including time of conditioning, temperature, $^\circ\text{F}$ or $^\circ\text{C}$, and relative humidity, %,

9.1.3 Statement describing whether the finished or unfinished surface was tested and whether the face or the back of the specimen was tested,

9.1.4 Average thickness for the five specimens, in. or [mm],

9.1.5 Individual thicknesses for each of the five specimens, in. or [mm],

9.1.6 Average hardness for the five specimens, lbf or [N], and

9.1.7 Individual hardness for each of the five specimens, lbf or [N].

FRIABILITY

10. Significance and Use

10.1 The friability test measures the susceptibility of an acoustical product to edge and corner damage sustained during shipping, handling, and installing. Products that are friable and soft will erode considerably when subjected to rough treatment.

11. Apparatus

11.1 *Balance*, accurate to within 0.5 % of the weight of the smallest specimen tested.

11.2 *Testing Container*, consisting of an oak box with inside dimensions of $7\frac{3}{4}$ in. [200 mm] square by $7\frac{1}{2}$ in. [190 mm] deep and fitted with a cover on one end for inserting and removing the specimens. The box shall be mounted so that it can be rotated at 60 ± 2 r/min on a horizontal axis that is perpendicular to its square dimension.

11.3 *Red or White Oak Cubes*, 24, $\frac{3}{4} \pm \frac{1}{32}$ in. [19 ± 1 mm] on an edge, having a specific gravity of 0.65 ± 0.02 .

11.3.1 Number each group of wood cubes 1 to 24. At the end of every 600-revolution test period, remove one “used” cube (follow the number sequence and remove and discard the oldest cube) and replace with a corresponding numbered “new” cube. In this manner, cube wear is eliminated as an uncontrolled variable in the test method. When the corners of the wood cubes have been worn so that the radius of curvature is greater than $\frac{1}{16}$ in. [1.5 mm] or the cubes have become altered so as not to be comparable with new cubes, they shall be discarded and new ones used. A conventional machinist’s radius gage shall be used for checking the cube edge wear.

11.4 *Timer*, consisting of a watch or clock capable of measuring intervals of 10 min within ± 5.0 s.

12. Test Specimens

12.1 Cut twelve 1 by 1 in. [25 by 25 mm] square specimens from a single tile or panel. The specimen thickness is equal to the tile or panel thickness.

12.2 If the friability of original edges is of importance, separate tests shall be run on 1 by 1 in. [25 by 25 mm] specimens having one or two original edges.

13. Conditioning

13.1 Maintain standard conditions as described in 7.1 during preparation and testing of specimens.

14. Procedure

14.1 Weigh the twelve specimens and record the combined weight to the nearest 0.1 g.

14.2 Place the 12 specimens and the 24 oak cubes in the testing container. Close the top of the testing container and rotate the container about its axis at a speed of 60 rpm for two 10 min periods. At the end of each 10 min period, remove the specimens from the box and determine the percentage of mass loss, due to pulverization and breakage. In the case of badly abraded specimens, remove up to twelve of the largest pieces remaining and weigh these for the determination. In rare cases, no pieces may remain from an individual specimen. In this case, the weight loss shall be reported as 100 %.

15. Calculation

15.1 Calculate the percent mass loss for the 10 min and 20 min periods to two significant figures using Eq 1

$$\text{mass loss, \%} = [(M_1 - M_2)/M_1] \cdot 100 \quad (1)$$

M_1 = original mass, g, and

M_2 = mass after 10 min period and mass after 20 min period.

16. Report

16.1 The report shall include the following:

16.1.1 Identification of the test material,

16.1.2 Method of conditioning including time of conditioning, temperature, °F or [°C], and relative humidity, %, and

16.1.3 Percentage mass loss for the 10 and 20 min periods.

SAG

17. Significance and Use

17.1 This test method is for the purpose of determining the sag properties of ceiling tile or panels under various conditions of humidity exposure. Tiles or panels of various sizes can be tested by using appropriately sized supporting frames.

17.2 The test method will provide both the initial reading in reference to the plane of the edge support system and the total humidity-induced sag.

17.3 This test method is not designed to establish the expected performance of the ceiling panels under field condi-

tions of use, but only the sag properties for the specific temperature, humidity, exposure time, and mounting conditions used in the test.

18. Apparatus

18.1 *Controlled-Atmosphere Chamber (Environmental Chamber)*, capable of operating at a dry-bulb temperature of 73 to 90 $\pm 3^\circ\text{F}$ [23.0 to 32.0 $\pm 1.5^\circ\text{C}$], and relative humidities of 50, 60, 70, 80, or 90 ± 2 %. The chamber shall be equipped with suitable recording equipment to record wet- and dry-bulb temperatures (or dry bulb and relative humidity). This equipment shall be checked periodically and calibrated with a psychrometer that shall also be used to establish the test conditions.

18.2 *Sample Test Frames and Racks*, fabricated from non-ferrous metal, such as aluminum, and of suitable linear dimensions as shown in Fig. 1. Frames shall be constructed of $\frac{1}{4}$ by $1\frac{1}{2}$ in. [6 by 38 mm] angle with miter-cut corners. Inside surfaces of corners shall be welded and ground smooth. Frames shall be fabricated so they are level and square. Overall inside dimensions of the frames shall be such that the panels do not touch the vertical edges of the frame if they expand under prolonged exposure to conditions of high humidity.

18.2.1 Racks shall be constructed of a convenient design to hold one or more test frames in a horizontal plane; however, a sufficient distance shall be maintained between frames to permit adequate circulation of the test atmosphere and permit test measurements without moving panels.

18.3 *Zero-Plane Plate*—In the event that measurements are made using the zero-plane plate, means of zeroing the dial indicator (see 18.3.1), a zero-plane plate fabricated of $\frac{1}{4}$ in. [6 mm] thick by 3 in. [80 mm] wide steel or aluminum stock, shall be provided. The length of the plate shall be $\frac{1}{4}$ in. [6 mm] less than the inside width of the test frame.

18.3.1 In the case of panels with a width of 24 in. [610 mm] or less, an alternative means of zeroing the sag bar dial indicator shall be used. This consists of placing a zero-plane plate in the test specimen frame parallel with the shortest member of the frame, and centered in the longest member of the frame. The sag bar is then placed beneath the frame and the dial gage is adjusted to read zero at the plane of the specimen surface.

18.4 *Sag Bar*, equipped with a dial or digital gage indicator having a minimum movement of 1 in. [25 mm] calibrated in increments of 0.001 in. [0.025 mm] or less. The indicator shall be equipped with a 0.50 in. [13 mm] diameter pressure foot. The bar shall be equipped with individually adjustable feet having $\frac{3}{4}$ in. [20 mm] diameter bearing surfaces. The distance between centers of the bearing surfaces shall be equal to the nominal width of the test panel or tile. Fig. 2 shows a suitable sag bar design including spacing between bearing surfaces.

19. Test Specimens

19.1 Test specimens shall be full-size tile or panels as shipped for installation in the field.

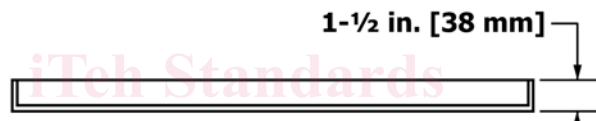
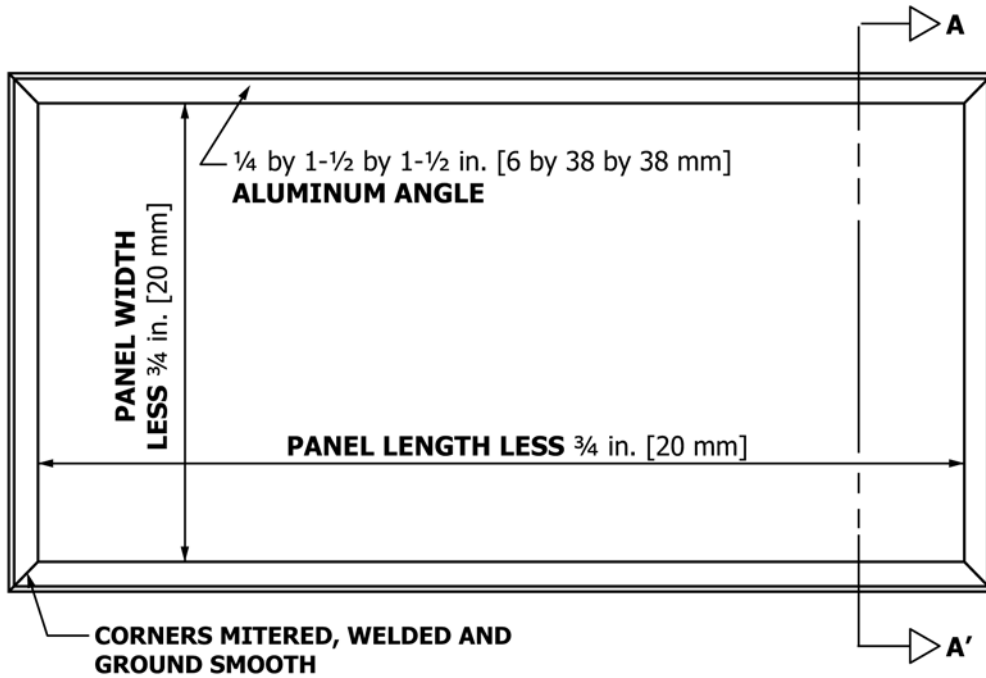

SECTION A-A'
 FIG. 1 Sag Test Frame

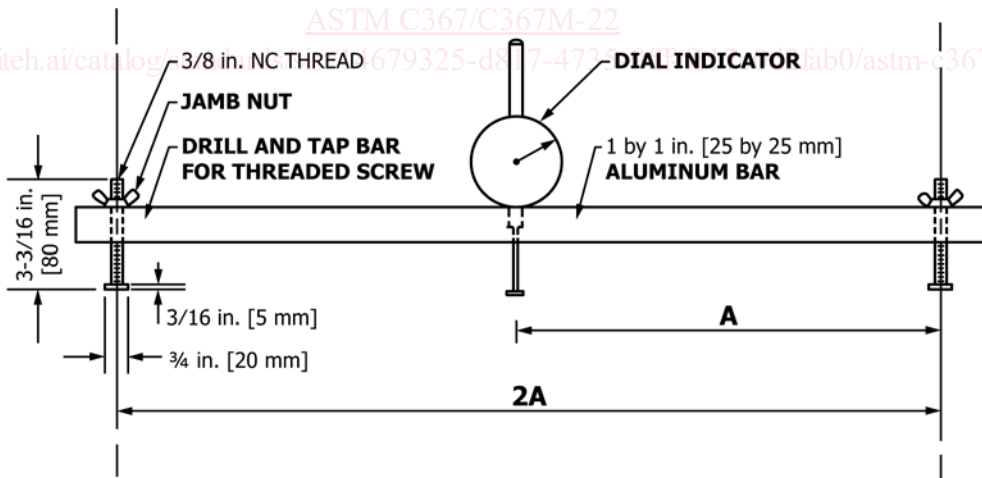

Panel Minimum Linear Dimension, in. [mm]	Dimension A, in. [mm]
12 [305]	6 [150]
24 [610]	12 [305]
48 [1220]	24 [610]
60 [1525]	30 [760]

FIG. 2 Sag Bar