



Designation: D1743 – 22

# Standard Test Method for Determining Corrosion Preventive Properties of Lubricating Greases<sup>1</sup>

This standard is issued under the fixed designation D1743; the number immediately following the designation indicates the year of original adoption or, in the case of revision, the year of last revision. A number in parentheses indicates the year of last reapproval. A superscript epsilon ( $\epsilon$ ) indicates an editorial change since the last revision or reapproval.

*This standard has been approved for use by agencies of the U.S. Department of Defense.*

## 1. Scope\*

1.1 This test method covers the determination of the corrosion preventive properties of greases using grease-lubricated tapered roller bearings stored under wet conditions. This test method is based on CRC Technique L 41<sup>2</sup> that shows correlations between laboratory results and service for grease lubricated aircraft wheel bearings.

1.2 *Apparatus Dimensions*—The values stated in SI units are to be regarded as standard. The values given in parentheses are for information only.

1.3 *All Other Values*—The values stated in SI units are to be regarded as standard. No other units of measurement are included in this standard.

1.4 *This standard does not purport to address all of the safety concerns, if any, associated with its use. It is the responsibility of the user of this standard to establish appropriate safety, health, and environmental practices and determine the applicability of regulatory limitations prior to use.*

1.5 *This international standard was developed in accordance with internationally recognized principles on standardization established in the Decision on Principles for the Development of International Standards, Guides and Recommendations issued by the World Trade Organization Technical Barriers to Trade (TBT) Committee.*

## 2. Referenced Documents

2.1 *ASTM Standards:*<sup>3</sup>

D1193 Specification for Reagent Water

<sup>1</sup> This test method is under the jurisdiction of ASTM Committee D02 on Petroleum Products, Liquid Fuels, and Lubricants and is the direct responsibility of Subcommittee D02.G0.06 on Functional Tests - Contamination.

Current edition approved May 1, 2022. Published May 2022. Originally approved in 1960. Last previous edition approved in 2021 as D1743 – 21. DOI: 10.1520/D1743-22.

<sup>2</sup> “Research Technique for Determining Rust-Preventive Properties of Lubricating Greases in the Presence of Free Water,” L-41-957, undated, Coordinating Research Council, Inc., 219 Perimeter Center Parkway, Atlanta, GA 30346.

<sup>3</sup> For referenced ASTM standards, visit the ASTM website, [www.astm.org](http://www.astm.org), or contact ASTM Customer Service at [service@astm.org](mailto:service@astm.org). For *Annual Book of ASTM Standards* volume information, refer to the standard’s Document Summary page on the ASTM website.

D5969 Test Method for Corrosion-Preventive Properties of Lubricating Greases in Presence of Dilute Synthetic Sea Water Environments

## 3. Terminology

3.1 *Definitions of Terms Specific to This Standard:*

3.1.1 *corrosion, n*—the chemical or electrochemical reaction between a material, usually a metal, and its environment that produces a deterioration of the material and its properties.

3.1.1.1 *Discussion*—In this test method, corrosion is manifested by red rust or black stains on the bearing race. Stains, through which the underlying metal surface is still visible, are not considered corrosion in Test Method D1743 and shall be ignored.

## 4. Summary of Test Method

4.1 New, cleaned, and lubricated bearings are run under a light thrust load for  $60\text{ s} \pm 3\text{ s}$  to distribute the lubricant in a pattern that might be found in service. The bearings are exposed to water, then stored for  $48\text{ h} \pm 0.5\text{ h}$  at  $52\text{ }^\circ\text{C} \pm 1\text{ }^\circ\text{C}$  ( $125\text{ }^\circ\text{F} \pm 2\text{ }^\circ\text{F}$ ) and 100 % relative humidity. After cleaning, the bearing cups are examined for evidence of corrosion.

## 5. Significance and Use

5.1 This test method differentiates the relative corrosion-preventive capabilities of lubricating greases under the conditions of the test.

## 6. Apparatus

6.1 *Bearings*—Timken bearing cone and roller assembly LM11949, and cup LM11910.<sup>4,5</sup>

6.2 *Motor*, 1750 r/min  $\pm$  50 r/min speed,  $\frac{1}{15}$  hp (min).

6.3 *Bearing Holder*, consists of a  $1\text{ kg} \pm 0.010\text{ kg}$  weight, upper and lower plastic collars for the bearing cone (Parts A and B), a metal screw, and a plastic collar for the cup (Part C). (See Fig. 1.)

<sup>4</sup> The sole source of supply of the apparatus known to the committee at this time is The Timken Co., Canton, OH 44706.

<sup>5</sup> If you are aware of alternative suppliers, please provide this information to ASTM International Headquarters. Your comments will receive careful consideration at a meeting of the responsible technical committee,<sup>1</sup> which you may attend.

\*A Summary of Changes section appears at the end of this standard

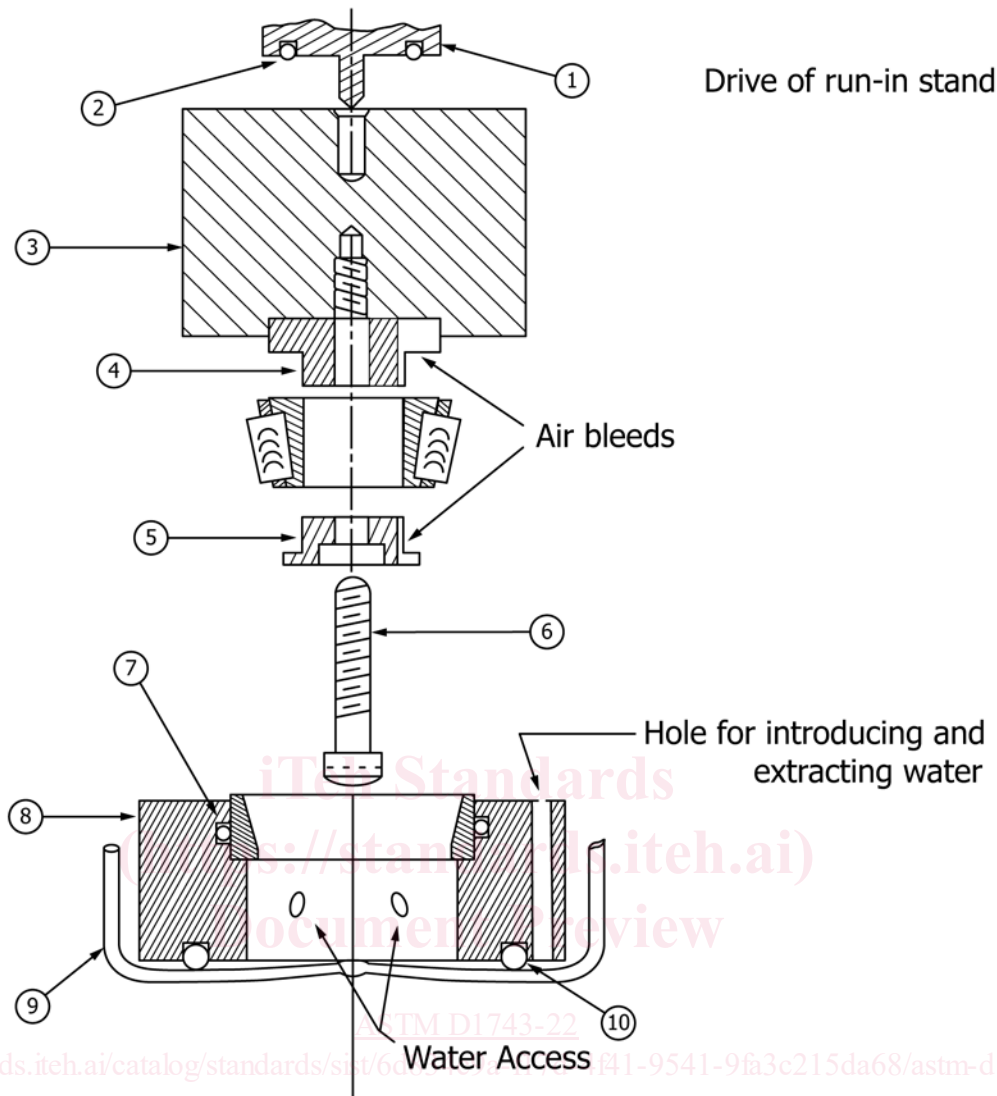

KEY	DESCRIPTION	QUANTITY
1	PISTON	1
2	O RING	1
3	WEIGHT	1
4	UPPER FLANGE	1
5	LOWER FLANGE	1
6	1/4 - 20 x 1-1/4 FILLISTER HD. MACH. SCREW S.S.	1
7	O RING	1
8	BEARING HOLDER	1
9	PLASTIC JAR	1
10	O RING	1

FIG. 1 Bearing Holder Assembly

6.4 *Plastic Test Jar*, as shown in Fig. 2.

6.5 *Run-in Stand*, as shown in Fig. 3.

6.6 *Spindle/Thrust Loading Device*, as shown in Fig. 4. (See Table 1 for metric equivalents.)

6.7 *Mechanical Grease Packer*, as shown in Fig. 5 and Fig. 6.

6.8 *Pliers*,<sup>5,6</sup> as shown in Fig. 7.

6.9 *Syringe*, of at least 100 mL volume and with a needle of at least 16 gauge and a minimum length of 100 mm (4 in.).

6.10 *Timer*, capable of measuring a 60 s ± 3 s interval.

6.11 *Oven*—A laboratory oven, essentially free of vibration, capable of maintaining 52 °C ± 1 °C.

## 7. Reagents

7.1 *Purity of Reagents*—Reagent grade chemicals shall be used in all tests. Unless otherwise indicated, it is intended that all reagents shall conform to the specifications of the Committee on Analytical Reagents of the American Chemical Society, where such specifications are available.<sup>7</sup> Other grades may be used, provided it is first ascertained that the reagent is of

<sup>6</sup> The sole source of supply of the Waldes Truarc Plier No. 4 modified as in Fig. 7 known to the committee at this time is TRUARC Company LLC, 70 East Willow Street, Millburn, NJ 07041.

<sup>7</sup> ACS Reagent Chemicals, Specifications and Procedures for Reagents and Standard-Grade Reference Materials, American Chemical Society, Washington, DC. For suggestions on the testing of reagents not listed by the American Chemical Society, see *Analar Standards for Laboratory Chemicals*, BDH Ltd., Poole, Dorset, U.K., and the *United States Pharmacopeia and National Formulary*, U.S. Pharmacopeial Convention, Inc. (USPC), Rockville, MD.

sufficiently high purity to permit its use without lessening the accuracy of the determination.

7.2 *Purity of Water*—Unless otherwise indicated, references to water shall be understood to mean freshly boiled double distilled water, or water conforming to Specification D1193, Type II.

7.3 *Isopropyl Alcohol*. **Warning**—Flammable.

7.4 *Solvent Rinse Solution* of the following composition by volume:

7.4.1 *Isopropyl Alcohol*, 90 %.

7.4.2 *Distilled Water*, 9 %.

7.4.3 *Ammonium Hydroxide*, 1 %. **Warning**—Poison. Causes burns. Vapor extremely irritating. Can be fatal if swallowed. Harmful if inhaled.

7.5 *Mineral Spirits*, reagent grade, minimum purity. (**Warning**—Combustible. Vapor harmful.)

## 8. Standardization of Thrust Loading Device

8.1 Pack a bearing, install it into the holder and place the assembly into a plastic jar as described in 10.1 through 10.4. Place the jar onto the base of the motor drive spindle and center it under the indexing pin of the drive. Lower the drive until the O ring just contacts the 1 kg weight. Run the bottom nut of the depth gage (see Fig. 3) down to the stop. Place a 3 mm spacer on top of this nut. Bring the top nut down to the spacer. While holding the top nut in position, remove the spacer and run the bottom nut up and tighten it against the top nut. Alternative thrust loading device manufacturers may have different instructions for setting the 3 mm compression depth, in this case the manufacturer's instructions should be followed. When the O ring is compressed against the 1 kg weight until the adjustment nut hits the stop, there will be a 29 N load added, giving a total load of 39 N on the bearing. (The loads described are provided by the forces of the spring in the thrust loading spindle and sum of the 1 kg weight and spring, respectively. These loads are approximate. The 1 kg weights should be within 0.010 kg of their stated values. The thrust loading spindle should be calibrated by some suitable method when it is first put into service, recalibrated periodically, and replaced if its spring does not provide sufficient force to spin the test bearings without slippage during the 60 s run to distribute the grease.) Examine the O ring periodically and replace it if it shows any cracks or other signs of deterioration.

8.2 The thrust loading device should be standardized before use, once per day if used daily, and again if there is reason to believe that the standardization has changed. The thrust loading device may be standardized using one of the greases to be tested.

## 9. Preparation of Bearings

9.1 Examine the test bearings carefully and select only bearings that have outer races (cups) and rollers entirely free of corrosion. During the bearing preparation handle the bearings with tongs or rubber or plastic gloves. Do not touch bearings with the fingers at any time.

9.2 Wash the selected bearing thoroughly in hot (52 °C to 66 °C) mineral spirits, reagent grade (**Warning**—Combustible.

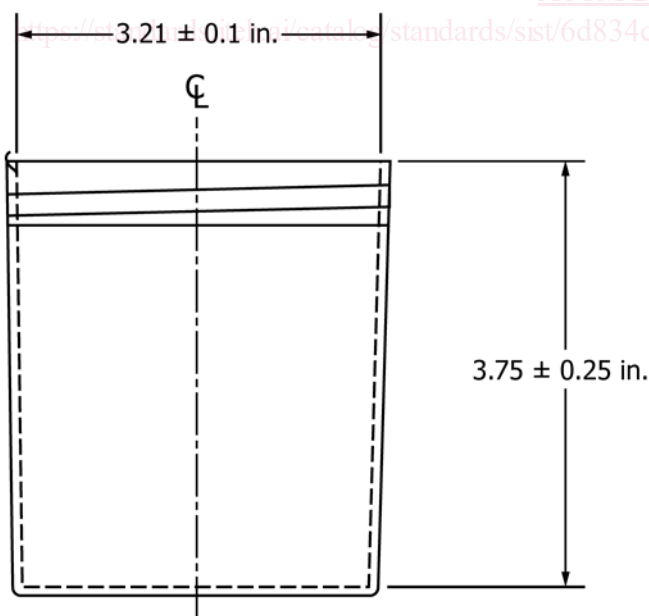

Test Jar Specifications  
 Inner Diameter Range: 3.11 in. – 3.31 in. (79 mm – 84 mm)  
 Inner Height Range: 3.5 in. – 4.0 in. (89 mm – 102 mm)

FIG. 2 Plastic Test Jar

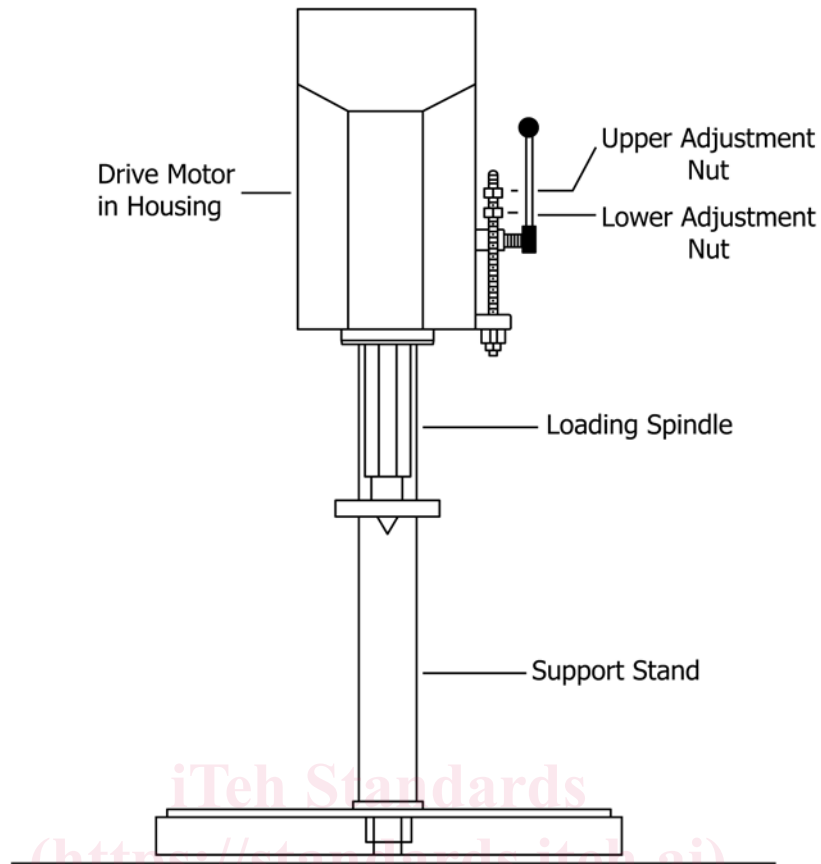

FIG. 3 Run-in Stand Drawing

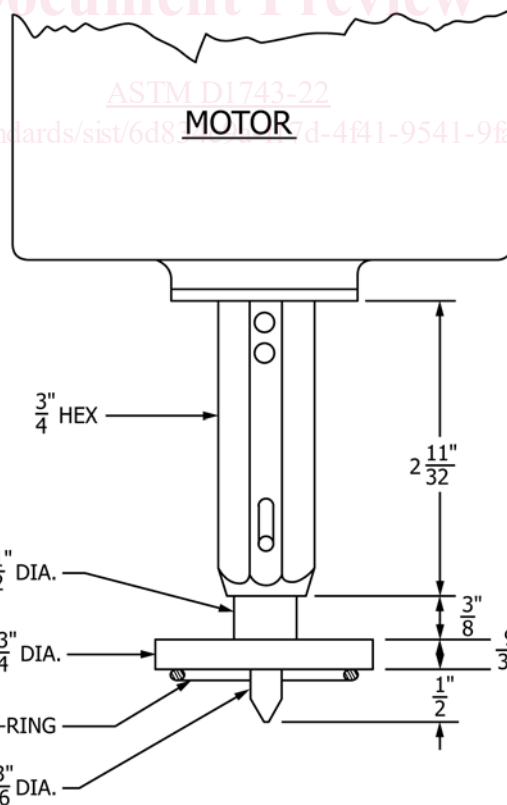

FIG. 4 Spindle/Thrust Loading Device

**TABLE 1 Metric Equivalents for Figs. 3 and 4**

Inches	Millimetres
1/32	0.79
1/8	3.18
5/32	3.97
3/16	4.76
5/32	7.14
5/16	7.94
3/8	9.53
7/16	11.11
1/2	12.70
19/32	15.08
21/32	16.67
3/4	19.05
1	25.40
1 1/8	28.58
1 3/16	31.26
1 1/4	31.75
1 11/32	34.13
1.495	37.97
1.500	38.10
1 9/16	39.69
1 1/4	44.45
1.785	45.34
1 5/16	49.21
1.946	49.43
2 7/32	56.36
2 1/4	57.15
2 11/32	59.53
3	76.20

Vapor harmful.) to remove the rust preventive. Wipe the bearing cone and cup with tissue moistened in hot solvent to remove any remaining residue. Rinse the bearing a second time in fresh, hot mineral spirits, reagent grade.

NOTE 1—The washing temperatures specified are considerably above the flash point of the mineral spirits, reagent grade. Accordingly, the washing operation should be carried out in a well-ventilated hood where no flames or other ignition sources are present.

9.3 Transfer the bearing from the mineral spirits, reagent grade to the solvent rinse solution (**Warning—Poison. Causes burns. Vapor extremely irritating. Can be fatal if swallowed. Harmful if inhaled.**) to remove the mineral spirits, reagent grade and any fingerprints that are present. Then rinse the bearing and slowly rotate in fresh hot ( $66\text{ }^{\circ}\text{C} \pm 5\text{ }^{\circ}\text{C}$ ) solvent rinse solution.

NOTE 2—Use fresh rinse solution to avoid the selective evaporation of the components at the rinse temperature.

9.4 Remove the bearing from the solvent rinse solution and place on filter paper to drain. After draining, dry the bearing in an oven at  $70\text{ }^{\circ}\text{C} \pm 5\text{ }^{\circ}\text{C}$  for 15 min to 30 min.

9.5 Permit the bearing to cool to room temperature and reexamine surfaces to assure that corrosion-free and free-turning specimens have been selected. (Care should be taken not to spin the bearings after cleaning and drying.)

9.6 Wash and dry the bearing packer using the same technique as for the preparation of the bearings.

## 10. Procedure

10.1 With the reservoir of grease packer resting on a clean bench top, and while wearing gloves, place bearing cup with small diameter face down into the recess of the packer. Place the bearing cone over the cup, and while holding the bearing

assembly against the packer, lift and invert the whole unit and return it to the bench.

10.2 Fill the reservoir with the grease sample, and use the plunger to force grease through the bearing. Carefully remove the plunger from the reservoir to avoid sucking air into the bearing, and slide the packer unit over the edge of the bench. While holding the bearing assembly in the packer, invert the unit to its original position on the bench.

10.3 Using a small square-ended spatula, remove excess grease from the bearing bore and the annulus between the grease packer and outer perimeter of the bearing cup. The bearing is removed from the packer by either use of the pliers or by placing gloved index finger in the bore and lifting out. While holding the bearing, use the spatula to remove excess grease above the cage on both sides of the bearing. This procedure is done to ensure that approximately the same volume of grease is used each time.

10.4 Using Fig. 1 as a guide, hold the packed bearing between gloved fingers with large inside diameter of cup downward and insert the small diameter plastic flange on top of the bore, and the larger flange into the bottom of the bore. Slide the bearing assembly onto the 1 kg weight so that the large diameter flange fits into the recess on the top of the weight. Insert the bolt through the assembly and screw the bolt tightly into the weight. Lower the plastic bearing holder (Part 8) over the bearing (the large **O** ring faces upward). Press down the holder so that the bearing fits squarely into the holder.

NOTE 3—If bearing holders and plastic test jars are used interchangeably for Test Method D5969 and D1743, thoroughly clean the test apparatus to prevent contamination affecting the test results.

10.5 Invert a plastic jar over the bearing assembly. Slide the two components over the edge of the bench, and with fingers pressing the weight against the inner bottom of the jar, invert the entire assembly.

10.6 Place the jar onto the base of the motor driven spindle and center under the indexing pin of the drive. Start the motor and bring the drive into the center of the 1 kg weight and load until the nut hits the depth stop. Run for 60 s, raise the drive, and allow the bearing to coast to a stop. Extreme care should be taken not to break the contact between the races and rollers at this point and in the following steps.

10.6.1 At no time during or after the 60 s run shall the grease be redistributed or forced back into the bearing.

10.7 Freshly boil the distilled water for  $10\text{ min} \pm 5\text{ min}$  to remove carbon dioxide and cool to  $25\text{ }^{\circ}\text{C} \pm 5\text{ }^{\circ}\text{C}$ .

10.8 Fill a clean syringe with  $100\text{ mL} \pm 5\text{ mL}$  of distilled water from 10.7. With the run-in bearing in the jar, simultaneously start a timer and begin adding the water into the hole provided for this purpose in the bearing holder. Add the 100 mL of water within  $20\text{ s} \pm 3\text{ s}$ . When the timer shows  $50\text{ s} \pm 3\text{ s}$  start withdrawing the water. When the timer shows  $60\text{ s} \pm 3\text{ s}$ , complete the withdrawal of  $70\text{ mL} \pm 5\text{ mL}$  of water. Leave the remaining  $30\text{ mL} \pm 5\text{ mL}$  of water in the jar. Make sure that water does not touch the bearing after  $70\text{ mL} \pm 5\text{ mL}$  is withdrawn. It may be difficult to withdraw  $70\text{ mL} \pm 5\text{ mL}$  water in 10 s using a 16 gauge needle. A larger needle may be required.

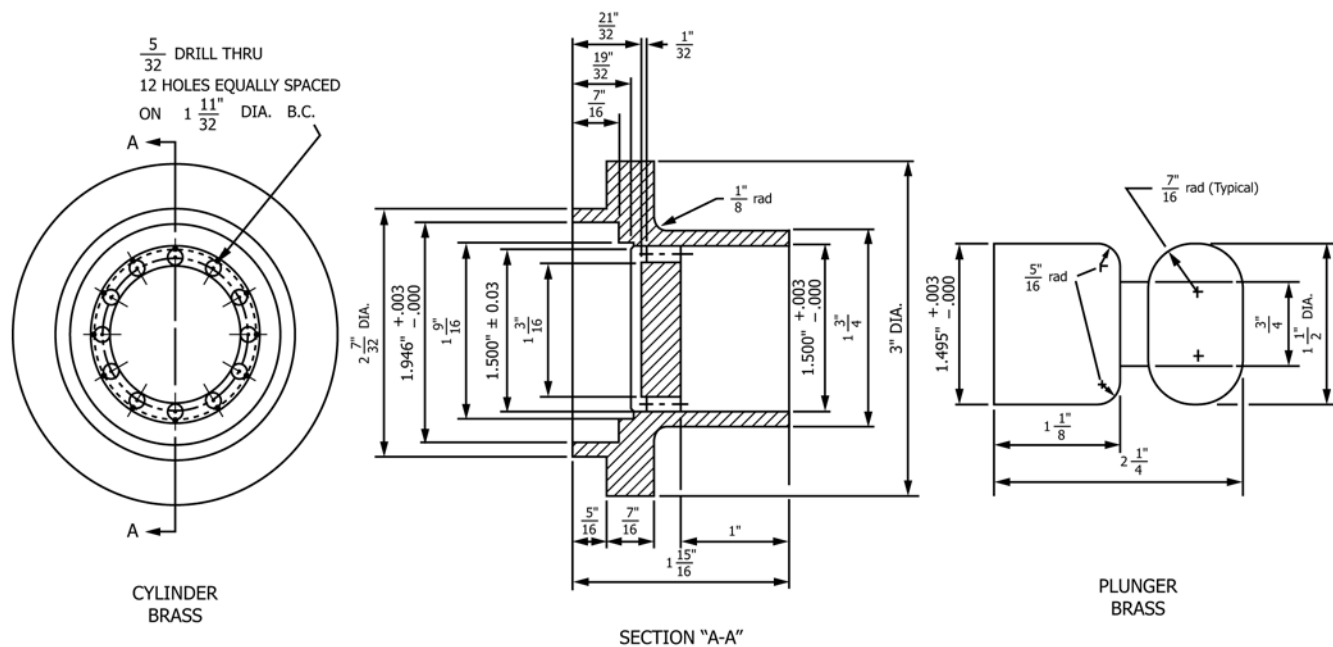

NOTE 1—Tolerances are 0.003 in. unless specified otherwise.

FIG. 5 Bearing Packer Brass

10.9 Screw the cap on the jar and transfer to a dark oven essentially free from vibration for 48 h at  $52 \text{ }^\circ\text{C} \pm 1 \text{ }^\circ\text{C}$ .

10.10 Prepare three bearings with each grease to be tested. Each group of three bearings is one test.

### 11. Rating Procedure

11.1 Remove the bearing from the test jar and place the bearing cup in a 50 + 50 mixture by volume of isopropyl alcohol (**Warning**—Flammable) and mineral spirits, reagent grade (**Warning**—Combustible. Vapor harmful). The solvent mixture can be heated to facilitate the removal of the grease. Agitate vigorously to remove the grease. Repeat the rinsing using fresh solvent mixture or gently wipe the bearing with a clean cloth or tissue to ensure that traces of grease are removed.

11.2 Transfer the bearing cup from the solvent and allow to dry on clean filter paper.

11.3 Examine the cup raceway for evidence of corrosion without the use of magnification (Section 5). Use only a pass or fail rating. Criteria for failure shall be the presence of any corrosion spot 1.0 mm or larger in the longest dimension. Ignore the number of spots.

11.3.1 Spots that are easily removed by rubbing lightly with soft tissue (alone or wetted with any solvent nonreactive to rust or steel at room temperature) shall not be considered as corrosion in the rating.

### 12. Report

12.1 The reported result shall be the pass or fail rating as determined by at least two of the three bearings.

### 13. Precision and Bias

13.1 Due to the nature of the results, the precision of this test method was not obtained in accordance with RR:D02-1007, "Manual on Determining Precision Data for ASTM Methods on Petroleum Products and Lubricants."

13.2 *Precision*—The precision of this test method as determined by statistical examination of interlaboratory results is as follows:

13.2.1 *Repeatability* may be judged by the fact that 94 % of duplicate results obtained by nine laboratories with six samples were in agreement.

13.2.2 *Reproducibility* may be judged by the fact that nine laboratories matched consensus 96 % of the time with six samples showing good or poor protection against corrosion.

13.3 *Bias*—No statement is made about the bias of this test method since the result merely states whether there is conformance to the criteria for success specified in the procedure.

### 14. Keywords

14.1 bearing; corrosion; lubricating grease; rust

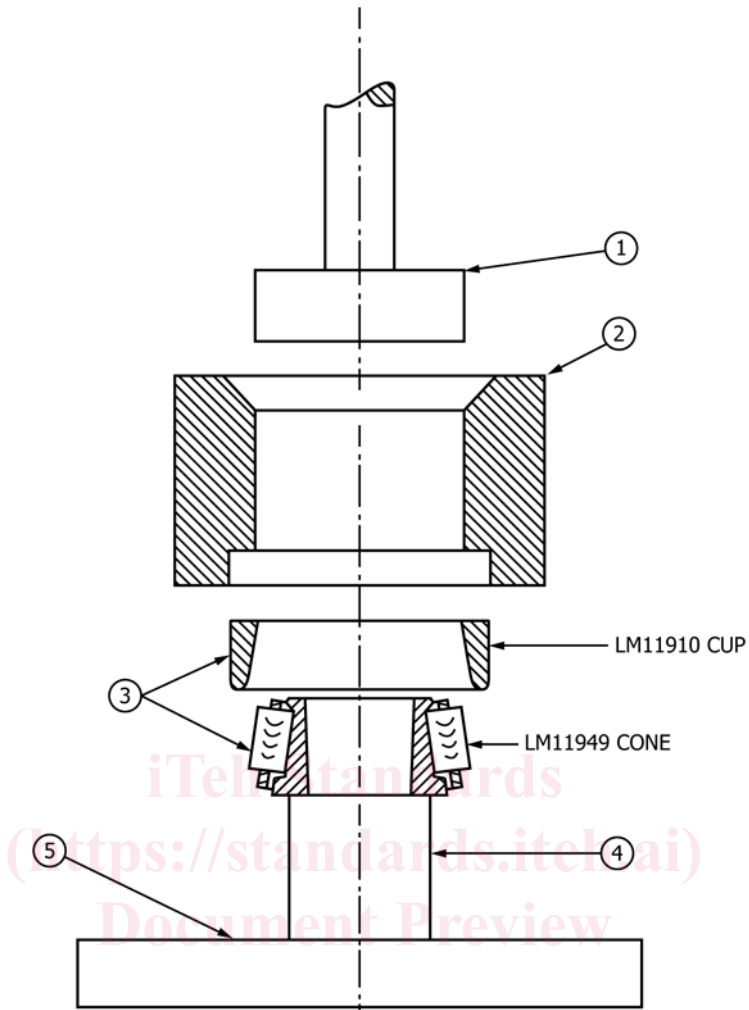

<https://standards.iteh.ai/catalog/standards/sist/6d834c7a-f17d-4f41-9541-9fa3c215da68/astm-d1743-22>

KEY	DESCRIPTION	QUANTITY
1	GREASE PACK PLUNGER	1
2	CYLINDER	1
3	LM11900 BEARING ASSEMBLY	1
4	STUD	1
5	BASE	1

FIG. 6 Bearing Packer—Alternative