

INTERNATIONAL
STANDARD

IEC
60297-3-103

First edition
2004-08

**Mechanical structures for electronic equipment –
Dimensions of mechanical structures
of the 482,6 mm (19 in) series –**

Part 3-103:

Keying and alignment pin
(standards.iteh.ai)

[IEC 60297-3-103:2004](https://standards.iteh.ai/catalog/standards/sist/ff937fc5-6d70-4d3e-a95e-fdd786a9cd29/iec-60297-3-103-2004)

<https://standards.iteh.ai/catalog/standards/sist/ff937fc5-6d70-4d3e-a95e-fdd786a9cd29/iec-60297-3-103-2004>



Reference number
IEC 60297-3-103:2004(E)

Publication numbering

As from 1 January 1997 all IEC publications are issued with a designation in the 60000 series. For example, IEC 34-1 is now referred to as IEC 60034-1.

Consolidated editions

The IEC is now publishing consolidated versions of its publications. For example, edition numbers 1.0, 1.1 and 1.2 refer, respectively, to the base publication, the base publication incorporating amendment 1 and the base publication incorporating amendments 1 and 2.

Further information on IEC publications

The technical content of IEC publications is kept under constant review by the IEC, thus ensuring that the content reflects current technology. Information relating to this publication, including its validity, is available in the IEC Catalogue of publications (see below) in addition to new editions, amendments and corrigenda. Information on the subjects under consideration and work in progress undertaken by the technical committee which has prepared this publication, as well as the list of publications issued, is also available from the following:

- **IEC Web Site** (www.iec.ch)
- **Catalogue of IEC publications**
The on-line catalogue on the IEC web site (www.iec.ch/searchpub) enables you to search by a variety of criteria including text searches, technical committees and date of publication. On-line information is also available on recently issued publications, withdrawn and replaced publications, as well as corrigenda.
- **IEC Just Published** (standards.iteh.ai)
This summary of recently issued publications (www.iec.ch/online_news/justpub) is also available by email. Please contact the Customer Service Centre (see below) for further information.
<https://standards.iteh.ai/catalog/standards/sist/ff937fc5-6d70-4d3e-a95e-1dd78da9cd29/iec-60297-3-103-2004>
- **Customer Service Centre**
If you have any questions regarding this publication or need further assistance, please contact the Customer Service Centre:

Email: custserv@iec.ch
Tel: +41 22 919 02 11
Fax: +41 22 919 03 00

INTERNATIONAL STANDARD

IEC 60297-3-103

First edition
2004-08

Mechanical structures for electronic equipment – Dimensions of mechanical structures of the 482,6 mm (19 in) series –

Part 3-103:

Keying and alignment pin (standards.iteh.ai)

[IEC 60297-3-103:2004](#)

<https://standards.iteh.ai/catalog/standards/sist/ff937fc5-6d70-4d3e-a95e-fdd786a9cd29/iec-60297-3-103-2004>

© IEC 2004 — Copyright - all rights reserved

No part of this publication may be reproduced or utilized in any form or by any means, electronic or mechanical, including photocopying and microfilm, without permission in writing from the publisher.

International Electrotechnical Commission, 3, rue de Varembe, PO Box 131, CH-1211 Geneva 20, Switzerland
Telephone: +41 22 919 02 11 Telefax: +41 22 919 03 00 E-mail: inmail@iec.ch Web: www.iec.ch



Commission Electrotechnique Internationale
International Electrotechnical Commission
Международная Электротехническая Комиссия

PRICE CODE

P

For price, see current catalogue

CONTENTS

FOREWORD.....	3
INTRODUCTION.....	5
1 Scope and object.....	6
2 Normative references	6
3 Terms and definitions	6
4 Arrangement overview: Keying of plug-in units in a subrack.....	7
4.1 General	7
4.2 Subrack interface dimensions for keying	8
4.3 Plug-in unit keying interface dimensions.....	8
4.4 Key dimensions	9
4.5 Programming of keys	9
4.6 Keying chamber inspection dimensions	10
5 Arrangement overview: alignment and/or electrical contact of a plug-in unit to a subrack	11
5.1 General	11
5.2 Alignment and/or electrical contact receptacle in the subrack guide rail for printed board type plug-in units (width dimension $\geq 4 \times 5,08$ mm).....	12
5.3 Alignment and/or electrical contact interface inspection dimensions.....	13
6 Arrangement overview: Subrack guide rail and printed board, 2,54 mm offset of the printed board reference plane	14
6.1 General	14
6.2 Dimensions of the subrack guide rail with 2,54 mm offset of the printed board reference plane	15
6.3 Reference plane for printed boards with 2,54 mm offset position.....	15
7 Dimensions used in the figures	16
Figure 1 – Relationship between the new IEC 60297-3 series and the old IEC 60297 series	5
Figure 2 – Keying of a plug-in unit in a subrack	7
Figure 3 – Subrack interface dimensions for keying	8
Figure 4 – Plug-in unit keying interface dimensions	8
Figure 5 – Key dimensions	9
Figure 6 – Programming of keys.....	9
Figure 7 – Front and/or rear subrack and plug-in unit keying chamber inspection dimensions	10
Figure 8 – Alignment and/or electrical contact of a plug-in unit to a subrack	11
Figure 9 – Alignment and/or electrical contact receptacle position in the subrack	12
Figure 10 – Alignment and/or electrical contact interface inspection dimensions.....	13
Figure 11 – Subrack guide rail and printed board, 2,54 mm offset of the printed board reference plane	14
Figure 12 – Dimensions of the subrack guide rail with 2,54 mm offset of the printed board reference plane.....	15
Figure 13 – Reference plane for printed boards with 2,54 mm offset position.....	15

INTERNATIONAL ELECTROTECHNICAL COMMISSION

**MECHANICAL STRUCTURES FOR ELECTRONIC EQUIPMENT –
DIMENSIONS OF MECHANICAL STRUCTURES
OF THE 482,6 mm (19 in) SERIES –**

Part 3-103: Keying and alignment pin

FOREWORD

- 1) The International Electrotechnical Commission (IEC) is a worldwide organization for standardization comprising all national electrotechnical committees (IEC National Committees). The object of IEC is to promote international co-operation on all questions concerning standardization in the electrical and electronic fields. To this end and in addition to other activities, IEC publishes International Standards, Technical Specifications, Technical Reports, Publicly Available Specifications (PAS) and Guides (hereafter referred to as "IEC Publication(s)"). Their preparation is entrusted to technical committees; any IEC National Committee interested in the subject dealt with may participate in this preparatory work. International, governmental and non-governmental organizations liaising with the IEC also participate in this preparation. IEC collaborates closely with the International Organization for Standardization (ISO) in accordance with conditions determined by agreement between the two organizations.
- 2) The formal decisions or agreements of IEC on technical matters express, as nearly as possible, an international consensus of opinion on the relevant subjects since each technical committee has representation from all interested IEC National Committees.
- 3) IEC Publications have the form of recommendations for international use and are accepted by IEC National Committees in that sense. While all reasonable efforts are made to ensure that the technical content of IEC Publications is accurate, IEC cannot be held responsible for the way in which they are used or for any misinterpretation by any end user.
- 4) In order to promote international uniformity, IEC National Committees undertake to apply IEC Publications transparently to the maximum extent possible in their national and regional publications. Any divergence between any IEC Publication and the corresponding national or regional publication shall be clearly indicated in the latter.
- 5) IEC provides no marking procedure to indicate its approval and cannot be rendered responsible for any equipment declared to be in conformity with an IEC Publication.
- 6) All users should ensure that they have the latest edition of this publication.
- 7) No liability shall attach to IEC or its directors, employees, servants or agents including individual experts and members of its technical committees and IEC National Committees for any personal injury, property damage or other damage of any nature whatsoever, whether direct or indirect, or for costs (including legal fees) and expenses arising out of the publication, use of, or reliance upon, this IEC Publication or any other IEC Publications.
- 8) Attention is drawn to the Normative references cited in this publication. Use of the referenced publications is indispensable for the correct application of this publication.
- 9) Attention is drawn to the possibility that some of the elements of this IEC Publication may be the subject of patent rights. IEC shall not be held responsible for identifying any or all such patent rights.

International Standard IEC 60297-3-103 has been prepared by subcommittee 48D: Mechanical structures for electronic equipment, of IEC technical committee 48: Electro-mechanical components and mechanical structures for electronic equipment.

This standard cancels and replaces IEC 60297-5-104 and 60297-5-105.

The text of this standard is based on following documents:

FDIS	Report on voting
48D/301/FDIS	48D/308/RVD

Full information on the voting for the approval of this standard can be found in the report on voting indicated in the above table.

This publication has been drafted in accordance with the ISO/IEC Directives, Part 2.

The IEC 60297-3 series consists of the following parts, under the general title *Mechanical structures for electronic equipment – Dimensions of mechanical structures of the 482,6 mm (19 in) series*

Part 3-101: Subracks and associated plug-in units

Part 3-102: Injector/extractor handle

Part 3-103: Keying and alignment pin

The committee has decided that the contents of this publication will remain unchanged until the maintenance result date indicated on the IEC web site under "<http://webstore.iec.ch>" in the data related to the specific publication. At this date, the publication will be

- reconfirmed;
- withdrawn;
- replaced by a revised edition, or
- amended.

A bilingual edition of this standard may be issued at a later date.

iTeh STANDARD PREVIEW (standards.iteh.ai)

[IEC 60297-3-103:2004](https://standards.iteh.ai/catalog/standards/sist/ff937fc5-6d70-4d3e-a95e-fdd786a9cd29/iec-60297-3-103-2004)

<https://standards.iteh.ai/catalog/standards/sist/ff937fc5-6d70-4d3e-a95e-fdd786a9cd29/iec-60297-3-103-2004>

INTRODUCTION

The “Dimensions of mechanical structures of the 482,6 mm (19 in) standards are defined in IEC 60297. To the original IEC 60297-3:1988 publication was added Amendment 1:1995. The additional requirements were published in IEC 60297-4:1995 with Amendment 1:1999.

The extended requirements were published in the IEC 60297-5-1XX series (2001). Responding to market requirements and for more clarity it became necessary to merge and technically enhance these standard “parts” into 3 “new” standards for subracks and associated plug-in units. This “merged” standard series now defined as IEC 60297-3-101, IEC 60297-3-102 and IEC 60297-3-103 explains its relationship to the previous “fragmented” IEC 60297-X standards, see Figure 1.

The nomenclature of these new standards has been revised. The relationship to IEC 60297-1 (Part 1: Panels and Racks) has been maintained. The relationship to IEC 60297-2 (Part 2: Cabinets and pitches of rack structures) has been maintained. The relationship to IEC 61587-1 (Part 1: Climatic, mechanical tests and safety aspects for cabinets, racks, subracks and chassis) and IEC TS 61587-3 (Part 3: Electromagnetic shielding performance tests for cabinets, racks and subracks) has been added.

IEC 60297-3-103 defines only the interface dimensions for an alignment pin and a keying device which are additional to those defined in IEC 60297-3-101.

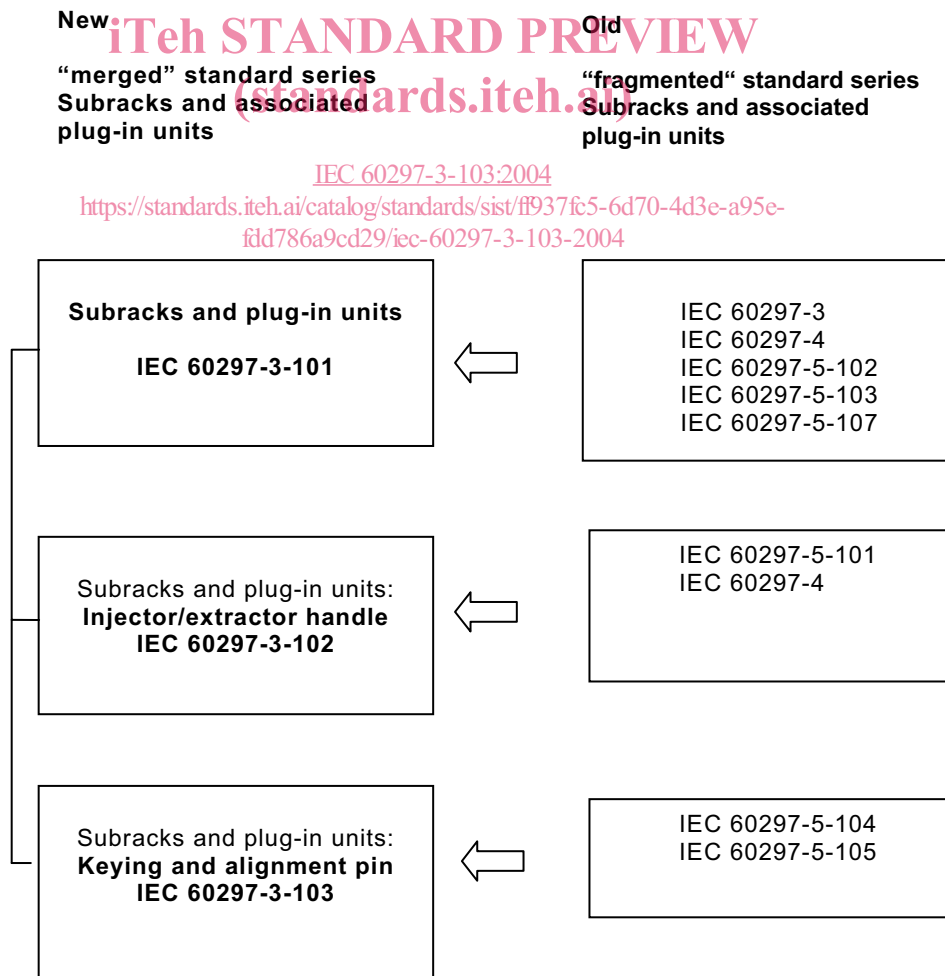

IEC 1089/04

Figure 1 – Relationship between the new IEC 60297-3 series and the old IEC 60297 series

MECHANICAL STRUCTURES FOR ELECTRONIC EQUIPMENT – DIMENSIONS OF MECHANICAL STRUCTURES OF THE 482,6 mm (19 in) SERIES –

Part 3-103: Keying and alignment pin

1 Scope and object

This part of IEC 60297 covers only the additional interface dimensions for an alignment pin and a keying device used with subracks and plug-in units according to IEC 60297-3-101. This standard may also be used in conjunction with IEC 60297-3-102.

2 Normative references

The following referenced documents are indispensable for the application of this document. For dated references, only the edition cited applies. For undated references, the latest edition of the referenced document (including any amendments) applies.

IEC 60297-3-101, *Dimensions of mechanical structures of the 482,6 mm (19 in) series – Part 3-101: Subracks and associated plug-in units*

IEC 60297-3-102, *Dimensions of mechanical structures of the 482,6 mm (19 in) series – Part 3-102: Injector/extractor handle*

[IEC 60297-3-103:2004](#)

IEC 60917-1:1998, *Modular order for the development of mechanical structures for electronic equipment practices*

3 Terms and definitions

For the purposes of this part of IEC 60297, the terms and definitions given in IEC 60917-1 apply.

4 Arrangement overview: Keying of plug-in units in a subrack

4.1 General

This method of keying will prevent misarrangement of board type plug-in units into subracks.

The keys shall be snap-in mounted for the purpose of change and/or retrofit in accordance to the application order.

The keying feature needs the special retainer on the plug-in unit as well as on the subrack guiderail, as shown by Figures 2 to 7.

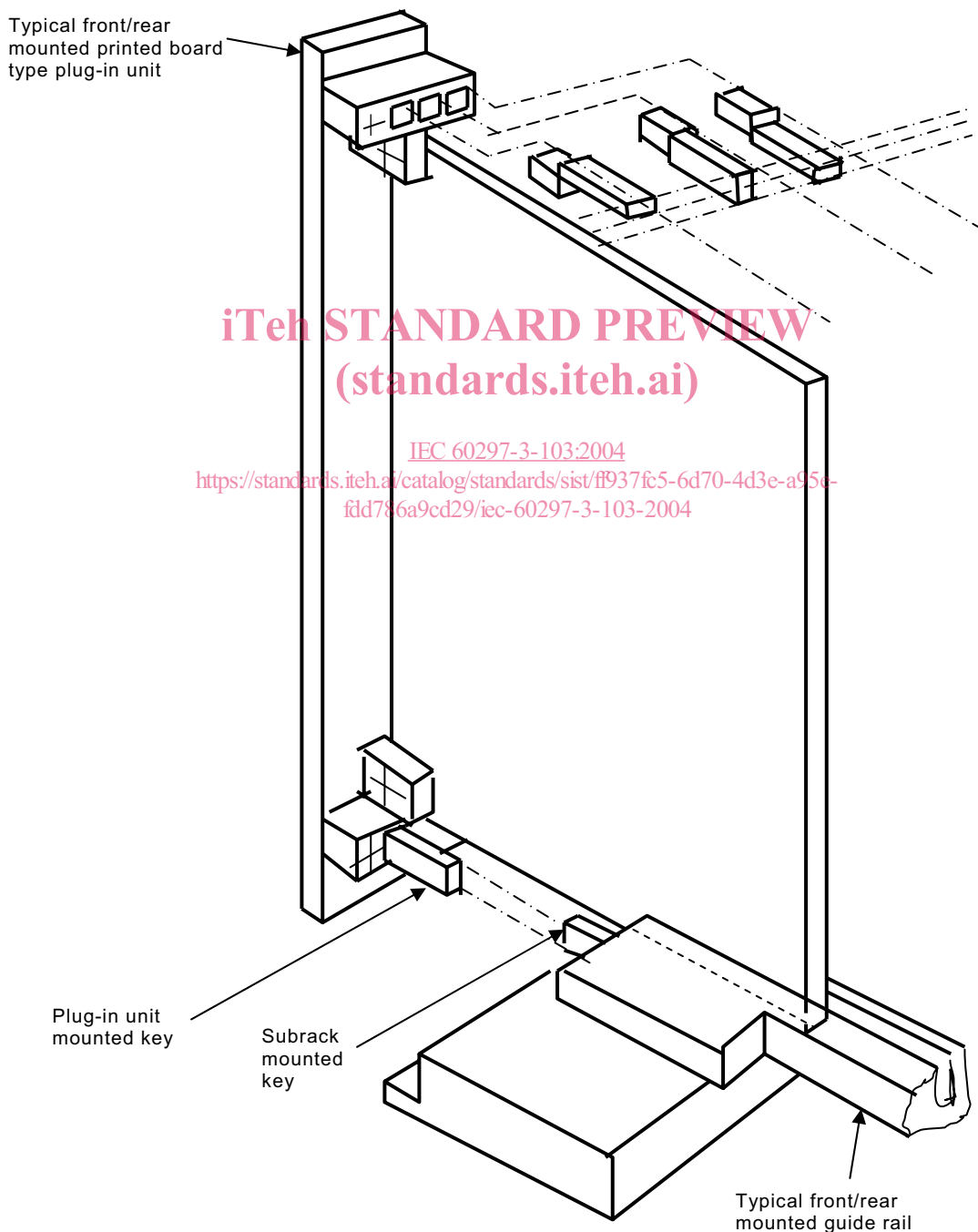

IEC 1112/04

Figure 2 – Keying of a plug-in unit in a subrack

4.2 Subrack interface dimensions for keying

All dimensions are in millimetres

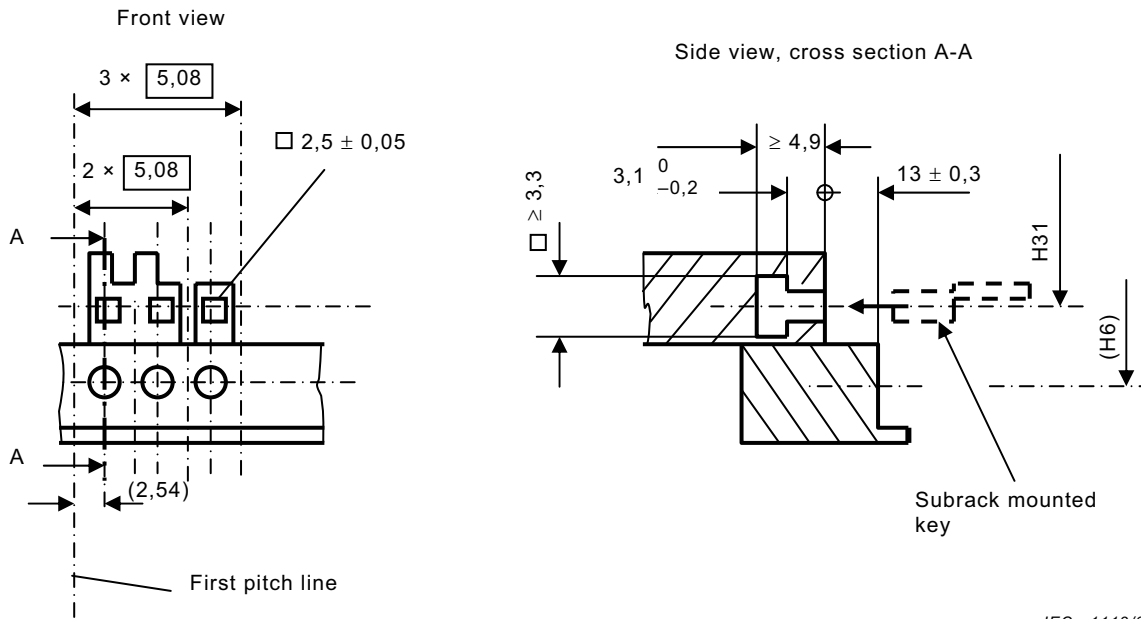

IEC 1113/04

STANDARD PREVIEW

NOTE The two chamber solution may be used for box type plug-in units. The three chamber solution is suitable for printed board type plug-in units. Keying on the rear of the subrack is of mirror image.

For missing dimensions and those in brackets, see IEC 60297-3-101.

Figure 3 – Subrack interface dimensions for keying

<https://standards.iteh.ai/catalog/standards/sist/f937fc5-6d70-4d3e-a95e-fdd786a9cd29/iec-60297-3-103-2004>

4.3 Plug-in unit keying interface dimensions

All dimensions are in millimetres

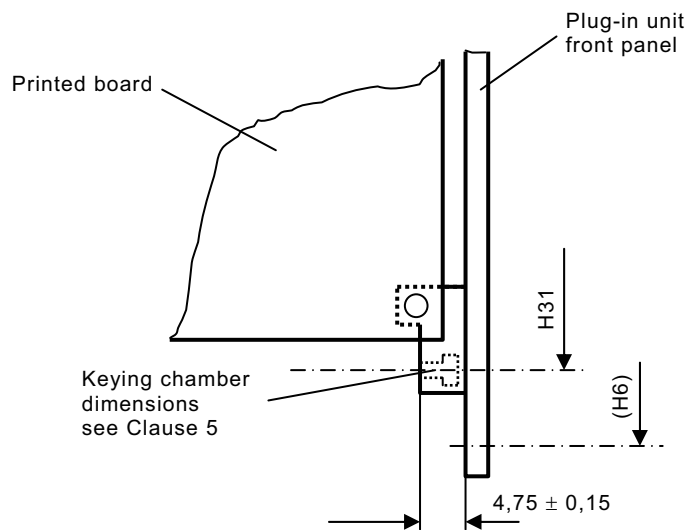

IEC 1114/04

NOTE For missing dimensions, see 4.2.

Figure 4 – Plug-in unit keying interface dimensions

4.4 Key dimensions

The key dimensions will allow the programming of four positions within a subrack mounting chamber. The key shall be designed for a selfretaining snap-in assembly.

The subrack mounting chambers are identified by letters. For a safe function on 3U subracks, the keying is recommended on the lower side only, whereas for 6U and 9U keying in both positions, on the upper and lower side, is necessary.

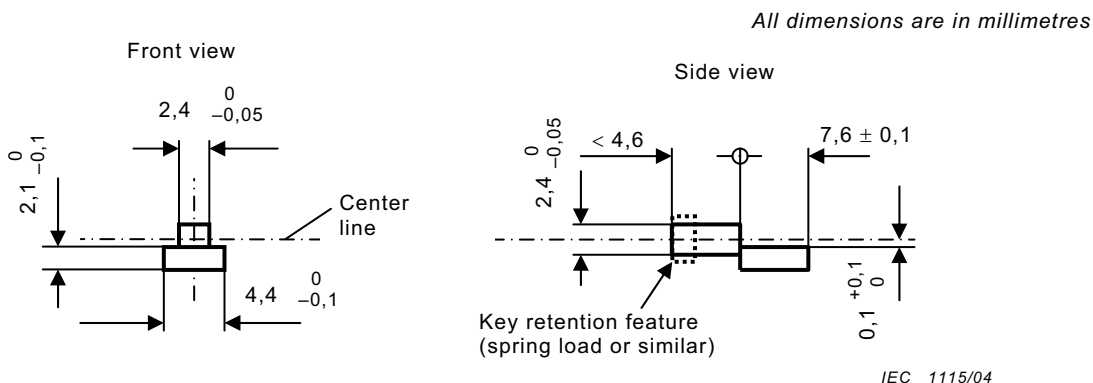
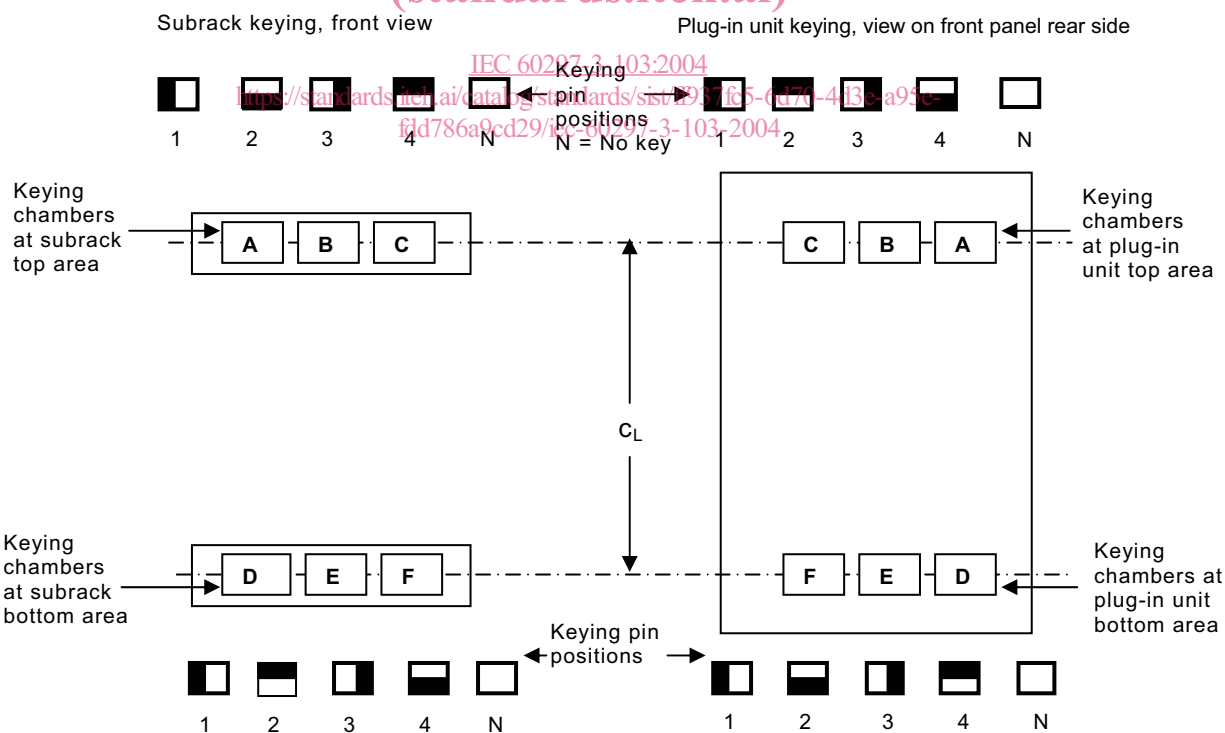

Figure 5 – Key dimensions

4.5 Programming of keys



NOTE The corresponding keying chambers on the subrack and the plug-in unit are indicated by the same letters. The numbering order of keying pins as shown was chosen with the purpose that the corresponding chambers with the same keying pin identification number will not block by inserting a plug-in unit. If corresponding chambers are fitted with different keying identification numbers, the plug-in unit will be blocked and cannot be inserted. On the rear of the subrack/plug-in unit the letters A, B, C will be on the bottom and D, E, F on the top. The order of letters on the rear is of mirror image.

Figure 6 – Programming of keys