



Designation: G195 – 22

Standard Guide for Conducting Wear Tests Using a Rotary Platform Abraser¹

This standard is issued under the fixed designation G195; the number immediately following the designation indicates the year of original adoption or, in the case of revision, the year of last revision. A number in parentheses indicates the year of last reapproval. A superscript epsilon (ϵ) indicates an editorial change since the last revision or reapproval.

1. Scope*

1.1 This guide covers and is intended to assist in establishing procedures for conducting wear tests of rigid or flexible materials utilizing the rotary platform abraser.

1.2 The values stated in SI units are to be regarded as standard. No other units of measurement are included in this standard.

1.2.1 *Exception*—Non-SI units are used when stating rotational speed.

1.3 *This standard does not purport to address all of the safety concerns, if any, associated with its use. It is the responsibility of the user of this standard to establish appropriate safety, health, and environmental practices and determine the applicability of regulatory limitations prior to use.*

1.4 *This international standard was developed in accordance with internationally recognized principles on standardization established in the Decision on Principles for the Development of International Standards, Guides and Recommendations issued by the World Trade Organization Technical Barriers to Trade (TBT) Committee.*

2. Referenced Documents

2.1 *ASTM Standards:*²

- B607 Specification for Autocatalytic Nickel Boron Coatings for Engineering Use
- B733 Specification for Autocatalytic (Electroless) Nickel-Phosphorus Coatings on Metal
- B893 Specification for Hard-Coat Anodizing of Magnesium for Engineering Applications
- C501 Test Method for Relative Resistance to Wear of Unglazed Ceramic Tile by the Taber Abraser
- C744 Specification for Prefaced Concrete and Calcium Silicate Masonry Units
- C957/C957M Specification for High-Solids Content, Cold

- Liquid-Applied Elastomeric Waterproofing Membrane With Integral Wearing Surface
- C1353/C1353M Test Method for Abrasion Resistance of Dimension Stone Subjected to Foot Traffic Using a Rotary Platform Abraser
- C1803 Guide for Abrasion Resistance of Mortar Surfaces Using a Rotary Platform Abraser
- D154 Guide for Testing of Varnishes (Withdrawn 2018)³
- D1044 Test Method for Resistance of Transparent Plastics to Surface Abrasion by the Taber Abraser
- D1475 Test Method for Density of Liquid Coatings, Inks, and Related Products
- D2205 Guide for Selection of Tests for Traffic Paints
- D3389 Test Method for Coated Fabrics Abrasion Resistance (Rotary Platform Abrader)
- D3451 Guide for Testing Coating Powders and Powder Coatings
- D3489 Test Methods for Microcellular Urethane Materials
- D3730 Guide for Testing High-Performance Interior Architectural Wall Coatings
- D3794 Guide for Testing Coil Coatings
- D3884 Guide for Abrasion Resistance of Textile Fabrics (Rotary Platform, Double-Head Method)
- D4060 Test Method for Abrasion Resistance of Organic Coatings by the Taber Abraser
- D4685/D4685M Test Method for Pile Fabric Abrasion
- D4712 Guide for Testing Industrial Water-Reducible Coatings (Withdrawn 2014)³
- D5034 Test Method for Breaking Strength and Elongation of Textile Fabrics (Grab Test)
- D5035 Test Method for Breaking Force and Elongation of Textile Fabrics (Strip Method)
- D5144 Guide for Use of Protective Coating Standards in Nuclear Power Plants
- D5146 Guide to Testing Solvent-Borne Architectural Coatings
- D5324 Guide for Testing Water-Borne Architectural Coatings
- D6037 Test Methods for Dry Abrasion Mar Resistance of High Gloss Coatings
- D7255 Test Method for Abrasion Resistance of Leather

¹ This guide is under the jurisdiction of ASTM Committee G02 on Wear and Erosion and is the direct responsibility of Subcommittee G02.30 on Abrasive Wear. Current edition approved June 1, 2022. Published June 2022. Originally approved in 2008. Last previous edition approved in 2021 as G195 – 21. DOI: 10.1520/G0195-22.

² For referenced ASTM standards, visit the ASTM website, www.astm.org, or contact ASTM Customer Service at service@astm.org. For *Annual Book of ASTM Standards* volume information, refer to the standard's Document Summary page on the ASTM website.

³ The last approved version of this historical standard is referenced on www.astm.org.

*A Summary of Changes section appears at the end of this standard

(Rotary Platform, Abraser Method)

E1795 Specification for Non-Reinforced Liquid Coating Encapsulation Products for Leaded Paint in Buildings

F362/F362M Test Method for Determining the Erasability of Inked Ribbons (Withdrawn 2016)³

F510/F510M Test Method for Resistance to Abrasion of Resilient Floor Coverings Using an Abrader with a Grit Feed Method

F1344 Specification for Rubber Floor Tile

F1478 Test Method for Determination of Abrasion Resistance of Images Produced from Copiers and Printers (Taber Method) (Withdrawn 2020)³

F1978 Test Method for Measuring Abrasion Resistance of Metallic Thermal Spray Coatings by Using the Taber Abraser

F2051 Specification for Implantable Saline Filled Breast Prosthesis

F2068 Specification for Femoral Prostheses—Metallic Implants

G40 Terminology Relating to Wear and Erosion

3. Terminology

3.1 *Definitions of Terms Specific to This Standard:*

3.1.1 *abraser*, *n*—wear testing instrument to evaluate abrasion resistance, also referred to as an abrader.

3.1.2 *abrasion cycle*, *n*—in abrasion testing, one or more movements of the abrasant across a material surface, or the material surface across the abrasant, that permits a return to its starting position. In the case of the rotary platform abraser test method, it consists of one complete rotation of the turntable specimen platform.

3.1.3 *resurface*, *v*—procedure of cleaning and refreshing the running surface of an abrasive wheel prior to use or during testing.

3.2 For definitions of other wear terms used in this guide, refer to Terminology **G40**.

3.3 *Acronyms:*

3.3.1 *CAMI*—Coated Abrasives Manufacturers Institute

4. Summary of Guide

4.1 A specimen is abraded using rotary rubbing action under controlled conditions of pressure and abrasive action. The test specimen, mounted on a turntable platform, turns on a vertical axis, against the sliding rotation of two abrading wheels. The wheels shall be mounted in such a way that when they are in contact with the rotating test specimen, they rotate in opposing directions. One abrading wheel rubs the specimen outward toward the periphery and the other, inward toward the center while a vacuum system removes wear debris generated during the test. The resulting abrasion marks form a pattern of crossed arcs over an area of approximately 30 cm². Resistance to abrasion is evaluated by various means which are described in Section **12**.

5. Significance and Use

5.1 This test guide provides a means to quantify the abrasion resistance of material surfaces, and may be related to

end-use performance, or used to comparatively rank material performance, or both. The resistance of material surfaces to abrasion, as measured on a testing machine in the laboratory, is generally only one of several factors contributing to wear performance as experienced in the actual use of the material. Other factors may need to be considered in any calculation of predicted life from specific abrasion data.

5.2 The resistance of material surfaces to abrasion may be affected by factors including test conditions; type of abrasant; pressure between the specimen and abrasant; mounting or tension of the specimen; and type, kind, or amount of finishing materials.

5.3 Abrasion tests utilizing the rotary platform abraser may be subject to variation due to changes in the abrasant during the course of specific tests. Depending on abrasant type and test specimen, the abrading wheel surface may change (that is, become clogged) due to the pick-up of finishing or other materials from test specimens. To reduce this variation, the abrading wheels should be resurfaced at regularly defined intervals. See **Appendix X2**.

5.4 When evaluating resistance to abrasion of two or more coatings, other factors may need to be considered for an accurate comparison. Flexible coatings that include air entrainment bubbles may result in less mass loss. Coatings that include fillers may result in greater mass loss but have less change in coating thickness or less mass loss but have greater change in coating thickness. Coatings that include aggregates or particulates may generate wear debris that is not removed by the vacuum and contribute to the break-down of the coating. Coatings that have a hardness value greater than the abrasive wheel may cause the abrasive wheel to break down faster and require more wear cycles to generate measurable wear. Examples of coatings that may be impacted include epoxies, polymethyl-methacrylate (PMMA), polyurethane-methacrylate (PUMA), methyl-methacrylate (MMA), and carbon resin.

NOTE 1—As an example, consider a urethane coating of 0.5 mm thickness, embedded with 1.2 μm titanium particles that resulted in a 53 μm loss in coating thickness and 110 mg mass loss. A similar urethane coating without titanium particles resulted in a 78 μm loss in coating thickness and 44 mg mass loss.

5.5 The measurement of the relative amount of abrasion may be affected by the method of evaluation and influenced by the judgment of the operator.

6. Apparatus

6.1 *Rotary Platform Abraser*, consisting of the elements described in **6.1.1** to **6.1.5** (see **Fig. 1**). Also referred to as a rotary platform, double head (RPDH) abraser or abrader.

6.1.1 A turntable specimen platform, which is removable, that includes a rubber pad, clamp plate, centrally located threaded post and nut. When testing flexible specimens, the turntable platform will also include a clamping ring. The turntable shall be motor driven, and mounted so as to produce a circular surface travel of a flat specimen in the plane of its surface. The turntable platform should rotate with no visible wobble. This can be checked with a dial indicator at a distance of 1.6 mm from the top outer edge of the platform to make sure it runs true within 0.2 mm.

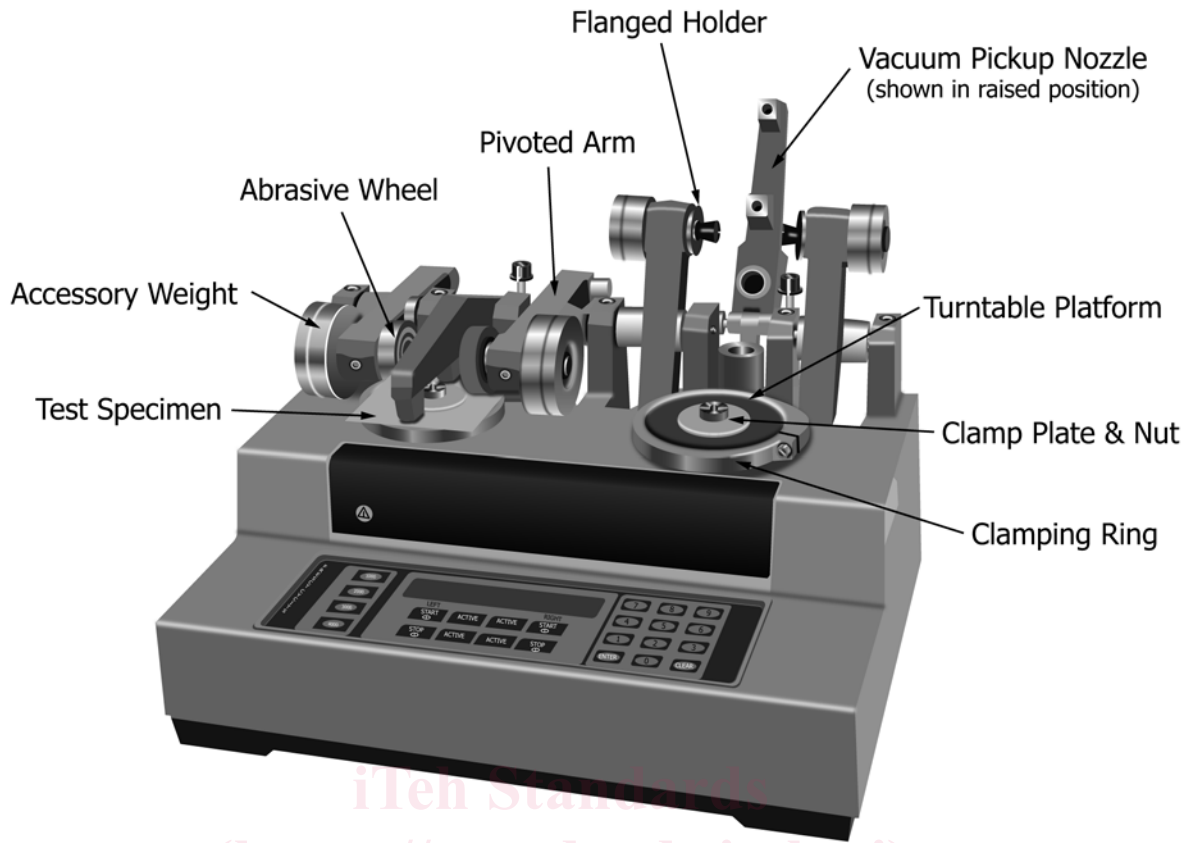

Note: Vacuum Suction System not shown

FIG. 1 Rotary Platform Abraser

6.1.2 A motor capable of rotating the turntable platform counter-clockwise at a speed of either $72 \text{ r/min} \pm 2 \text{ r/min}$ or $60 \text{ r/min} \pm 2 \text{ r/min}$.

6.1.3 A pair of pivoted arms to which the abrasive wheels and accessory weights or counterweights are attached.

6.1.4 A vacuum suction system and vacuum pickup nozzle to remove debris and abrasive particles from the specimen surface during testing. The vacuum suction force shall be 13.7 kPa or greater, as measured by a vacuum gauge at the vacuum pick-up nozzle port. The height of the vacuum pickup nozzle shall be adjustable, and the nozzle will have two 8 mm openings except in the case of Test Method **D1044** when 11 mm openings are specified. One opening shall be positioned between the two wheels and over the wear path and the other placed diametrically opposite, with the distance between the axes of the two openings $76.0 \text{ mm} \pm 1.0 \text{ mm}$.

6.1.5 A counter to record the number of abrasion cycles (revolutions) made by the turntable platform.

6.2 *Abrasive Wheels*,⁴ which are attached to the free end of the pivoted arms and are able to rotate freely about horizontal spindles.

⁴ The sole source of supply of the apparatus known to the committee at this time is Taber Industries, 455 Bryant Street, North Tonawanda, NY 14120. If you are aware of alternative suppliers, please provide this information to ASTM International Headquarters. Your comments will receive careful consideration at a meeting of the responsible technical committee,¹ which you may attend.

6.2.1 The wheels shall be cylindrically shaped; $12.7 \text{ mm} \pm 0.3 \text{ mm}$ thick; include an axial hole $16.0 \text{ mm} \pm 0.1 \text{ mm}$ to allow the wheel to be mounted to the flanged holder on the pivoted arm; and have an external diameter of $51.9 \text{ mm} \pm 0.5 \text{ mm}$ when new, and in no case less than 44.4 mm . The abrasive wheels are either resilient or vitrified based, with both types of wheels consisting of hard particles embedded in a binder material and manufactured in different grades of abrasive quality. Other types of wheels, which do not include hard particles embedded in a binder material, may also be used (see **X1.4**).

6.2.2 The internal faces of the abrasive wheels shall be $52.4 \text{ mm} \pm 1.0 \text{ mm}$ apart and the hypothetical line through the two spindles shall be $19.05 \text{ mm} \pm 0.3 \text{ mm}$ away from the central axis of the turntable (see **Fig. 2**). The wheels shall be spaced equally on both sides from the wheel-mounting flange to the center of the specimen holder. The distance from the inside of the wheel mounting flange to the center of the specimen holder shall be $38.9 \text{ mm} \pm 0.5 \text{ mm}$.

6.2.3 When resting on the specimen, the wheels will have a peripheral engagement with the surface of the specimen, the direction of travel of the periphery of the wheels and of the specimen at the contacting portions being at acute angles, and the angles of travel of one wheel periphery being opposite to that of the other. Motion of the abrasive wheels, in opposite directions, is provided by rotation of the specimen and the associated friction therefrom.

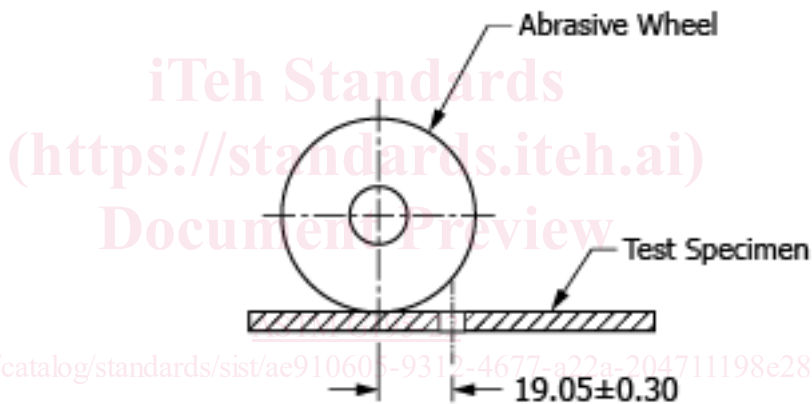
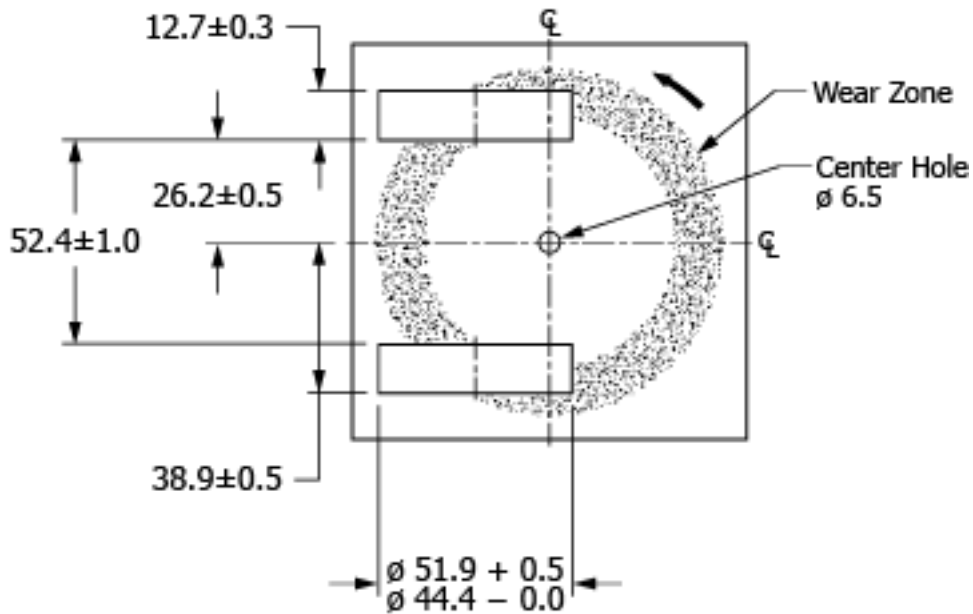

dimensions in millimeters

FIG. 2 Arrangement of Rotary Platform Abraser Test Set-Up

6.2.4 Wheels with an expiration date shall not be used after the date stamped on them.

6.3 *Accessory Weights*, can be attached to the pivoted arms to increase or decrease the force at which the wheel is pressed against the specimen, exclusive of the mass of the wheel itself. Commonly used masses are $250\text{ g} \pm 1\text{ g}$, $500\text{ g} \pm 1\text{ g}$, and $1000\text{ g} \pm 1\text{ g}$. Accessory weight references are per arm (not combined), and include the mass of the pivoted arm.

6.4 *Auxiliary Apparatus:*

6.4.1 Refacing disc, for resurfacing of resilient wheels. The refacing disc shall be silicon carbide coated abrasive with an average particle size of $92\text{ }\mu\text{m}$ (150 grit CAMI grade), approximately 102 mm diameter with a 7 mm center hole, such as type S-11 or equivalent.

6.4.2 Refacing stone (for example, fine side of ST-11⁴), for resurfacing of CS-10F⁴ resilient wheels when testing transparent materials.

6.4.3 Wheel refacer, with a diamond tool for resurfacing vitrified wheels or correcting out of round wheels.

6.4.4 A soft bristle brush, to remove loose particles from the surface of the specimen after testing.

6.4.5 Specimen mounting cards, approximately 108 mm round or square with a 7 mm center hole and one side coated with pressure sensitive adhesive to secure specimens.

7. Specimen Preparation

7.1 *Materials*—It is the intent of this test guide to allow for the abrasion testing of any material form, provided it is essentially flat. The field of application is varied and includes solid materials, metals, plastics, coated surfaces (for example, paint, lacquer, electroplated), textiles (ranging from sheer silks to heavy upholstery), leather, rubber, linoleum, and the rest.

7.1.1 Accepted industry practice should be employed for specimen preparation. Specific recommendations for specimen

preparation may be available from the ASTM subcommittee responsible for that material. Selection and use should be agreed upon between the interested parties.

7.2 Specimen Thickness—The standard material thickness that can be evaluated with the rotary platform abraser is 6.5 mm or less.

NOTE 2—For materials thicker than 6.5 mm but less than 12.7 mm, an extension nut such as type S-21⁴ or equivalent may be used. Alternatively, an arm height extension kit⁴ will permit testing of specimens up to 40 mm.

7.3 Specimen Size—The width of the resulting wear path is 12.7 mm, and is located 31.75 mm from the center of the specimen. The size of the specimen may vary depending on the material being evaluated:

7.3.1 For most rigid materials, a sample approximately 100 mm square is recommended with a 6.5 mm diameter center hole.

7.3.2 Flexible specimens are typically circular and require the use of the clamp ring. If a mounting card is used, the specimen should be approximately 105 mm in diameter with a 6.5 mm diameter center hole. If no mounting card is used, an approximately 135 mm specimen is required such that the clamp ring will grip overlapped material. The specimen should include a 6.5 mm diameter hole in the center of the specimen. A sample cutter or die has been found useful for preparing flexible specimens.

7.4 Mounting Card—Certain flexible specimens may wrinkle or shift during testing. To prevent this, a mounting card with a pressure sensitive adhesive may be used. Prior to adhering, clean the back of the specimen with a soft bristle brush to remove any loose debris. Position the specimen on the card such that the specimen is free of folds, creases, or wrinkles and the center holes align.

8. Preparation and Set-Up of Apparatus

8.1 The following set-up parameters are dependent on the type of material being evaluated and shall be agreed upon by the interested parties. See [Appendix X1](#) for guidance.

8.1.1 Selection of Wheels—Abrasive wheels manufactured in different grades are commercially available.⁴

8.1.2 Vacuum Suction—The vacuum suction force should be adjusted to lift the abraded particles, but not lift the specimen.

8.1.3 Vacuum Pickup Nozzle—The gap between the vacuum pickup nozzle and the specimen surface should be adjusted after the specimen has been mounted. A gap of 7 mm ± 1 mm has been found to be sufficient for most materials. On certain rigid materials, a setting of 3 mm ± 1 mm has been found to be more effective.

8.1.4 Abrading Wheel Loading—The mass selected should permit a minimum number of abrasion cycles (for example, 150) before the end of the test occurs. A mass of 500 g or 1000 g applied per wheel has been found to be sufficient for materials that are considered to be durable. A mass of 250 g or 500 g applied per wheel has been found to be sufficient for less durable materials.

9. Standardization of Abrasive Wheels

9.1 Preparation of Resilient Abrading Wheels—To ensure that the abrading function of the wheels is maintained at a

constant level, prepare the resilient wheels according to the manufacturer's recommendations. See [Appendix X2](#).

9.2 Preparation of Vitrified Abrading Wheels—Vitrified wheels do not require resurfacing unless the abrading surface becomes clogged, chipped, or out of round. A wheel refacer should be used to correct any of these conditions.

10. Conditioning

10.1 Prior to testing, condition all specimens according to established procedures specific to the material being evaluated or as agreed upon by the interested parties.

11. Procedure

11.1 Mount the wheels on their respective flanged holders, taking care not to handle them by their abrasive surfaces. Prior to testing, ensure that the wheels have been resurfaced according to [Section 9](#) if necessary.

11.2 Depending on the type of evaluation criteria being utilized (see [Section 12](#)), it may be necessary to measure and record specific parameters of the unabraded specimen prior to conducting the test:

11.2.1 Mass loss method, weigh the specimen to the nearest mg. If using a mounting card, weigh after the specimen has been affixed to the card and conditioned in the standard testing environment.

11.2.1.1 When comparing the wear resistance of materials that have different specific gravities, a correction for the specific gravity of each coating must be applied to the mass loss to give a true measure of the comparative wear resistance. Calculate the mass loss as shown in [12.2](#) or wear index as shown in [12.3](#), then divide the result by the material's specific gravity as determined by Test Method [D1475](#). The use of this correction factor provides a mass loss or wear index relative to the loss in volume of the material to which it is applied. When comparing materials of different specific gravities, the test parameters shall be the same.

11.2.2 Wear cycles per μm (or mm) or depth of wear method, use a thickness gauge or other appropriate device to measure the specimen thickness on four points along the path to be abraded, approximately 38 mm from the center hole and 90° apart. Calculate the average of the readings.

11.3 Mounting of Specimen—Place the test specimen face up over the rubber mat on the turntable platform, unless otherwise specified. If the turntable platform was previously removed, ensure it is properly replaced on the motor drive shaft of the abraser prior to testing.

11.3.1 For rigid materials, secure the clamp plate and nut in place to hold the specimen.

11.3.2 For textile and other flexible materials, lightly secure the clamp plate and nut in place to hold the center of the specimen. Place the clamping ring over the turntable platform with the screw of the clamping ring at one end of the warp. Partially tighten the screw, and push the clamping ring half way down the edge of the turntable platform. Draw the specimen taut over the turntable platform by pulling on the corners and edges of the specimen. Tighten the clamping ring ¼ turn and push the ring all the way down, thus putting tension on the specimen as it is secured on turntable platform. Finish

tightening the nut and clamping ring. Avoid buckling the fabric when tightening. Trim off excess fabric around the edges. It is recommended not to remove the specimen from the turntable platform until the entire test is completed.

11.4 *Abrading Wheel Loading*—Select the mass to be used and affix it to the rotary platform abramer (see 8.1.4).

11.5 *Number of Abrasion Cycles*—The number of rotations of the turntable platform to which the specimen is to be subjected will depend on the type of material being tested, the type of abrading wheels used, the abrading wheel loading, and the type of test employed. The number of cycles should be predetermined by mutual agreement by the interested parties, except when the number of cycles required to reach a predetermined end point is not known.

11.6 Lower the abrading heads carefully onto the surface of the specimen.

11.7 *Cleaning of Specimen*—The vacuum system is used to clean the specimen of debris and abrasive particles during the test. Position the nozzle above the specimen surface as determined in 8.1.3 and adjust the vacuum suction as outlined in 8.1.2. For some materials, it may be necessary to use a soft bristle brush to clean the specimen surface at set intervals during the test.

11.8 Start the rotary platform abramer and subject the test specimen to abrasion for the specified number of cycles as established in 11.5.

11.8.1 Depending on the type of evaluation criteria being utilized (see Section 12), the rate of wear may be calculated or plotted on a graph, or both. If required, take measurements periodically during testing with the frequency to be determined by the interested parties.

NOTE 3—When calculating Wear Index (see 12.3) or Wear Cycles per μm (or mm) (see 12.4) of surface coatings and similar materials, it may be advisable to discard the final reading if results are affected by abrasion of the exposed substrate.

11.8.2 If cycles to a specific end point is used as the evaluation criteria (see 12.7), it may be necessary to stop the instrument at intervals during the test to examine the test specimen.

11.9 *Resurfacing of Wheels*—Due to uneven wear and clogging of the surface crevices with abraded debris (for example, fiber particles, finishing materials, and the like), the abrading wheels should be resurfaced at established intervals during tests, the frequency depending on the type of material being tested and the type of wheel used (see Appendix X2).

11.10 *Cleaning of Specimen After Test*—After the test is complete, a soft bristle brush may be used to remove any loose debris and abraded material remaining on the test specimen.

11.11 After testing, raise the abrader arms and vacuum nozzle then remove the specimen for evaluation. If desired, the turntable platform may be removed from the abramer by lifting straight up. This will permit a closer inspection of the specimen prior to removal from the turntable platform. Use a soft bristle brush or cloth to clean the rubber pad after each test.

11.12 Using the same conditions and materials, perform a minimum of three replicate tests unless otherwise agreed upon by the interested parties.

12. Calculation or Interpretation of Results

NOTE 4—This guide does not recommend any specific interpretation of results but does provide procedures commonly used by industry.

12.1 After the specimens have been abraded to the set number of cycles or other specified endpoint, evaluate as directed in 12.2 – 12.10 as appropriate. If a mounting card was used and any evaluation technique described in 12.8 – 12.10 is employed, carefully remove the specimen from the mounting card.

12.2 *Mass Loss*—Change in mass caused by abrasion. Weigh the specimen after abrasion and compute mass loss, L , of the test specimen as follows:

$$L = A - B \quad (1)$$

where:

A = mass of test specimen before abrasion, mg, and
 B = mass of test specimen after abrasion, mg.

12.3 *Wear Index*—Loss in mass in milligrams per thousand cycles of abrasion. Weigh the specimen after abrasion and compute the wear index, I , of a test specimen as follows:

$$I = \frac{(A - B) 1000}{C} \quad (2)$$

where:

A = mass of test specimen before abrasion, mg,
 B = mass of test specimen after abrasion, mg, and
 C = number of cycles of abrasion recorded.

12.4 *Wear Cycles per μm (or mm)*—Abrasion cycles required to wear through a coating of a known thickness. Compute the wear cycles per μm (or mm), W , of the test specimen as follows:

$$W = \frac{D}{T} \quad (3)$$

where:

D = number of cycles of abrasion required to wear coating through to substrate, and
 T = thickness of coating, μm (or mm).

12.5 *Volume Loss*—In comparing the wear resistance of materials having different specific gravities, a correction for the specific gravity of each material should be applied to the mass loss to give a true measure of the comparative wear resistance. Calculate the wear index as shown in 12.3 and divide the result by the material's specific gravity. The use of this correction factor provides a wear index related to the loss in volume of the material to which it is applied. When comparing materials of different specific gravities, test parameters shall be the same including wheel selection and abrading wheel loading.

12.6 *Depth of Wear Method (Thickness)*—Repeat the thickness measurements taken in 11.2.2 at the same four points. Calculate the average of the four readings, then calculate the difference between the average thickness before and after abrasion. Alternatively, an instrument such as an optical micrometer may be used to measure the depth of wear.

12.7 *Cycles to a Specific End-Point*—The number of cycles required to reach a predetermined end point, or the appearance or condition of the specimen after a fixed number of cycles. The evaluation criteria may include: loss in breaking strength, yarn breakage, loss in coating, change in gloss, color loss, or other changes in appearance. In these cases, the abraded sample is usually compared to a known standard of the material tested. Aesthetic evaluations can be made using an agreed upon rating system such as a visual grading scale (for example, five-step) or pass/fail criteria.

12.8 *Residual Breaking Force*—The effective strength of the fabric or force required to break a specific width of fabric. If residual breaking force is required, calculate the individual breaking force of the individual abraded specimens and the unabraded specimens to the nearest 0.5 kg significant digits. Use Test Method **D5034** and **D5035**, as appropriate, except that the distance between clamps shall be 25 mm and path of the abrasion on the abraded specimen is horizontally placed midway between the clamps of the machine.

12.9 *Average Breaking Strength*—If average breaking strength is required, calculate the average breaking strength of the abraded specimens and the unabraded specimens separately to the nearest 0.5 kg for the laboratory sampling unit and for the lot using the procedure described in **12.8**.

12.10 *Percent Loss in Breaking Strength*—If percent breaking strength is required, calculate the percentage loss in breaking strength to the nearest 1 % of the abrasion resistance separately for each the lengthwise and widthwise directions using **Eq 4**, for the laboratory sampling unit and for the lot.

$$AR = \frac{100(A - B)}{A} \quad (4)$$

where:

- AR* = abrasion resistance, %,
A = average breaking force of the unabraded specimens, g,
 and
B = average breaking force of the abraded specimen, g.

13. Report

13.1 State that the specimens were tested as directed in Guide G195. Describe the product and the method used for sample collection.

13.2 Report the following information:

13.2.1 Temperature and humidity during conditioning and at time of testing.

13.2.2 Type of wheel used and manufacturing lot number.

13.2.3 Abrading wheel loading.

13.2.4 Vacuum suction level.

13.2.5 Height of vacuum pickup nozzle above specimen surface.

13.2.6 Specimen mounting card (only when used).

13.2.7 Evaluation criteria used to obtain failure or other end point, and results as determined in Section **12**. If any other means of evaluating the effect of abrasion are used, describe evaluation criteria used to obtain failure or other end point.

13.3 Any deviation from the procedure described in this guide.

14. Keywords

14.1 abraser; abrasion; abrasion resistance; rotary platform; Taber; wear

ASTM G195-22

<https://standards.iteh.ai/catalog/standards/sist/ae94677-a22a-204711198e28/astm-g195-22>

APPENDIXES

(Nonmandatory Information)

X1. ABRADING WHEEL AND LOAD SELECTION

X1.1 Material specifications and test methods have been developed for many different types of materials by ASTM and other standards organizations. If you are following a particular material specification, please refer to it for the appropriate wheel and load combination or follow industry accepted guidelines.

X1.2 The following information is intended to serve as a guideline only, when testing parameters are not specified. Deciding which abrading wheel and load combination is appropriate for your application is best determined with preliminary testing on the actual material. The ideal outcome using this selection criterion is to reproduce the resulting wear that occurs in actual use. A correction factor may be necessary if there is no absolute fit between lab test results and field results. It is important to recognize that abrasive wheels

represent a limited subset of actual contact conditions that material surfaces will be subjected to while in service.

X1.3 The following standardized abrasive wheels are commercially available:⁴

X1.3.1 *Resilient Wheels* (see **6.4.1**):

CS-8	Mild abrasive action
CS-10F	Light abrasive action (see 6.4.2 and Note X2.1)
CS-10	Medium abrasive action
CS-17	Medium to coarse abrasive action

X1.3.2 *Vitrified (Clay) Wheels* (see **6.4.3**):

H-38	Light abrasive action (requires multi-point diamond tool for refacing)
H-10	Light to medium abrasive action
H-18	Medium abrasive action
H-22	Coarse abrasive action